

IBM Storwize V7000 Unified  
Version 1.3  
Machine Types 2073-700 and 2076

## *Quick Installation Guide*



**Note**

Before using this information and the product it supports, read the general information in “Notices” on page 69, the information in the “Safety and environmental notices” on page ix, as well as the information in the *IBM Environmental Notices and User Guide* , which is provided on a DVD.

This edition applies to the IBM Storwize V7000 Unified, Version 1.3, and to all subsequent releases and modifications until otherwise indicated in new editions.

© Copyright IBM Corporation 2011, 2012.

US Government Users Restricted Rights – Use, duplication or disclosure restricted by GSA ADP Schedule Contract with IBM Corp.

---

# Contents

**Figures . . . . . v**

**Tables . . . . . vii**

**Safety and environmental notices . . . ix**

Sound pressure . . . . . ix

**Chapter 1. Before you begin the installation . . . . . 1**

Step 1. Reviewing your packing slip . . . . . 2

Step 2. Identifying the hardware components . . . . 4

Step 3. Verifying environmental requirements . . . . 8

Step 4. Reviewing enclosure location guidelines . . . 9

**Chapter 2. Performing the hardware installation . . . . . 13**

Step 5. Installing the support rails for control enclosure . . . . . 13

Step 6. Installing the enclosures. . . . . 16

Step 7. Installing the support rails for file module slides . . . . . 18

Step 8. Installing the file modules . . . . . 22

Step 9. Connecting the SAS cables to the expansion enclosures . . . . . 26

Step 10. Attaching the Ethernet cables . . . . . 31

Step 11. Attaching the Fibre Channel cables. . . . 36

Step 12. Connecting the power cords . . . . . 37

Step 13. Powering the system on and off . . . . . 39

**Chapter 3. Configuring the system. . . . 45**

Initialize the Storwize V7000. . . . . 45

Initialize the file modules. . . . . 48

Configure the software . . . . . 49

Change default passwords . . . . . 62

Check the Storwize V7000 Unified system status . . 62

Upgrade the Storwize V7000 Unified software. . . 62

Problems with initial configuration . . . . . 62

Enable IBM Tivoli Assist On-Site (AOS) . . . . . 64

**Appendix. Accessibility . . . . . 67**

**Notices . . . . . 69**

Trademarks . . . . . 71

Electronic emission notices . . . . . 71

Federal Communications Commission (FCC)

statement . . . . . 71

Industry Canada compliance statement . . . . 72

Avis de conformité à la réglementation

d'Industrie Canada . . . . . 72

Australia and New Zealand Class A Statement . . 72

European Union Electromagnetic Compatibility

Directive . . . . . 72

Germany Electromagnetic compatibility directive . 73

Japan VCCI Council Class A statement . . . . . 74

People's Republic of China Class A Electronic

Emission Statement. . . . . 74

International Electrotechnical Commission (IEC)

statement . . . . . 74

United Kingdom telecommunications

requirements . . . . . 74

Korean Communications Commission (KCC)

Class A Statement . . . . . 74

Russia Electromagnetic Interference (EMI) Class

A Statement . . . . . 75

Taiwan Class A compliance statement . . . . . 75

European Contact Information . . . . . 75

Taiwan Contact Information . . . . . 75



## Figures

1.	This figure shows 12 drives and two end caps (model 2076-112). . . . .	4	26.	Install the cable management arm. . . . .	24
2.	This figure shows 24 drives and two end caps (model 2076-124). . . . .	4	27.	Adjust the location of the cable management arm. . . . .	25
3.	Rear view of a model 2076-112 or a model 2076-124 control enclosure . . . . .	4	28.	Connect and route the cables. . . . .	25
4.	This figure shows the data ports in the rear of the control enclosure.. . . .	5	29.	Secure the cable management arm and the file module in the rack for shipping if needed. . . . .	26
5.	10 Gbps Ethernet ports on the rear of the Storwize V7000 enclosure . . . . .	6	30.	Install the front screws. . . . .	26
6.	Rear view of a model 2076-212 or a model 2076-224 expansion enclosure . . . . .	6	31.	Internal cabling connections between file modules ([A] & [B]), control enclosure ([C]), and expansion enclosures ([D] & [E]). . . . .	28
7.	SAS ports and LEDs in rear of expansion enclosure. . . . .	7	32.	Attaching an expansion enclosure to the control enclosure. . . . .	29
8.	Front view of file module . . . . .	8	33.	Adding a second expansion enclosure. . . . .	30
9.	Rear view of file module . . . . .	8	34.	Attaching SAS cables to the enclosures . . . . .	31
10.	Recommended rack locations. . . . .	11	35.	Control enclosure Ethernet network connections. . . . .	32
11.	Securing an enclosure to a rack cabinet . . . . .	14	36.	10 Gbps Ethernet ports on the rear of the Storwize V7000 enclosure . . . . .	33
12.	Hole locations in the front of the rack. . . . .	15	37.	File module node Ethernet network connections. . . . .	34
13.	Hole locations in the back of the rack. . . . .	16	38.	Diagram showing how to connect the file modules to the control enclosure using Fibre Channel cables. Refer to previous table. . . . .	37
14.	Removing the enclosure end cap . . . . .	17	39.	Unlocking the cable retention bracket . . . . .	38
15.	Securing an enclosure to a rack cabinet . . . . .	18	40.	Sliding the cable retention bracket directly behind the power cord. . . . .	39
16.	Cable management arm box contents. . . . .	19	41.	24 drives and two end caps . . . . .	40
17.	Friction rail box contents. . . . .	20	42.	12 drives and two end caps . . . . .	40
18.	Locate a 2U space in the lower section of the rack. . . . .	20	43.	LEDs on the power supply units of the expansion enclosure. . . . .	41
19.	Open the rear slide rail hooks. . . . .	21	44.	LEDs on the power supply units of the control enclosure . . . . .	42
20.	Install the rear end of the slide rails. . . . .	21	45.	Initialization tool welcome panel . . . . .	47
21.	Install the front end of the slide rails. . . . .	22			
22.	Install the front end of the slide rails. . . . .	22			
23.	Install the file module on the slide rails. . . . .	23			
24.	Slide the file module into the rack. . . . .	23			
25.	Install the cable management support arm. It can be installed on either side (left or right). The graphic shows the rear of the rack. . . . .	24			



---

## Tables

1.	Use this table to identify the file module, control enclosure, and expansion unit port locations for Figure 31 on page 28. Follow the links to identify detailed port locations. . . . .	27
2.	How to connect SAS cables to expansion units. Refer to Figure 31 on page 28. . . . .	28
3.	Ethernet connections available with the control enclosure . . . . .	33
4.	Ethernet connections available with the file modules . . . . .	34
5.	How to connect Fibre Channel cables from file modules to the control enclosure. Refer to the graphic below. . . . .	36
6.	LED status front of control enclosure or expansion enclosure. Refers to item [1] in the figures above.. . . .	40
7.	LED status rear of expansion enclosure.	41
8.	LED status when control enclosure is powered on. . . . .	42
9.	The following Information is required before configuring your system. Fill in all the information needed in the Value column before proceeding with this installation. . . . .	45
10.	Create two files and enter one line each, adjusted to the values fitting to your environment. Refer to Table 9 on page 45 for the command content to the appropriate addresses. . . . .	48
11.	This table (optional) is useful for completing the Easy Setup wizard. The table entries serve as a guide only. Enter the Value column with your system information. . . . .	49
12.	Remote support information . . . . .	52
13.	All the information in this table is required.	52
14.	CIDR subnet mask information . . . . .	53
15.	Authentication method information . . . . .	54
16.	<b>Active Directory Configuration Information</b>	54
17.	<b>LDAP CONFIGURATION INFORMATION</b>	56
18.	<b>NIS configuration information</b> . . . . .	57





---

## Safety and environmental notices

Review the multilingual safety notices for the IBM® Storwize® V7000 system before you install and use the product.

**Suitability for telecommunication environment:** This product is not intended to connect directly or indirectly by any means whatsoever to interfaces of public telecommunications networks.

To find the translated text for a caution or danger notice:

1. Look for the identification number at the end of each caution notice or each danger notice. In the following examples, the numbers (C001) and (D002) are the identification numbers.

**CAUTION:**

**A caution notice indicates the presence of a hazard that has the potential of causing moderate or minor personal injury. (C001)**

**DANGER**

<p><b>A danger notice indicates the presence of a hazard that has the potential of causing death or serious personal injury. (D002)</b></p>
---

2. Locate *IBM Systems Safety Notices* with the user publications that were provided with the Storwize V7000 Unified hardware.
3. Find the matching identification number in the *IBM Systems Safety Notices*. Then review the topics concerning the safety notices to ensure that you are in compliance.
4. Optionally, read the multilingual safety instructions on the Storwize V7000 Unified website. Go to the Support for Storwize V7000 Unified website at [www.ibm.com/storage/support/storwize/v7000/unified](http://www.ibm.com/storage/support/storwize/v7000/unified) and click the documentation link.

---

## Sound pressure

**Attention:** Depending on local conditions, the sound pressure can exceed 85 dB(A) during service operations. In such cases, wear appropriate hearing protection.



---

## Chapter 1. Before you begin the installation

The *Quick Installation Guide* contains a set of instructions to help you unpack and install your system. The guide is divided into three chapters. The steps in the first chapter involve verifying your order, becoming familiar with the hardware component terminology, and ensuring that you have met the environmental requirements. The steps in the second chapter involve installing the hardware and attaching the data cables and power cords. The final chapter helps you configure the file modules and control enclosures. It ends with enabling the Tivoli Assist On-site support program.

Occasionally you are referred to topics in the Storwize V7000 Unified Information Center. A copy of the Storwize V7000 Unified Information Center is on the CD that is included in your shipping order.

Important information:

1. The guide assumes that you have read the planning information regarding your physical environment that is available from the Storwize V7000 Unified Information Center.
2. Ensure that you have available any cables that you are supplying.

### IBM Storwize V7000 Unified Information Center

The most current information for Storwize V7000 Unified is available in the *IBM Storwize V7000 Unified Information Center* at [publib.boulder.ibm.com/infocenter/storwize/unified\\_ic/index.jsp](http://publib.boulder.ibm.com/infocenter/storwize/unified_ic/index.jsp). If you are unable to access the internet, there is a copy of the information center on the software CD that was shipped with the product, it contains the environmental notices, the publication PDFs, and the information center content. Insert the CD into a Windows based system, it automatically starts.

### This documentation steps you through setting up a system

Setting up a new system consists of installing a control enclosure and two file modules and up to nine expansion enclosures.

### Be familiar with the following information

- Where it is applicable, a CAUTION notice indicates situations that can be potentially hazardous to you. Before doing a step that contains a caution notice, read and understand the statement that accompanies it.
- **Sliding drawers:** Do not pull out or install any drawer or feature (like the file module) if the rack stabilizer brackets are not attached to the rack. Do not pull out more than one drawer at a time. The rack might become unstable if you pull out more than one drawer at a time.
- **Fixed drawers:** Any fixed drawer (like the V7000) must not be removed for servicing unless specified by the manufacturer. Attempting to move the drawer partially or completely out of the rack might cause the rack to become unstable or cause the drawer to fall out of the rack.
- Use safe practices when lifting. The fully populated control enclosure weighs about 57.2 lbs (26 kg). Each file module weights 46.5 lbs (21.09 kg) to 55 lbs (25 kg), depending on the configuration. At least two people are required to lift and

install or to remove either unit from the rack.

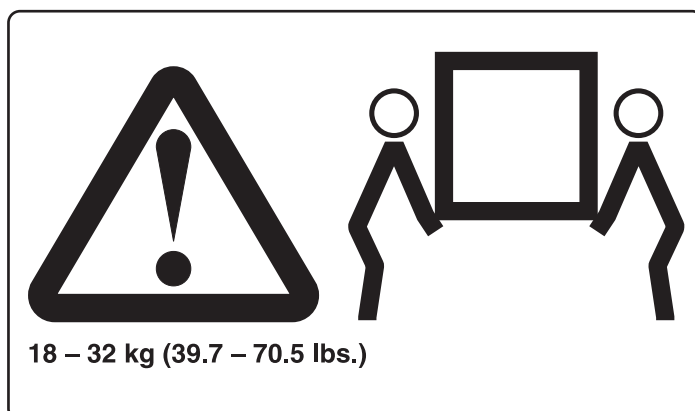

- Do not use rack-mounted devices as a shelf or workspace. Do not place any object on top of rack-mounted devices.

### Tools needed

A screwdriver is the only tool needed for the system installation. The screwdriver can be either a flat-blade screwdriver or a cross head screwdriver.

---

## Step 1. Reviewing your packing slip

After you open your box or boxes, locate your packing slip. Ensure that the items that are listed in your packing slip match what is in the box. Ensure that any optional items that you ordered are included in the list. Your shipment might contain additional items depending on the order.

### Control enclosure ship contents:

- \_\_\_ • Control enclosure (models 2076-112, 2076-124, 2076-312, or 2076-324). The last two digits of the model number identify the number of drive slots, either 12 or 24.
- \_\_\_ • Rack-mounting hardware kit, including:
  - \_\_\_ – Two rails (right and left assembly)
  - \_\_\_ – Two M5 x 15 Hex Phillips screws per rail (two rails)
  - \_\_\_ – Two M5 x 15 Hex Phillips screws per chassis

**Note:** Two parts of the rail kit are attached to each side of the enclosure.

- \_\_\_ • Two power cords
- \_\_\_ • Drive assemblies or blank carriers (installed in the enclosure).  
Verify the number of drives and the size of the drives.

### Other items shipped with control enclosure:

- \_\_\_ • Read first flyer
- \_\_\_ • Quality hotline flyer
- \_\_\_ • Environmental notices CD
- \_\_\_ • Environmental flyers
- \_\_\_ • Safety notices

- \_\_\_ • Limited Warranty information
- \_\_\_ • Documentation DVD that contains the publication PDFs, and the *IBM Storwize V7000 Unified Information Center* content.
- \_\_\_ • License information
- \_\_\_ • License Function authorization document
- \_\_\_ • IBM Storwize V7000 Unified Quick Installation Guide
- \_\_\_ • *Storwize V7000 Unified Problem Determination Guide*
- \_\_\_ • One USB key, also known as a flash drive, is located with the publications.

**Additional components for control enclosure:**

- \_\_\_ • Fibre Channel cables, if ordered
- \_\_\_ • Small form-factor pluggable (SFP) transceivers that are preinstalled in the enclosure
- \_\_\_ • Longwave SFP transceivers, if ordered

**Additional components for expansion enclosures:**

- \_\_\_ • Two SAS cables for each expansion enclosure

**Two file modules. Each file module box contains:**

- \_\_\_ • File module (server)
- \_\_\_ • Rack-mounting hardware kit, including:
  - \_\_\_ – Two sets of two rails (right and left assembly)
  - \_\_\_ – Large cable tie
  - \_\_\_ – Cable ties
  - \_\_\_ – Two sets of four M6 screws per rail (two rails)
  - \_\_\_ – Two sets of two 10-32 screws per chassis
  - \_\_\_ – Cable management support arm
  - \_\_\_ – Cable management arm mounting bracket
  - \_\_\_ – Cable management arm stop bracket
  - \_\_\_ – Cable management arm assembly

**Note:** The rail kits for the servers differ from the control enclosure.

- \_\_\_ • Two power cords

**Additional components for file modules:**

- \_\_\_ • Read first flyer
- \_\_\_ • Quality hotline flyer
- \_\_\_ • Environmental notices CD
- \_\_\_ • Environmental flyers
- \_\_\_ • Safety notices
- \_\_\_ • Limited warranty information
- \_\_\_ • License information
- \_\_\_ • License Function authorization document
- \_\_\_ • Small form-factor pluggable (SFP) transceivers that are preinstalled in the enclosure

## Step 2. Identifying the hardware components

The following graphics and descriptions identify the various hardware components and port locations for the control enclosure, expansion enclosure, and file modules.

### Control enclosure

Each enclosure has drives that are located on the front. Figure 1 and Figure 2 show the front of an enclosure that has space for up to 12 or 24 drives **2**, depending on the model, and a left end cap **1** and a right end cap **3**.

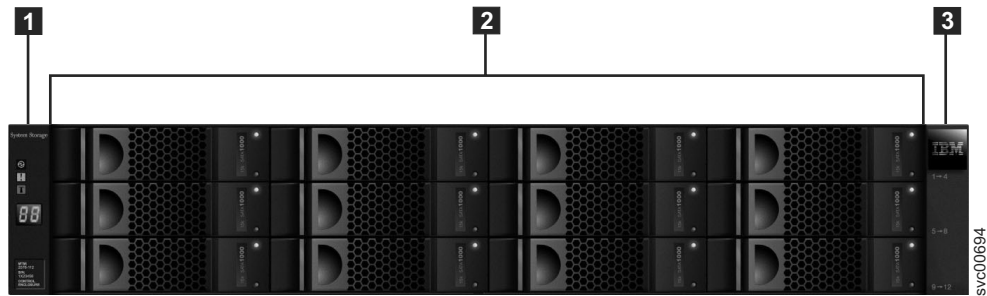

Figure 1. This figure shows 12 drives and two end caps (model 2076-112).



Figure 2. This figure shows 24 drives and two end caps (model 2076-124).

### Control enclosure components

Figure 3 shows the rear view of a control enclosure and identifies the location of the power supply units and the canisters.

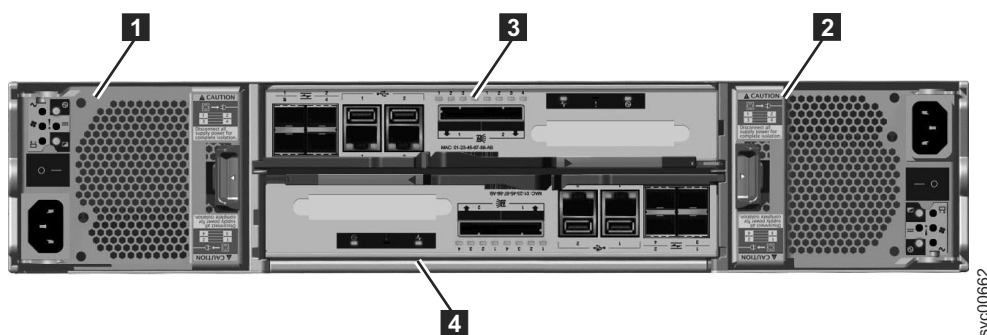

Figure 3. Rear view of a model 2076-112 or a model 2076-124 control enclosure

- Power supply units are located on the left and right of the canisters. Each unit contains a battery. Power supply **1** is located on the left. Power supply **2** is

located on the right. Power supply **1** is inserted top side up, and power supply **2** is inverted, or top side down.

**Important:** The power supply units for the control enclosure and expansion enclosure are not interchangeable.

- Two canisters are housed in the middle of the enclosure. Each canister is known as a node canister. The upper canister, as shown in Figure 3 on page 4, is labelled **3**, and the lower canister is labelled **4**. Canister **3** is top side up, and canister **4** is inverted, or top side down.

Figure 4 shows the rear view of a model 2076-112 or a model 2076-124 control enclosure and identifies the location of the ports.

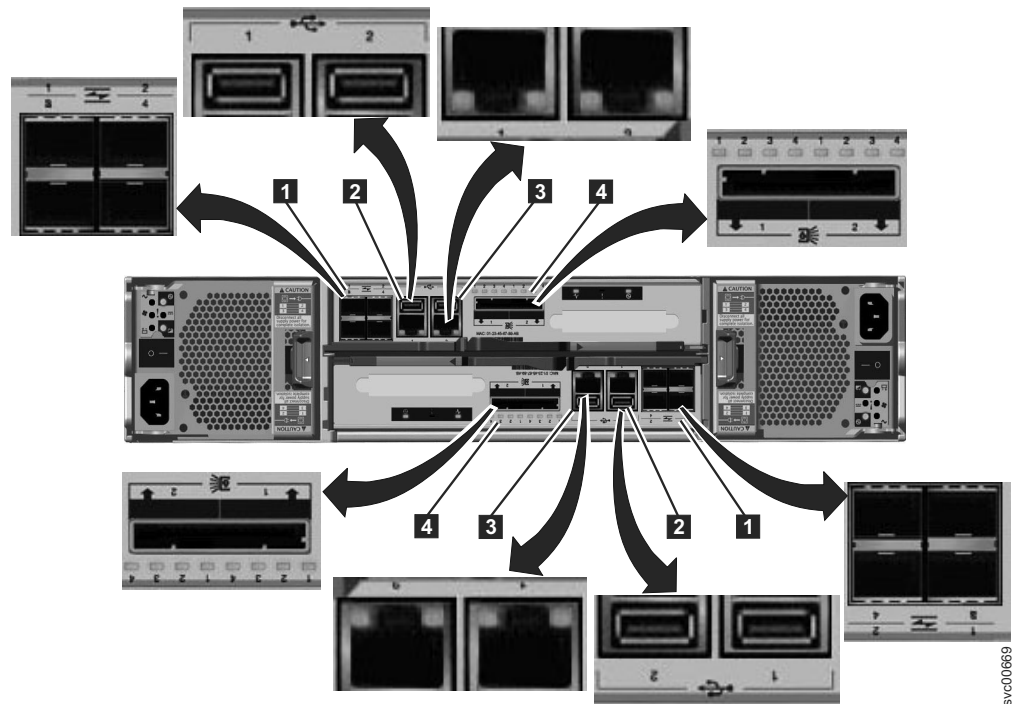

Figure 4. This figure shows the data ports in the rear of the control enclosure.

- **1** Fibre Channel ports. Each canister has four Fibre Channel ports. They are in a block of four in two rows of two connectors. The ports are numbered 1 - 4 from left to right, top to bottom. Two ports connect to the file modules and two are optional.
- **2** USB ports. Each canister has two USB ports. The ports are side by side on the canister and are numbered 1 on the left and 2 on the right. One port is used during installation.
- **3** Ethernet ports. Each canister has two Ethernet ports. The ports are side by side on the canister. They are numbered 1 on the left and 2 on the right on the upper canister. The port locations are inverted for the lower canister. Port 1 must be connected first; the use of port 2 is optional.
- **4** Serial-attached SCSI (SAS) ports. Each canister has two SAS ports. The ports are side by side on the canister. They are numbered 1 on the left and 2 on the right. Port 1 must be connected first if you are adding one expansion enclosure. Port 2 must be connected if you are adding a second expansion enclosure.

**Note:** The reference to the left and right locations applies to canister 1, which is the upper canister. The port locations are inverted for canister 2, which is the lower canister.

Figure 5 shows the rear view of a model 2076-312 or a model 2076-324 control enclosure with the optional 10 Gbps Ethernet ports installed. All other ports remain the same.

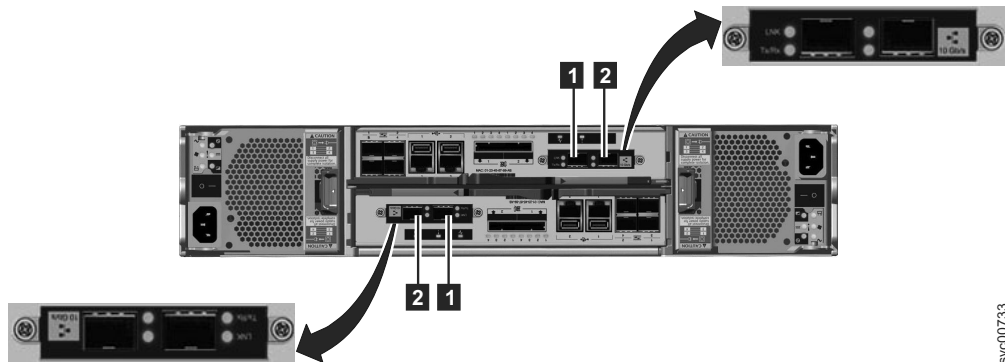

Figure 5. 10 Gbps Ethernet ports on the rear of the Storwize V7000 enclosure

- **1** 10 Gbps Ethernet port 3 which is the left port.
- **2** 10 Gbps Ethernet port 4 which is the right port.

## Expansion enclosure components

Figure 6 shows the rear view of an expansion enclosure and identifies the location of the power supply units and the canisters. The ports and their use are described later in this section.

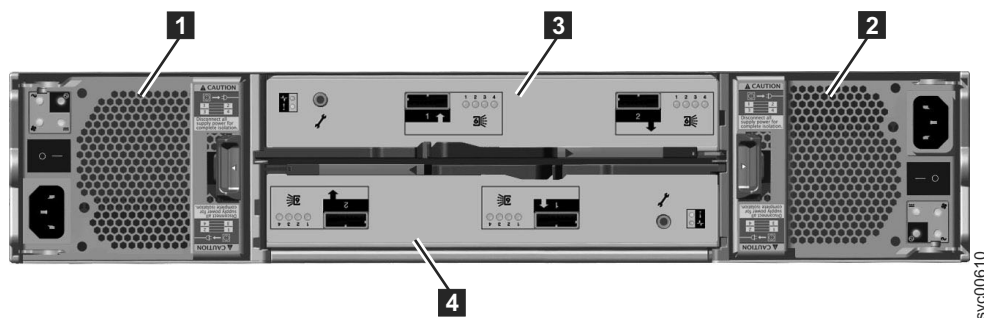

Figure 6. Rear view of a model 2076-212 or a model 2076-224 expansion enclosure

- Power supply units are on the left and right of the canisters. Power supply **1** is located on the left. Power supply **2** is located on the right. Power supply 1 is inserted top side up, and power supply 2 is inverted, or top side down.

**Important:** The power supply units for the control enclosure and expansion enclosure are not interchangeable.

- Two canisters are housed in the middle of the enclosure. Each canister is known as an expansion canister. The upper canister, as shown in Figure 6, is canister **3**, and the lower canister is canister **4**. Canister 3 is top side up, and canister 4 is inverted, or top side down.



Figure 7 shows the rear view of an expansion enclosure and identifies the SAS port locations.

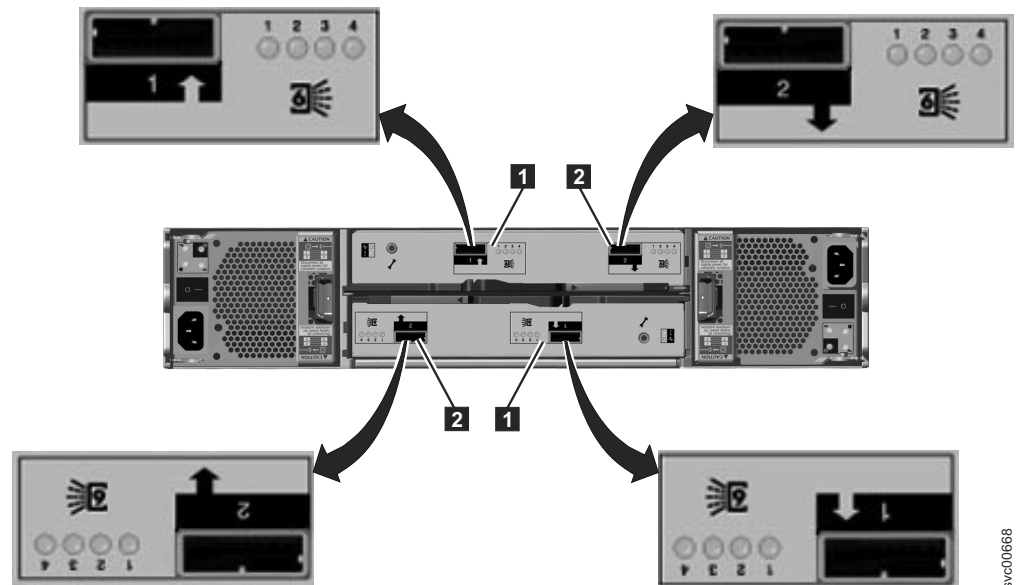

Figure 7. SAS ports and LEDs in rear of expansion enclosure

Each canister has two SAS ports that are numbered 1 on the left **1** and 2 on the right **2**. Port 1 must be connected if you are adding one expansion enclosure. Port 2 must be connected if you are adding a second expansion enclosure.

**Note:** The reference to the left and right locations applies to canister 1, which is the upper canister. The port locations are inverted for canister 2, which is the lower canister.

## File module

Figure 8 on page 8 identifies the various front ports and hardware for the file module:

- **1** VGA port
- **2** USB ports
- **3** CD drive
- **4** Control panel
- **5** Two drives

Each enclosure takes up the full 2U height in the rack. See the *Storwize V7000 Unified Problem Determination Guide* PDF on the CD for the full descriptions of the hardware components.

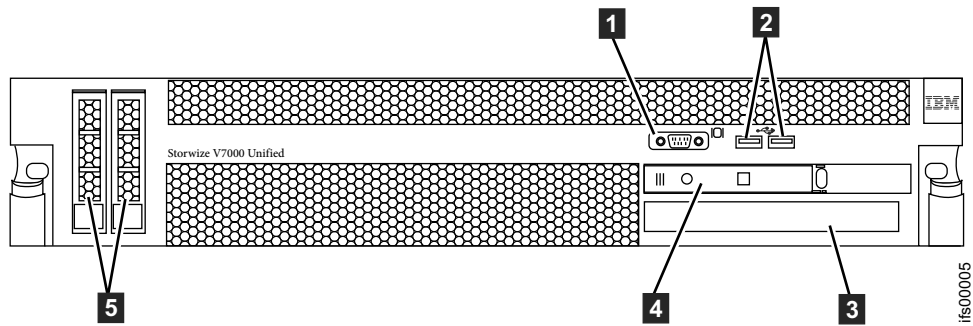

Figure 8. Front view of file module

Figure 9 identifies the various rear ports and hardware for the file module:

- **1** Fibre Channel ports, right is port 1, left is port 2
- **2** 10 Gbps Ethernet ports, right is port 0, left is port 1
- **3** Power supply
- **4** USB ports
- **5** Serial port
- **6** Video port
- **7** 1 Gbps Ethernet ports, left is port 1, right is port 2
- **8** 1 Gbps Ethernet ports, left is port 3, right is port 4
- **9** Not used

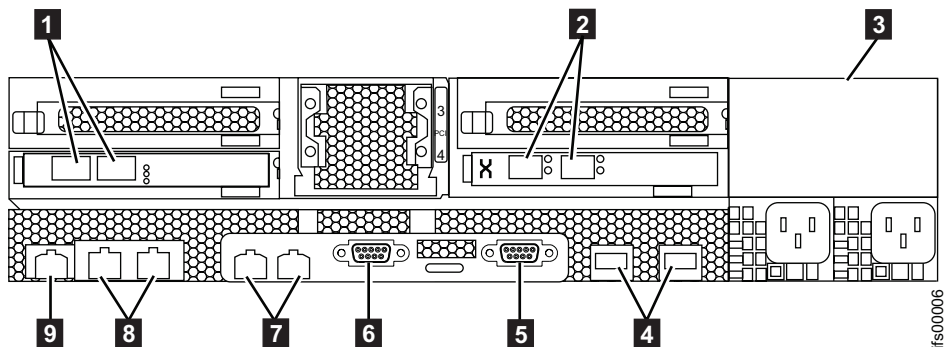

Figure 9. Rear view of file module

### Miscellaneous hardware

The USB key (also known as a USB flash drive) is packaged with the publications and contains the initialization tool for performing the initial system configuration.

## Step 3. Verifying environmental requirements

Certain requirements for the physical site must be met to ensure that your system works reliably. This step includes verifying that adequate space in a suitable rack is available and that requirements for power and environmental conditions are met. This documentation assumes that you have completed the physical planning for the environment of your system.

If you have not done the environmental planning for your system, see the *Storwize V7000 Unified physical installation planning* topic in the Storwize V7000 Unified Information Center.

You must use a supported web browser. Verify that you are using a supported web browser from the following website:

Support for Storwize V7000 Unified website at [www.ibm.com/storage/support/storwize/v7000/unified](http://www.ibm.com/storage/support/storwize/v7000/unified)

1. From the **Search support** input field, type browser.  
You are shown a search result for “IBM Storwize V7000 Unified Supported Hardware List, Device Driver, Firmware and Recommended Software Levels.” Click the search entry.
2. Scroll down to the **Other Hardware and Software** section.
3. Find and select **Management GUI**.

---

## Step 4. Reviewing enclosure location guidelines

### Control enclosure:

Follow these guidelines to create a plan that identifies an appropriate location in the rack for the enclosure and file modules that you are installing now or will be installing later.

**Note:** These guidelines assume that you are installing a new enclosure or enclosures. If you are adding enclosures to an existing rack, you must consider the amount of space available and the length of cables to the enclosure.

### If you are installing a control enclosure only, follow these guidelines:

Position the enclosure in the rack so that you can easily view it and access it for servicing. This action helps the rack to remain stable and provides a way for two or more people to install and remove the enclosure.

### If you are installing a control enclosure plus one or more expansion enclosures, follow these guidelines:

If you have one or more expansion enclosures, position the control enclosure in the middle of the expansion enclosures. Balance the expansion enclosures above and below the control enclosure. Refer to Figure 10 on page 11.

For example, position the control enclosure in the middle of the enclosures for ease of cabling.

- You can have no more than five expansion enclosures attached to SAS port 1 of the control enclosure.
- You can have no more than four expansion enclosures attached to SAS port 2 of the control enclosure.
- Position the enclosures together; avoid adding other equipment between enclosures.
- When you add the first expansion enclosure to a control enclosure, it is preferable to add the enclosure directly below the control enclosure.

- When you add a second expansion enclosure, it is preferable to add the enclosure directly above the control enclosure. For each additional expansion enclosure that you add, alternately add it below or above the control enclosure.
- Position the enclosures in the rack so that you can easily view them and access them for servicing. This action helps the rack to remain stable and provides a way for two or more people to install and remove the enclosures.

**If you are installing an expansion enclosure to an existing system, follow these guidelines:**

When you add the first expansion enclosure to a control enclosure, it is preferable to add the enclosure directly below the control enclosure. When you add a second expansion enclosure, it is preferable to add the enclosure directly above the control enclosure. For each expansion enclosure that you add, alternately add it below or above the control enclosure. Refer to Figure 10 on page 11.

If you are adding an expansion enclosure to an existing system, you do not need to power off the system. You can add an expansion enclosure while the system is operational.

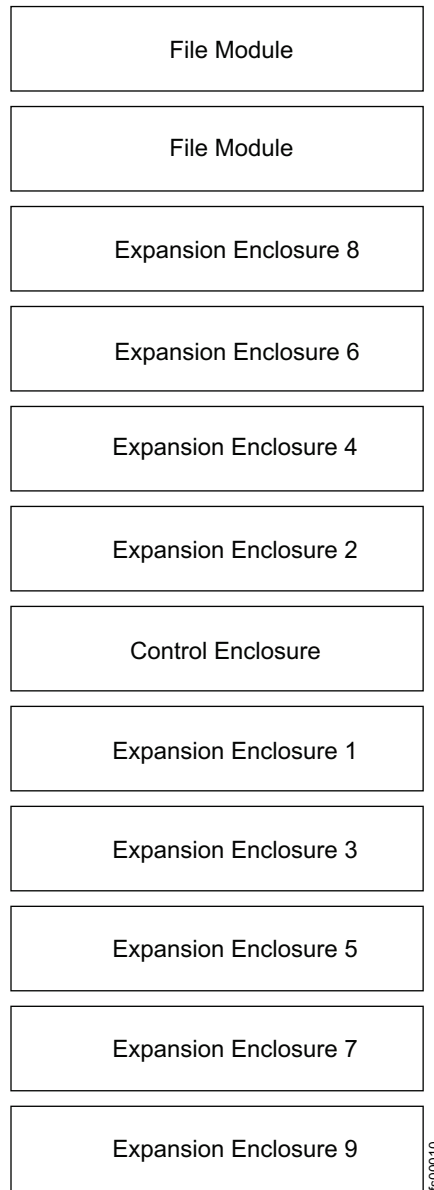

Figure 10. Recommended rack locations

**File modules:**

- Install both file modules in adjacent slots, near the control enclosure. Other configurations are possible, but all racks must be close together to accommodate cable lengths. A floor plan showing the layout must be developed prior to the start of the installation.



---

## Chapter 2. Performing the hardware installation

You have completed the initial steps of verifying the shipping contents and becoming familiar with the hardware components. You have verified that the power and environmental requirements are met and have planned the location of the enclosures and file modules. You are now ready to begin installing the hardware components and connecting the data cables and power cords.

---

### Step 5. Installing the support rails for control enclosure

Review the documentation that comes with the rack cabinet for safety and cabling information. Before you install the control enclosure in a rack cabinet, review the following guidelines

- Two or more people are required to install devices 2U or larger in a rack cabinet.
- Make sure that the room air temperature is below 35°C (95°F).
- Do not block any air vents; usually 15 cm (6 inch) of space provides proper airflow.
- Do not leave open spaces above or below an installed control enclosure in the rack cabinet. To help prevent damage to control enclosure components, always install a blank filler panel to cover the open space and to help ensure proper air circulation. Install the control enclosure only in a rack cabinet with perforated doors.
- Plan the device installation starting from the bottom of the rack cabinet.
- Install the heaviest device in the bottom of the rack cabinet.
- Do not extend more than one device out of the rack cabinet at the same time.
- Remove the rack doors and side panels to provide easier access during installation.
- Connect the control enclosure to a properly grounded outlet.
- Do not overload the power outlet when you install multiple devices in the rack cabinet.
- Install the control enclosure in a rack that meets the following requirements:
  - Minimum depth of 70 mm (2.76 inch) between the front mounting flange and inside of the front door.
  - Minimum depth of 157 mm (6.18 inch) between the rear mounting flange and inside of the rear door.



Figure 11. Securing an enclosure to a rack cabinet

- Minimum depth of 718 mm (28.27 inch) and maximum depth of 762 mm (30 inch) between the front and rear mounting flanges to support the use of the cable management arm.

To install the support rails, perform the following steps:

1. Locate the rack mounting rails and screws.

The rail assembly is made up of two sets of rails. One set of rails is already installed, or preinstalled, on the sides of the enclosures. The other set of rails must be installed in the rack cabinet. The rails on the sides of the enclosures slide into the rails that are installed in the rack cabinet.

2. Working at the front of the rack cabinet, identify the two standard rack units of space in the rack into which you want to install the support rails.

Figure 12 on page 15 shows two rack units with the front mounting holes identified.



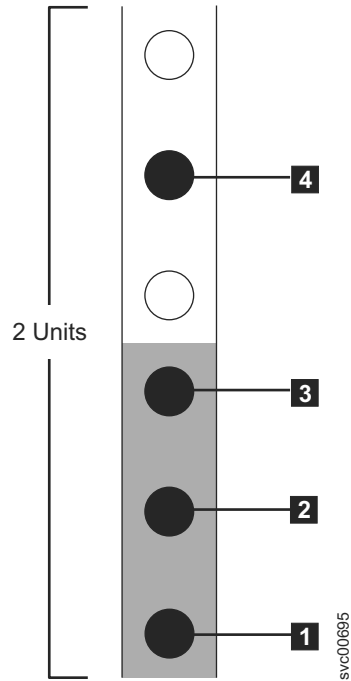

Figure 12. Hole locations in the front of the rack

- **1** Bottom rail location pin hole
  - **2** Enclosure mounting screw hole. Do not insert the screw until the enclosure is installed.
  - **3** Rack mounting screw hole
  - **4** Top rail location pin hole
3. Align the bottom of the rail with the bottom of the two rack units. Insert the rail location pins **1** and **4** through the holes in the rack cabinet.
  4. Insert a clamping screw into the rack mounting hole **3** between the rail location pins.
  5. Tighten the screw to secure the rail to the rack.
  6. Working from the rear of the rack cabinet, extend the rail that you secured to the front to align the bottom of the rail with the bottom of the two rack units.

**Note:** Ensure that the rail is level between the front and the back.

Figure 13 on page 16 shows two rack units with the back mounting holes identified.

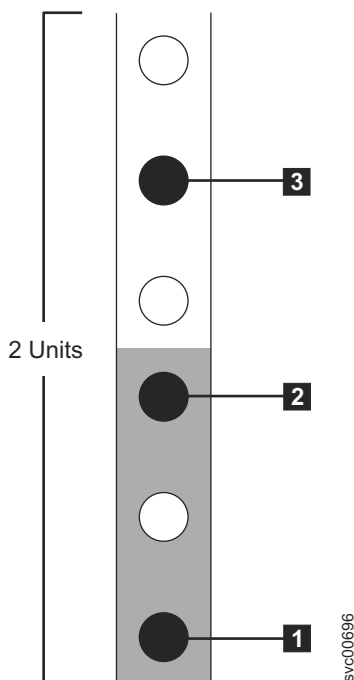

Figure 13. Hole locations in the back of the rack

- **1** Bottom rail location pin hole
  - **2** Rack mounting screw hole
  - **3** Top rail location pin hole
7. Insert the rail location pins through the holes **1** and **3** in the rack cabinet.
  8. Insert a clamping screw into the rack mounting hole **2** between the rail location pins.
  9. Tighten the screw to secure the rail to the rack from the back side.
  10. Repeat the steps to secure the opposite rail to the rack cabinet.
  11. Repeat the procedure for each additional enclosure.

---

## Step 6. Installing the enclosures

### CAUTION:

1. To lift and install the enclosure into the rack requires at least two people.
2. Load the rack from the bottom to ensure rack stability. Empty the rack from the top down.

Following your enclosure location plan, install the correct type of enclosure starting from the bottom.

1. On either side of the drive assemblies, remove the enclosure end caps by squeezing the middle of the cap and pulling it away from the front of the enclosure .



Figure 14. Removing the enclosure end cap

2. Align the enclosure with the front of the rack cabinet.
3. Carefully slide the enclosure into the rack along the rails until the enclosure is fully inserted.

**Notes:**

- a. The preinstalled rails on the sides of the enclosure must fit into the rack-mounted rails that you previously installed.
  - b. The rails are not designed to hold an enclosure that is partially inserted. The enclosure must always be in a fully inserted position.
  - c. Do not have more than one enclosure extended out of the rack at the same time to avoid the danger of the rack toppling over.
4. Insert a screw into the hole behind each enclosure end cap and tighten the screw.



Figure 15. Securing an enclosure to a rack cabinet

5. After matching each end cap's serial number to the serial number found on the rear of each enclosure, push the end caps back into position.
6. Repeat this procedure for each additional enclosure that you install.

---

## Step 7. Installing the support rails for file module slides

Review the documentation that comes with the rack cabinet for safety and cabling information. Before you install the file module in a rack cabinet, review the following guidelines:

- Two or more people are required to install devices 2U or larger in a rack cabinet.
- Make sure that the room air temperature is below 35°C (95°F).
- Do not block any air vents; usually 15 cm (6 inch) of space provides proper airflow.
- Do not leave open spaces above or below an installed file module in the rack cabinet. To help prevent damage to file module components, always install a blank filler panel to cover the open space and to help ensure proper air circulation.
- Install the file module only in a rack cabinet with perforated doors.
- Plan the device installation starting from the bottom of the rack cabinet.
- Install the heaviest device in the bottom of the rack cabinet.
- Do not extend more than one device out of the rack cabinet at the same time.
- Remove the rack doors and side panels to provide easier access during installation.
- Do not overload the power outlet when you install multiple devices in the rack cabinet.
- Install the file module in a rack that meets the following requirements:
  - Minimum depth of 70 mm (2.76 inch) between the front mounting flange and inside of the front door.
  - Minimum depth of 157 mm (6.18 inch) between the rear mounting flange and inside of the rear door.

- Minimum depth of 718 mm (28.27 inch) and maximum depth of 762 mm (30 inch) between the front and rear mounting flanges to support the use of the cable management arm.

**Note:** The maximum distance between the front and the rear EIA rails of the rack is 810 mm (31.9 inch). Also, cage nuts and clip nuts are not required to install the file module in a rack cabinet.

- Install the cable management arm on either side of the file module. These instructions are shown with the cable management arm mounted on the left side. The installation instructions in this document can be reversed if you are installing the cable management arm on the side of the file module not shown.

The following illustration shows the items that you need to install the file module in the rack cabinet. If any items are missing or damaged, contact your place of purchase. The contents from the slide rail box and the cable management arm box are necessary for this installation.

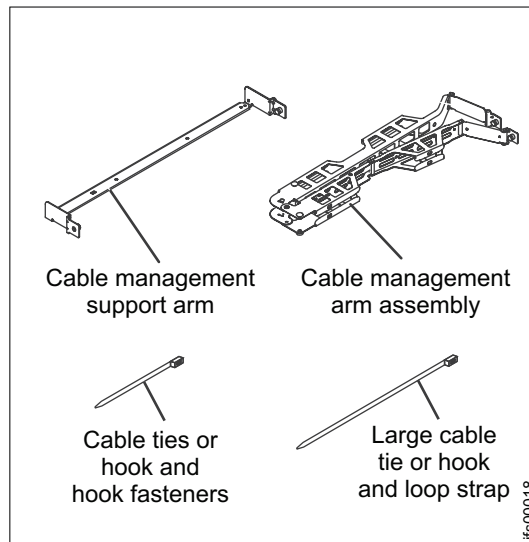

Figure 16. Cable management arm box contents.

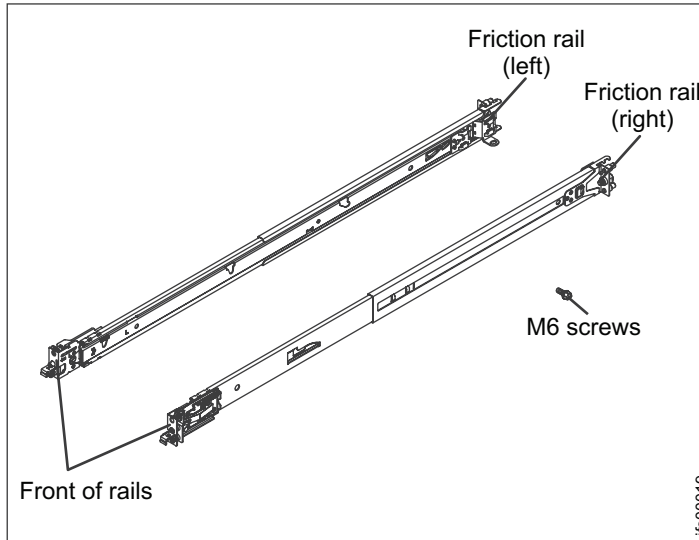

Figure 17. Friction rail box contents.

If the slide rails in your rack installation kit came with shipping thumbscrews, remove them before you begin the following installation procedure.

Follow these installation instructions:

1. Select an available 2U space in the rack to install the file modules.

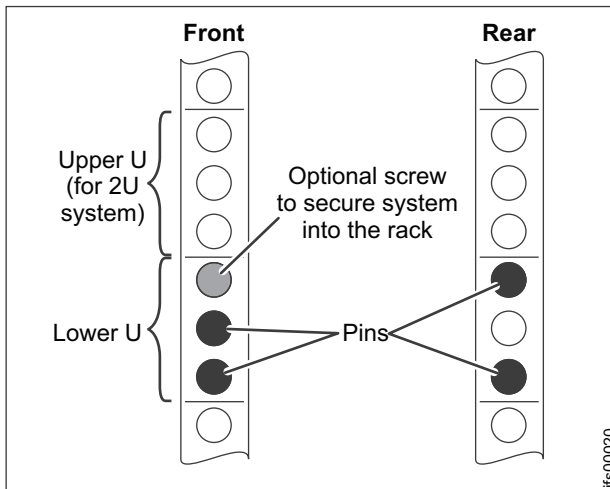

Figure 18. Locate a 2U space in the lower section of the rack.

2. Each slide rail is marked with either an R (right) or an L (left). Select one of the slide rails and pull the rear bracket all the way back. If a thumbscrew is installed in the slide rail, remove it.

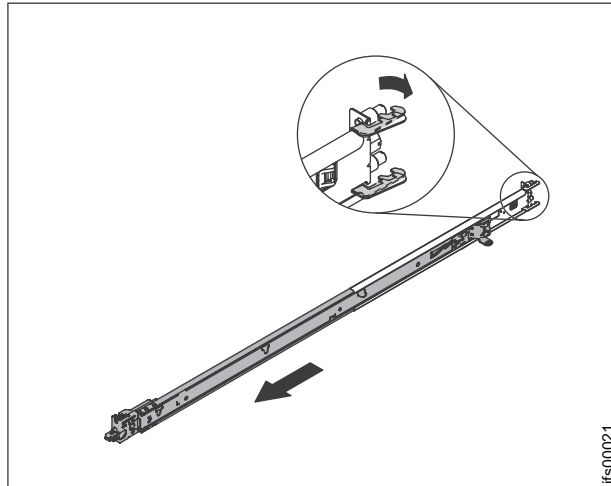

Figure 19. Open the rear slide rail hooks.

3.

**Note:** If you are installing the slide rails into a 1U space with devices already installed directly above and below this 1U space, you need to extend the slide rails to slide the rear of the slide rails into the rear of the rack. When installing a 2U device, be sure to install the slide rails in the bottom position of the 2U area in the rack.

From the front of the rack, line up the two pins on the rear of the slide rail in the selected unit on the rear of the rack. Push the rails so that the pins go into the holes and slide the rails into the rack to lock the rear of the slide rails into the rack.

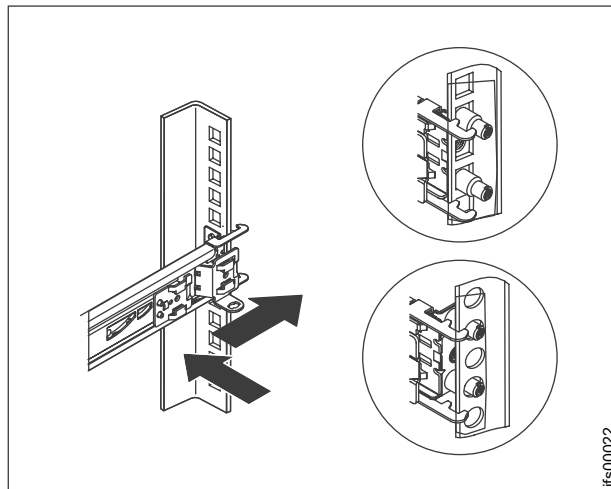

Figure 20. Install the rear end of the slide rails.

4. Push the blue button to allow the latch to slide forward. Then pull the slide rail forward and locate the front latch in the appropriate unit space in front of the rack EIA rail. Adjust the length of the rail.

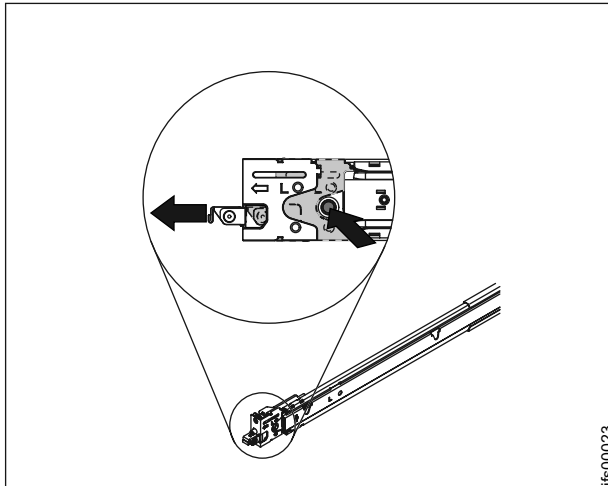

Figure 21. Install the front end of the slide rails.

5. Press the blue button to release the bracket. Push the front latch in all the way. Make sure the latch is fully engaged. Repeat steps 1 through 5 to install the other rail into the rack. Make sure that each front latch is fully engaged.

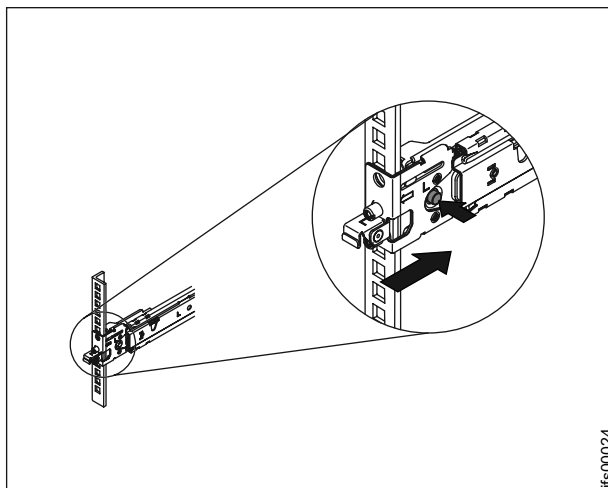

Figure 22. Install the front end of the slide rails.

---

## Step 8. Installing the file modules

To install each file module in the rack, follow these instructions:

1. Pull the slide rails forward **1** until they click, two times, into place. Carefully lift the file module and tilt it into position over the slide rails so that the rear nail heads **2** on the device line up with the slide rails. Slide the file module down until the rear nail heads slip into the two rear slots, and then slowly lower the front of the file module **3** until the other nail heads slip into the other slots on the slide rails.



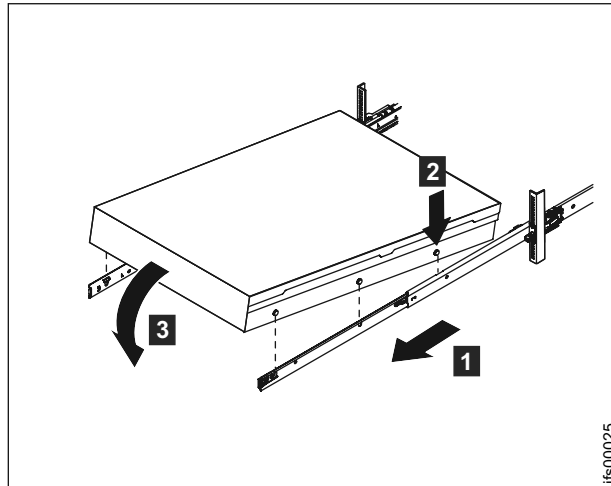

Figure 23. Install the file module on the slide rails.

2. Lift the locking levers **1** on the slide rails and push the file module **2** all the way into the rack until it clicks into place.

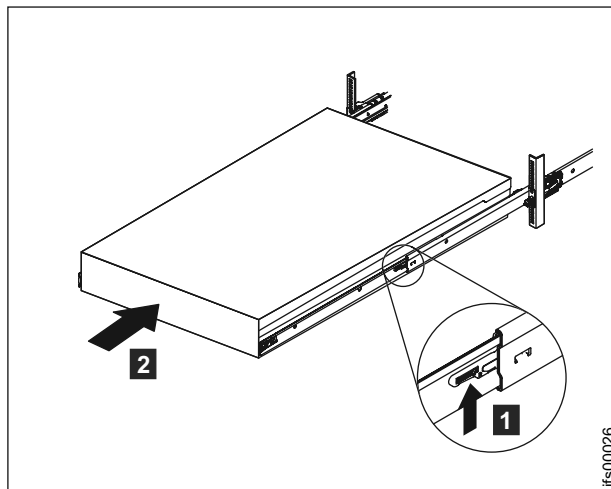

Figure 24. Slide the file module into the rack.

3. Insert both ends of the cable management support arm to the slide rail.

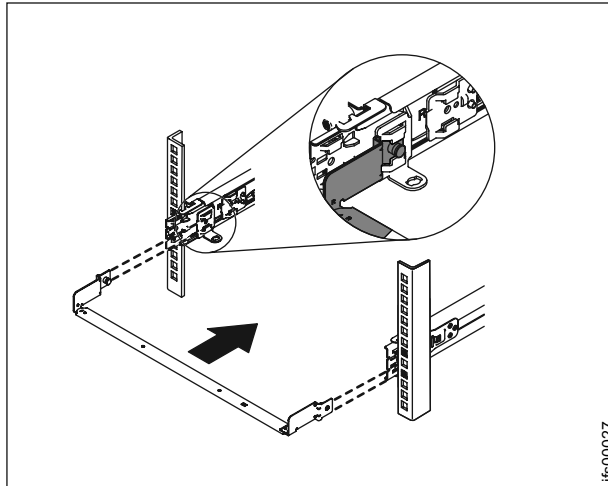

Figure 25. Install the cable management support arm. It can be installed on either side (left or right). The graphic shows the rear of the rack.

4.

**Note:** Make sure the arm with junctions is facing the file module. Place the cable management arm on the support arm. Pull out both cable management arm pins and then slide the cable management arm tabs into the slots on both inside and outside of the slide rail. Push the tabs until they snap into place.

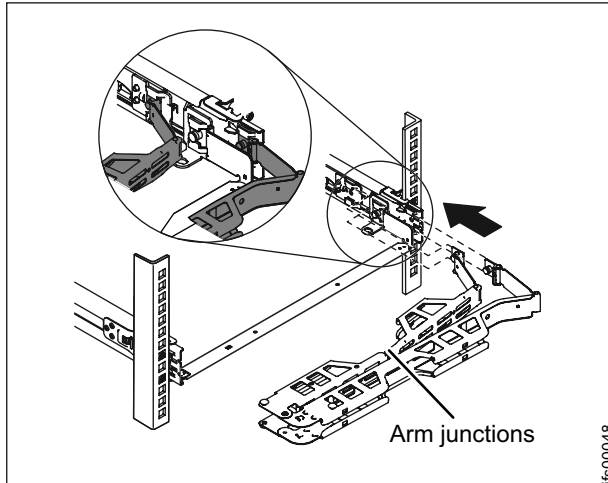

Figure 26. Install the cable management arm.

5. Make sure that the support rail is located between the 2 nail head features.

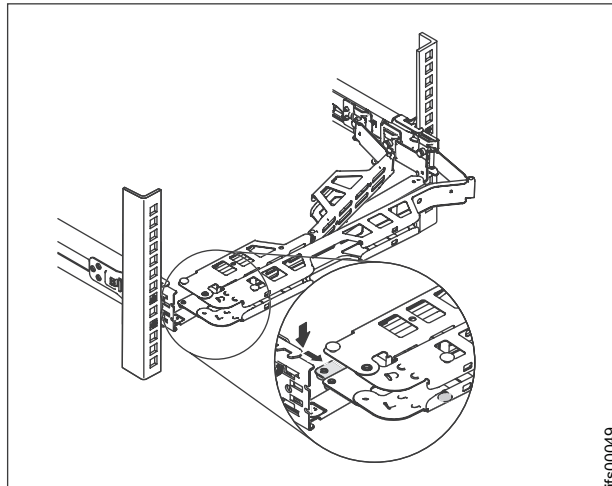

Figure 27. Adjust the location of the cable management arm.

6. Attach the power cords and other cables to the rear of the file module (including keyboard, monitor, and mouse cables, if required).  
Route the cables and power cords on the cable management arm **1** and secure them with cable ties or hook-and-loop fasteners.

**Note:** Allow slack in all cables to avoid tension in the cables as the cable management arm moves.

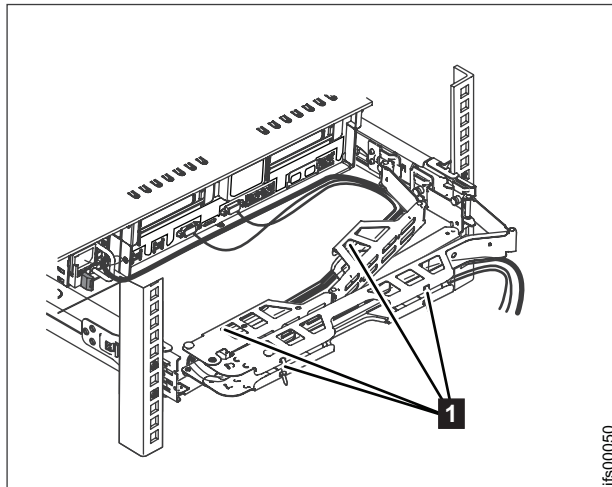

Figure 28. Connect and route the cables.

7. Insert the M6 screws to the rear of the slides. Use a cable tie to secure the free end of the cable management arm to the rack, if needed.

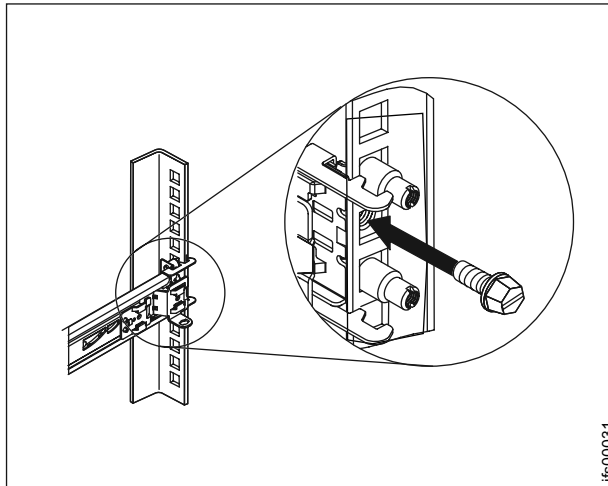

Figure 29. Secure the cable management arm and the file module in the rack for shipping if needed.

8. Slide the file module into the rack until it snaps into place. To slide the file module out of the rack, press on the release latches **1**.

**Note:** When you move the rack cabinet, or if you install the rack cabinet in a vibration-prone area, insert the M6 screws **2** in the front of the file module.

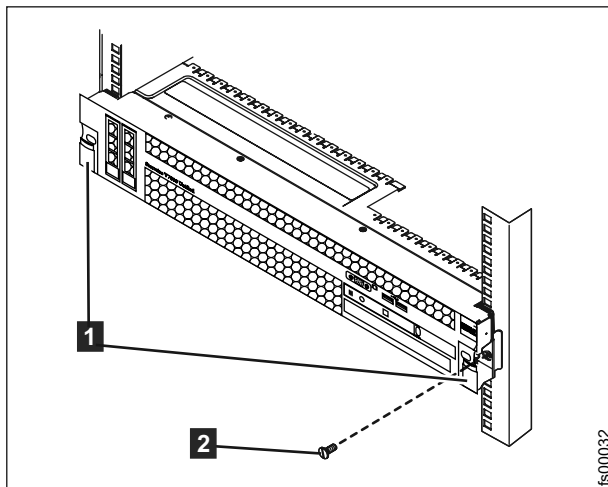

Figure 30. Install the front screws.

---

## Step 9. Connecting the SAS cables to the expansion enclosures

This task applies if you are installing one or more expansion enclosures.

**Note:** The enclosure terminology that is used in this topic is described fully in “Step 2. Identifying the hardware components” on page 4.

Be aware of these guidelines when you begin to attach the cables to the SAS ports:

- No more than five expansion enclosures can be chained to port 1 (below the control enclosure). The connecting sequence from port 1 of the node canister is called chain 1.

- No more than four expansion enclosures can be chained to port 2 (above the control enclosure). The connecting sequence from port 2 of the node canister is called chain 2.
- No cable can be connected between a port on an upper canister and a port on a lower canister.
- Attach cables serially between enclosures; do not skip an enclosure.
- The last enclosure in a chain must not have cables in port 2 of canister 1 and port 2 of canister 2.
- Ensure that cables are installed in a tidy manner to reduce the risk of cable damage when Storwize V7000 Unified replaceable units are removed or inserted.
- Arrange your cables to provide access to:
  - The USB ports. Access is required to this port when you use the USB key to configure the system.
  - The enclosures themselves. Access is required to the hardware for servicing and for safely removing and replacing components using two or more people.
- Ensure that each SAS cable is fully inserted. A click is heard when the cable is successfully inserted.

**Note:** If you make a mistake during cabling and must unplug a SAS cable, pull the blue tag to release the cable.

*Table 1. Use this table to identify the file module, control enclosure, and expansion unit port locations for Figure 31 on page 28. Follow the links to identify detailed port locations.*

Key	Description	
<b>A</b>	Upper file module. See Figure 9 on page 8 for detailed port locations.	<b>1</b> Fibre Channel slot 2, port 2 <b>2</b> Fibre Channel slot 2, port 1
<b>B</b>	Lower file module. See Figure 9 on page 8 for detailed port locations.	Ports are identical to file module <b>A</b>
<b>C</b>	Control enclosure. This unit consists of two canisters; the upper and the lower. The lower canister is position upside down. See Figure 3 on page 4 for detailed port locations.	<b>3</b> Fibre Channel port 1 <b>4</b> Fibre Channel port 2 <b>5</b> SAS port 1 <b>6</b> SAS port 2
<b>D</b>	Expansion enclosure. This configuration is for enclosure units 1, 3, 5. This unit consists of two canisters; the upper and the lower. The lower canister is position upside down. See Figure 6 on page 6 for detailed port locations.	<b>Note:</b> All port locations are identical for <b>D</b> through <b>E</b> <b>7</b> SAS port 1 <b>8</b> SAS port 2 The lower unit is upside down: <b>9</b> SAS port 2 <b>10</b> SAS port 1
<b>E</b>	Expansion enclosure. This configuration is for enclosure units 2, 4, 6. This unit consists of two canisters; the upper and the lower. The lower canister is position upside down. See Figure 6 on page 6 for detailed port locations.	Ports are identical to <b>D</b> .

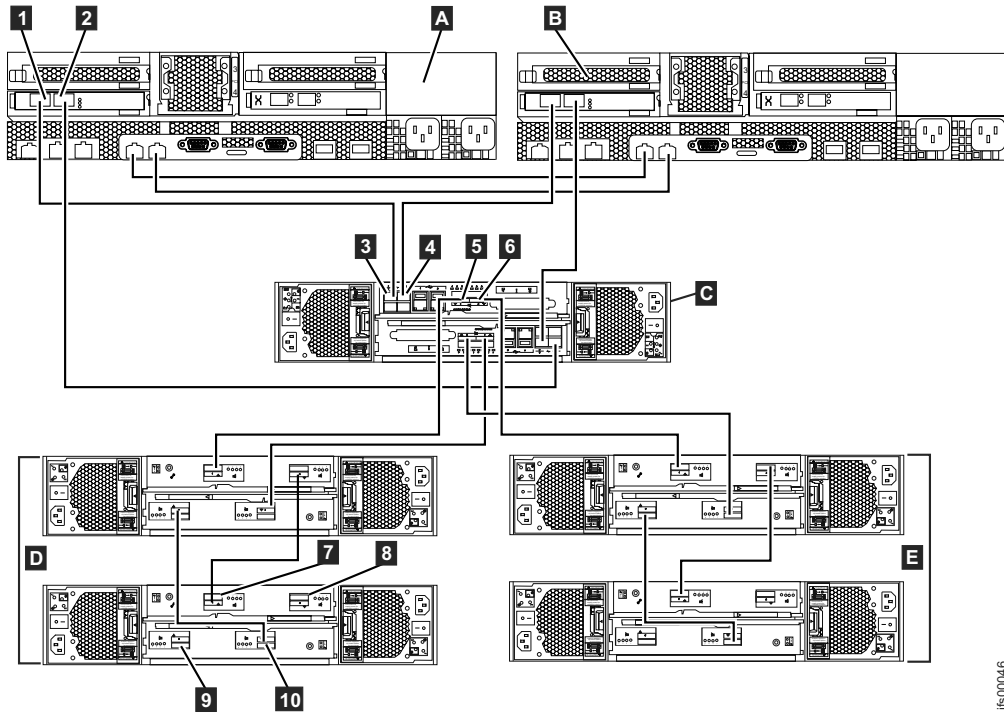

Figure 31. Internal cabling connections between file modules ([A] & [B]), control enclosure ([C]), and expansion enclosures ([D] & [E]).

1. Review Table 2 and the figures before attaching the SAS cables.

Table 2. How to connect SAS cables to expansion units. Refer to Figure 31.

SAS Connections: How the first unit connects to the second unit		
First Unit	Second Unit	Number of Expansions
<b>Controller</b>	<b>Expansion 1</b>	<b>1 Expansions</b>
Upper canister port 1	Upper canister port 1	
Lower canister port 1	Lower canister port 1	
<b>Controller</b>	<b>Expansion 2</b>	<b>2 Expansions</b>
Upper canister port 2	Upper canister port 1	
Lower canister port 2	Lower canister port 1	
<b>Expansion 1</b>	<b>Expansion 3</b>	<b>3 Expansions</b>
Upper canister port 2	Upper canister port 1	
Lower canister port 2	Lower canister port 1	
<b>Expansion 2</b>	<b>Expansion 4</b>	<b>4 Expansions</b>
Upper canister port 2	Upper canister port 1	
Lower canister port 2	Lower canister port 1	
<b>Expansion 3</b>	<b>Expansion 5</b>	<b>5 Expansions</b>
Upper canister port 2	Upper canister port 1	
Lower canister port 2	Lower canister port 1	
<b>Expansion 4</b>	<b>Expansion 6</b>	<b>6 Expansions</b>
Upper canister port 2	Upper canister port 1	
Lower canister port 2	Lower canister port 1	

ifs00046

Table 2. How to connect SAS cables to expansion units. Refer to Figure 31 on page 28. (continued)

SAS Connections: How the first unit connects to the second unit		
First Unit	Second Unit	Number of Expansions
Expansion 5	Expansion 7	7 Expansions
Upper canister port 2	Upper canister port 1	
Lower canister port 2	Lower canister port 1	
Expansion 6	Expansion 8	8 Expansions
Upper canister port 2	Upper canister port 1	
Lower canister port 2	Lower canister port 1	
Expansion 7	Expansion 9	9 Expansions
Upper canister port 2	Upper canister port 1	
Lower canister port 2	Lower canister port 1	

2. Attach the SAS cables from the control enclosure to the first expansion enclosure as shown in Figure 32. Remove the protective end covers, if necessary. The first expansion enclosure is below the control enclosure.

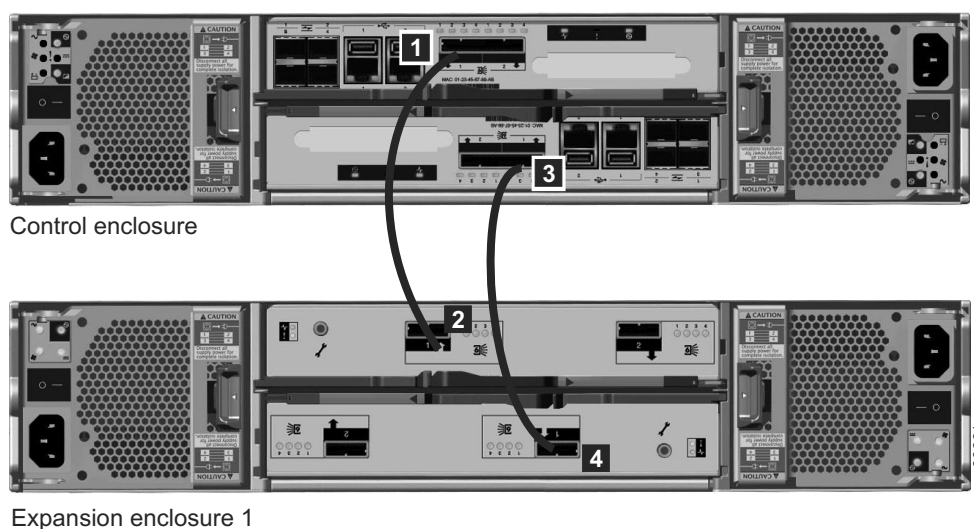

Figure 32. Attaching an expansion enclosure to the control enclosure

- a. Port 1 **1** of the upper canister, control enclosure, attaches to Port 1 **2** of the upper canister, expansion enclosure 1.
- b. Port 1 **3** of the lower canister, control enclosure, attaches to Port 1 **4** of the lower canister, expansion enclosure 1. The port locations on the lower canister are inverted from the port locations on the upper canister. Port 1 on the lower canister is opposite port 1 on the upper canister.

**Note:** The connecting sequence from port 1 of the node canister is called chain 1.

3. Attach the SAS cables from the control enclosure to the second expansion enclosure as shown in Figure 33 on page 30. The second expansion enclosure is above the control enclosure.

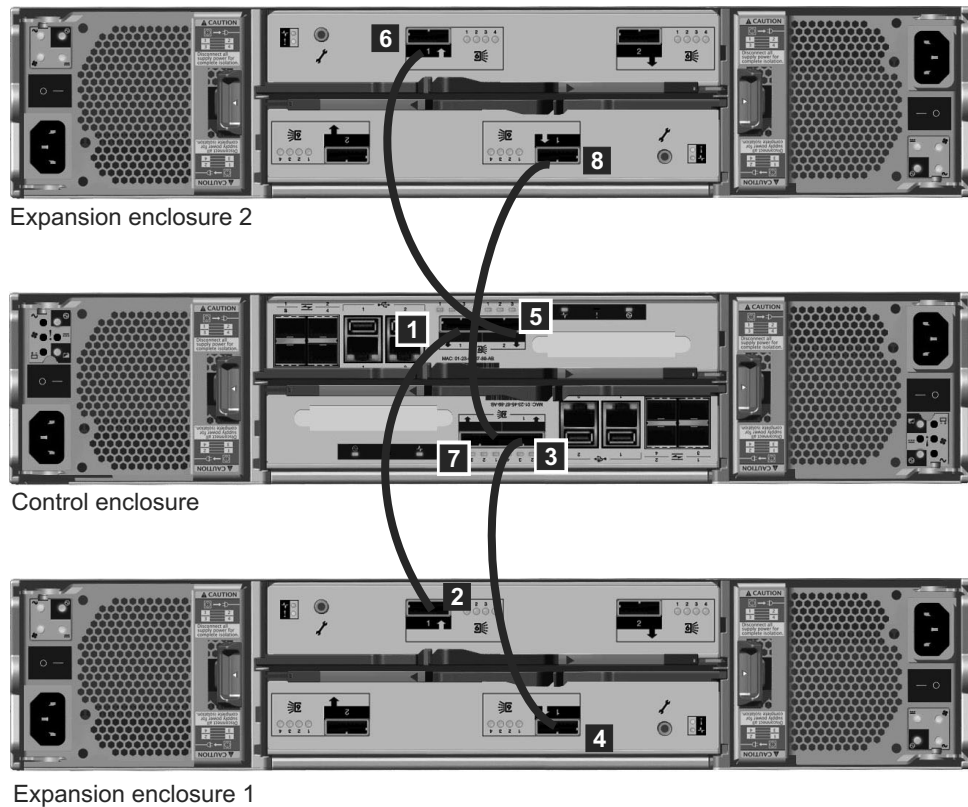

Figure 33. Adding a second expansion enclosure

- a. Port 2 **5** of the upper canister, control enclosure, attaches to Port 1 **6** of the upper canister, expansion enclosure 2.
- b. Port 2 **7** of the lower canister, control enclosure, attaches to Port 1 **8** of the lower canister, expansion enclosure 2. The port locations on the lower canister are inverted from the port locations on the upper canister. Port 1 on the lower canister is opposite port 1 on the upper canister.

**Note:** The connecting sequence from port 2 of the node canister is called chain 2.

4. Attach the SAS cables from the first expansion enclosure to the third expansion enclosure.



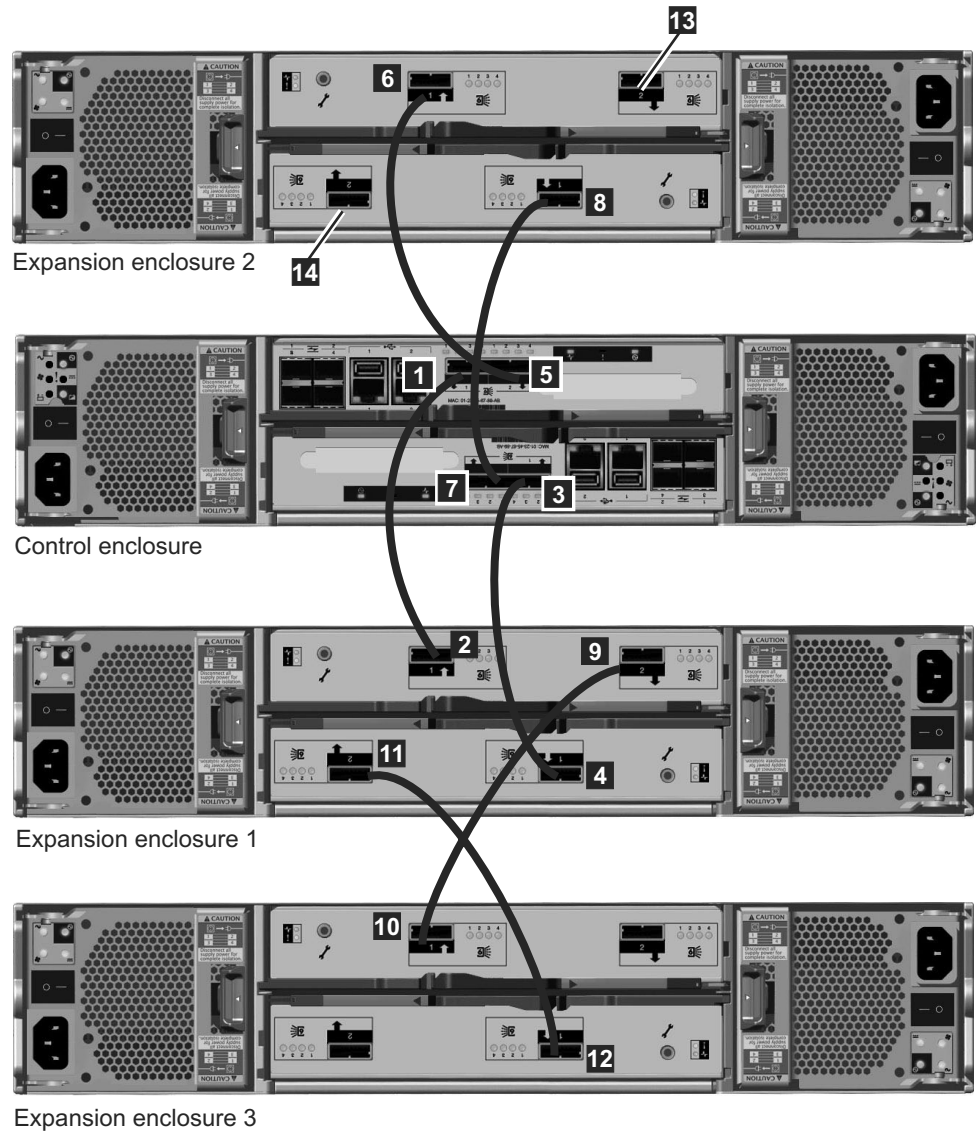

Figure 34. Attaching SAS cables to the enclosures

- a. Port 2 **9** of the upper canister, expansion enclosure 1, attaches to Port 1 **10** of the upper canister, expansion enclosure 3.
- b. Port 2 **11** of the lower canister, expansion enclosure 1, attaches to Port 1 **12** of the lower canister, expansion enclosure 3.
5. Attach SAS cables for additional expansion enclosures. You can add up to nine expansion enclosures. You add a fourth expansion enclosure at **13** and **14** on expansion enclosure 2.
  - a. Add the enclosures alternately to chain 1, and then chain 2.
  - b. Use port 2 on the canisters that are already connected to attach to port 1 on the canisters of the enclosures that you want to add.
6. Verify your cabling.

## Step 10. Attaching the Ethernet cables

This task guides you through connecting both the internal and external Ethernet connections for your system.

This task assumes that your initial planning has determined where the Ethernet cables are to be located. The Storwize V7000 Unified control enclosure requires at least one and a maximum of two 1 Gbps Ethernet connections. Refer to Figure 35, Figure 36 on page 33, and Table 3 on page 33. For the file modules, the first two 1 Gbps Ethernet ports labelled **1** and **2** in Figure 37 on page 34 are used for internal communications between the file modules. The third and fourth 1 Gbps Ethernet ports are used for management and data (if needed). All 10 Gbps Ethernet ports are dedicated to data. Management cannot be performed over the 10 Gbps Ethernet. Refer to Figure 37 on page 34 and Table 4 on page 34.

**Note:** It is important that the file modules are able to communicate over the network with the Storwize V7000 control enclosure for management, service and optional file access.

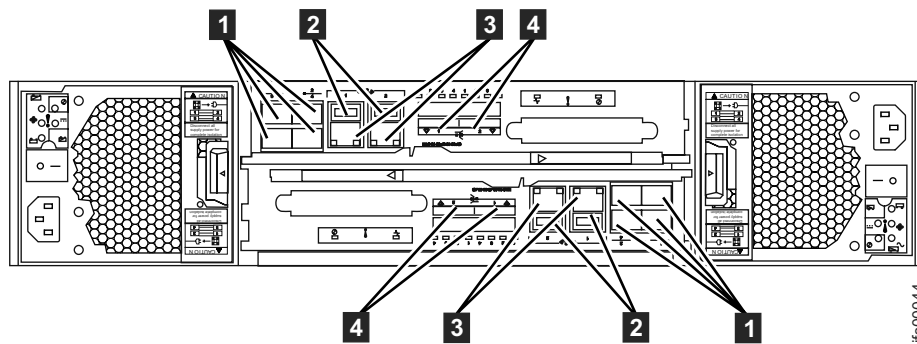
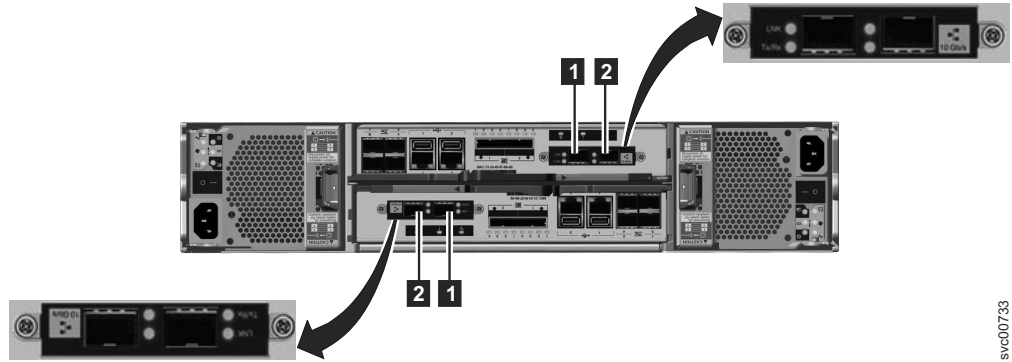

Figure 35. Control enclosure Ethernet network connections.

- **1** Fibre Channel ports (8 Gbps). Each canister has four Fibre Channel ports. They are in a block of four in two rows of two connectors. The ports are numbered 1 - 4 from left to right, top to bottom. Two ports connect to the file modules and two are connected to the SAN.
- **2** USB ports. Each canister has two USB ports. The ports are side by side on the canister and are numbered 1 on the left and 2 on the right. One port is used during installation.
- **3** Ethernet ports (1 Gbps). Each canister has two Ethernet ports. The ports are side by side on the canister. They are numbered 1 on the left and 2 on the right on the upper canister. The port locations are inverted for the lower canister. Port 1 must be connected first; the use of port 2 is optional.
- **4** Serial-attached SCSI (SAS) ports (6 Gbps). Each canister has two SAS ports. The ports are side by side on the canister. They are numbered 1 on the left and 2 on the right. Port 1 must be connected first if you are adding one expansion enclosure. Port 2 must be connected if you are adding a second expansion enclosure.



sv000733

Figure 36. 10 Gbps Ethernet ports on the rear of the Storwize V7000 enclosure

- **1** 10 Gbps Ethernet port 3 which is the left port.
- **2** 10 Gbps Ethernet port 4 which is the right port.

Table 3. Ethernet connections available with the control enclosure

Item	Port	Purpose	IP address is assigned by InitTool	Use
<b>3</b> (left port, Figure 35 on page 32)	Built-in Ethernet port 1	1 Gbps external network connection	Yes	Management and service port for each canister, optional iSCSI. (The Storwize V7000 control enclosure must be able to communicate over the network with the file modules.)
<b>3</b> (right port Figure 35 on page 32)	Built-in Ethernet port 2	1 Gbps external network connection	No	Optional management and service port, optional iSCSI
<b>1</b> (Figure 36)	Ethernet port 3 on a 2076-312 or 2076-324	10 GbE external network connection	No	Optional iSCSI
<b>2</b> (Figure 36)	Ethernet port 4 on a 2076-312 or 2076-324	10 GbE external network connection	No	Optional iSCSI

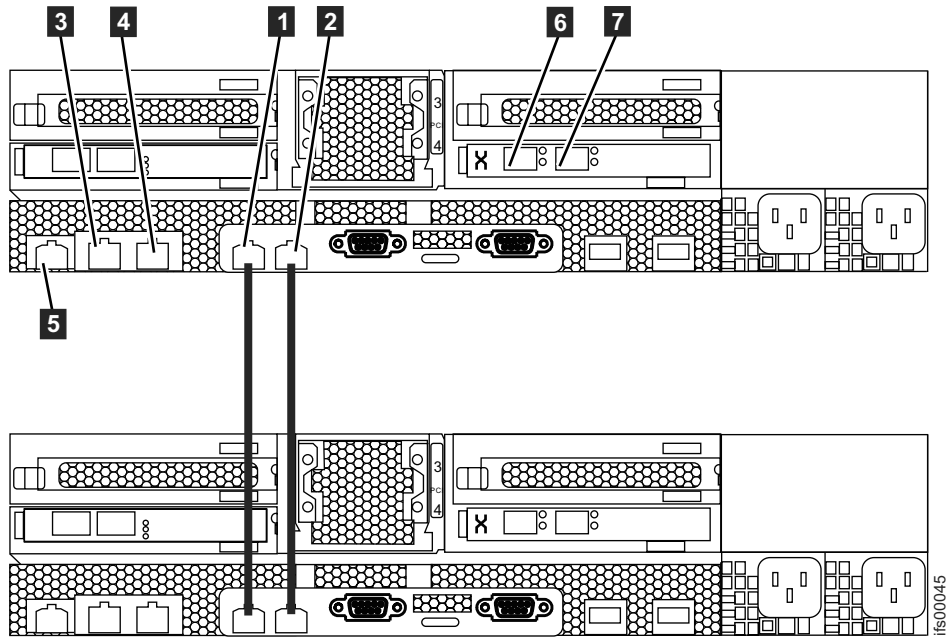

Figure 37. File module node Ethernet network connections.

Table 4. Ethernet connections available with the file modules

Item	Port	Purpose	IP address is assigned by InitTool	Use
<b>1</b>	Built-in Ethernet port 2	1 Gbps file module to file module interconnect	From the range	File module to file module configuration mirroring
<b>2</b>	Built-in Ethernet port 1	1 Gbps file module to file module interconnect	From the range	File module to file module configuration mirroring
<b>3</b>	Built-in Ethernet port 3	1 Gbps external network connection	Yes	Management, service and optional file access. (The file modules must be able to communicate over the network with the Storwize V7000 control enclosure.)
<b>4</b>	Built-in Ethernet port 4	1 Gbps external network connection	No	Optional management, optional service, optional file access

Table 4. Ethernet connections available with the file modules (continued)

Item	Port	Purpose	IP address is assigned by InitTool	Use
5	IMM Ethernet port	Ethernet link to the system X Integrated Management Module	No	Not supported
6	PCI slot 4, port 1	10 GbE external network connection	No	Optional file access
7	PCI slot 4, port 0	10 GbE external network connection	No	Optional file access

**Attention:** The default service IP addresses on your new Storwize V7000 Unified control enclosure might conflict with existing devices that are attached to the network or with other new control enclosures that you are installing. The service IP address 192.168.70.121 subnet mask 255.255.255.0 is preconfigured on Ethernet port 1 of the upper canister, canister 1. The service IP address 192.168.70.122 subnet mask 255.255.255.0 is preconfigured on Ethernet port 2 of the lower canister, canister 2.

If you encounter that situation, change the service IP addresses on the new nodes before connecting the Ethernet cables. For details, see “Initialize the Storwize V7000” on page 45 or see the *Storwize V7000 Unified Problem Determination Guide* PDF on the DVD for further information about setting service IP addresses using a USB key.

Perform the following steps:

1. For each node canister in the control enclosure, connect an Ethernet cable between Ethernet port 1 of the canister and the Ethernet network.

**Note:** Ethernet cables are not supplied as part of your order. A CAT 5 unshielded twisted pair (UTP) is the minimum requirement for an Ethernet cable.

Ensure that cables are installed in a tidy manner to reduce the risk of cable damage.

2. Optionally attach Ethernet cables between Ethernet port 2 on each node canister and your Ethernet network.

**File module to file module:**

- Connect an Ethernet cable from Ethernet port 1 on the first file module to the first Ethernet port on the second file module. Refer to Figure 37 on page 34 for port locations.

**Note:** Ethernet cables for the internal network are provided by IBM with the file modules.

- Connect an Ethernet cable from Ethernet port 2 on first file module to Ethernet port 2 on the second file module.
- Route the Ethernet cables through the cable management arms, and secure any excess using the cable retention features of the rack.

### File module management ports:

- Connect an Ethernet cable from Ethernet port 3 on the first file module to an Ethernet network. If using two Ethernet cables (as recommended), connect another Ethernet network cable to Ethernet port 4. When using only one Ethernet port, the network status is marked as degraded and an associated warning event is listed in the health center.
- Repeat the previous step for the second file module.
- Route the Ethernet cables through the cable management arm, and secure any excess using the cable retention features of the rack.

### File modules to external (host ports) network (10 GB Fibre Ethernet):

You have two 10 Gbps Fibre Ethernet ports available for host connections from each file module. The ports are on the PCI card located in slot 4. Connect your network cables to the Ethernet ports in these slots as applicable. Refer to Figure 37 on page 34.

---

## Step 11. Attaching the Fibre Channel cables

### File modules:

To attach the Fibre Channel cables, perform the following steps:

- Connect two Fibre Channel cables from the first file module to the control enclosure (refer to Table 5). Be sure to plug one cable into one node canister on the control enclosure and the other cable into the other node canister for redundancy. Route the Fibre Channel cables through the Cable Management Arms.

**Note:** Fibre Channel cables are provided by IBM with the file modules.

- Repeat the previous step for the other file module.
- Before continuing, make sure that you have connected the Fibre Channel cabling as shown in Figure 38 on page 37 to ensure proper redundancy. Incorrect cabling may result in a loss of service during system maintenance procedures.
- Secure any excess cable length using the cable retention features of the rack.

*Table 5. How to connect Fibre Channel cables from file modules to the control enclosure. Refer to the graphic below.*

File module	Control enclosure
<b>A</b> File module 1 (usually lower in the rack)	<b>C</b> Control enclosure
<b>2</b> Fibre Channel slot 2, port 1	<b>5</b> Upper canister Fibre Channel port 1
<b>1</b> Fibre Channel slot 2, port 2	<b>8</b> Lower canister Fibre Channel port 1
<b>B</b> File module 2 (usually upper in the rack)	<b>C</b> Control enclosure
<b>4</b> Fibre Channel slot 2, port 1	<b>6</b> Upper canister Fibre Channel port 2
<b>3</b> Fibre Channel slot 2, port 2	<b>7</b> Lower canister Fibre Channel port 2

**Note:** After the blue indicator light appears when the file modules are powered on, the amber LED (with the number 8 stamped on the metal next to each Fibre Channel port) should be lit to show that the link speed is 8 Gbps.

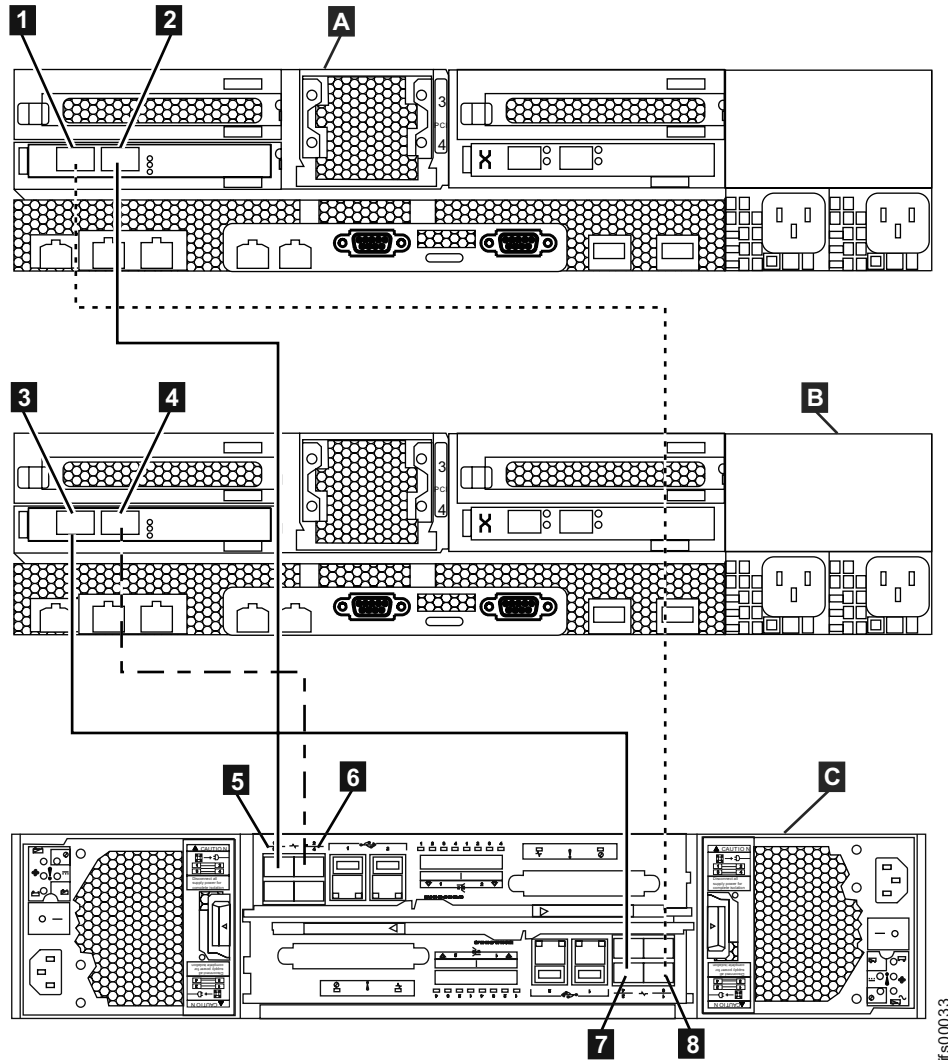

Figure 38. Diagram showing how to connect the file modules to the control enclosure using Fibre Channel cables. Refer to previous table.

**Note:** If you are using the Storwize V7000 Unified for remote copy or block I/O, connect the Fibre cables to the remaining controller canisters Fibre channel ports 3 and 4.

## Step 12. Connecting the power cords

### Control enclosure:

Two power supply units are located in each enclosure. Ensure that the power switches for the control enclosure and expansion enclosures power supply unit are switched off.

**Note:** Each power supply unit comes with an attached cable retention bracket that fastens around the power cord to prevent the cord from being removed accidentally.

Perform the following steps when you attach the power cord to each power supply unit:



1. Straighten the cable tie on the cable retention bracket. The cable retention bracket is attached to the power supply unit.
2. Open the cable retention bracket.



*Figure 39. Unlocking the cable retention bracket*

3. Slide the cable retention bracket away from the power supply unit until there is enough room to attach the cable retention bracket to the cable. When sliding the bracket away from the cable plug-in, pull the lever on the bracket that controls the cable tie slightly towards the center of the canister. You do not need to pull the lever to slide the bracket towards the cable plug-in.
4. Attach a power cord to each of the two power supply units in each enclosure. Ensure that cables are installed in a tidy manner to reduce the risk of cable damage when Storwize V7000 Unified replaceable units are removed or inserted.
5. Place the cable retention bracket around the end of the cable that plugs into the power supply unit.
6. Slide the cable retention bracket along the cord until it fits snugly against the plug end of the cable.



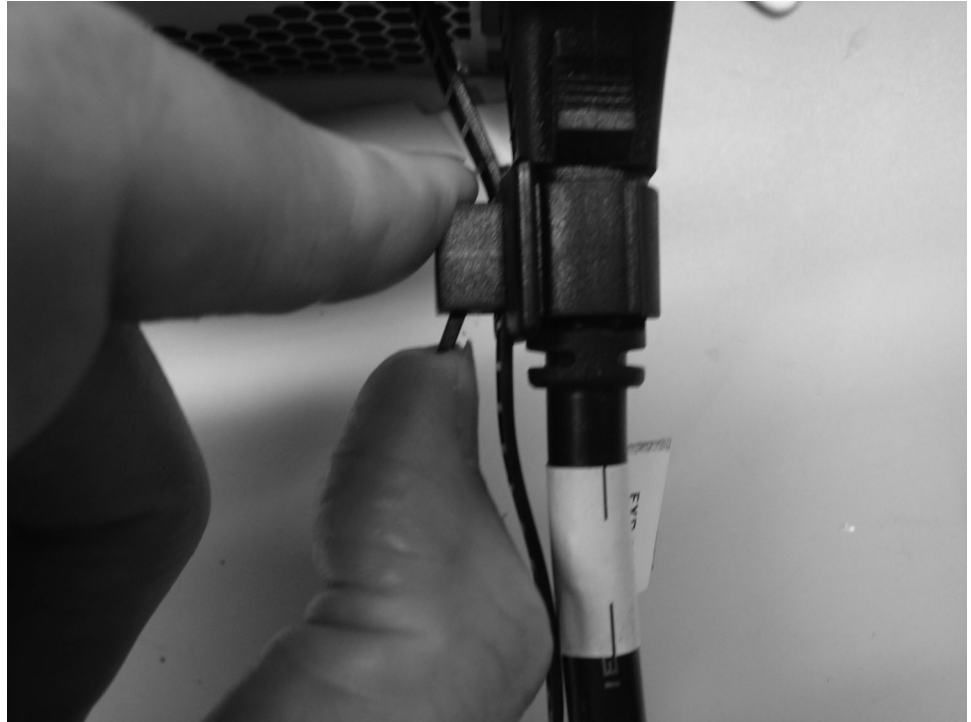

Figure 40. Sliding the cable retention bracket directly behind the power cord

7. Tighten the fastener around the plug.
8. Repeat the steps for each additional power cord.
9. Plug the power cords into a properly grounded electrical outlet. To provide power failure redundancy, plug the power cords for the individual power supply units for each enclosure into separate power distribution units, if possible.

#### **File modules:**

Perform the following steps when you attach the power cord to each power supply unit:

1. Connect two power cords from a file module rack power supply. Plugging them into separate Power Distribution Units (PDUs) is recommended for redundancy. Route the power cords through the Cable Management Arms.
2. Repeat the previous step for the other file module.
3. Secure any excess cable length using the cable retention features of the rack.

---

## **Step 13. Powering the system on and off**

Follow the procedures for powering on the expansion enclosure and file modules, and in the order specified.

**Attention:** Do not operate the system when the drive assemblies are missing. Drive assemblies that are missing disrupt the airflow; the drives do not receive sufficient cooling. You must insert blank carriers into unused drive bays.

#### **Powering on an expansion enclosure:**

1. Power on the newly installed enclosures. Use the power switch on each of the two power supply units in the back of the expansion enclosure.
2. Use the information in Table 7 on page 41 to verify the state of the light emitting diodes (LEDs) on the system. Verify that no faults are detected. See the *Storwize V7000 Unified Problem Determination Guide* PDF on the CD if problems are encountered.

Both Figure 41 and Figure 42 show the location of the LEDs on the power supply units, located at the front of the expansion enclosure. Figure 43 on page 41 shows the location of the LEDs on the power supply units, located at the rear of the expansion enclosure. The LEDs are located at position **1**.



Figure 41. 24 drives and two end caps

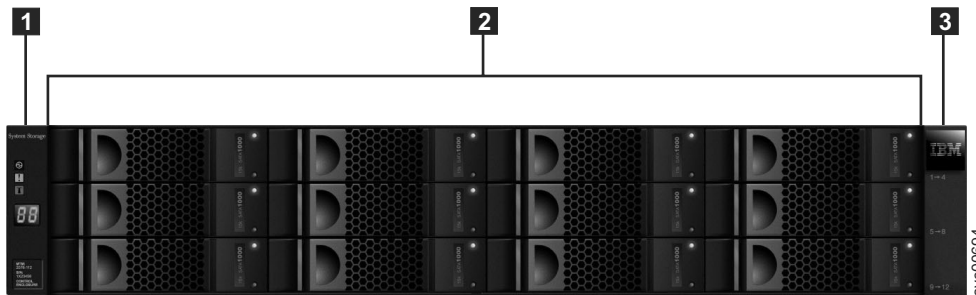





Figure 42. 12 drives and two end caps

Table 6. LED status front of control enclosure or expansion enclosure. Refers to item [1] in the figures above.

Hardware component	LED name and symbol	If power on and no fault is detected
Left enclosure end cap, front of enclosure	Power, top 	LED is on.
	Fault, middle 	LED is off.
	Identify, bottom 	LED is off.

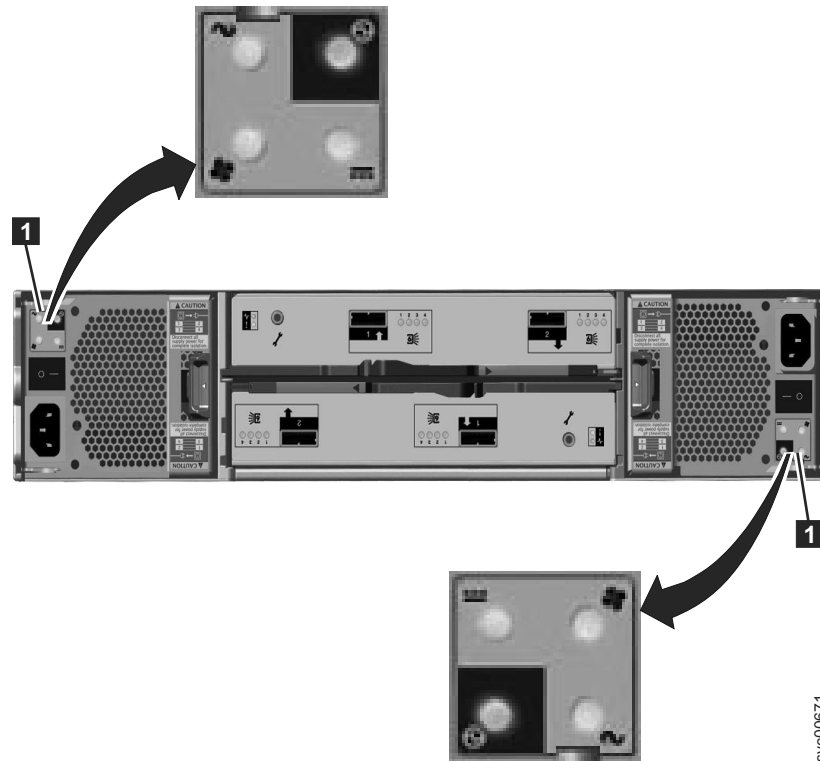







Figure 43. LEDs on the power supply units of the expansion enclosure

Table 7. LED status rear of expansion enclosure.

Hardware component	LED name and symbol	If power on and no fault is detected
Expansion canister, rear. The reference to the top and bottom locations applies to canister 1, which is the upper canister. The LED locations are inverted for canister 2, which is the lower canister.	Canister status, top 	LED is on.
	Fault status, bottom 	LED is off.
	SAS ports	When a SAS port is functioning correctly, all four green LEDs above the port are on. If no cable is plugged into the port, or if the canister at either end of the cable is not yet fully started, the LEDs are not on.
Power supply unit, expansion enclosure. The reference to the left and right locations applies to power supply unit 1, which is the left power supply. The LED locations are inverted for power supply unit 2, which is the right power supply.	Power supply, upper right 	LED is on.
	Fan failure 	LED is off.
	dc power failure 	LED is off.
	ac power failure 	LED is off.

**Powering on a control enclosure:**

1. Power on the control enclosure, if it is not already powered on and configured. Use the power switch on each of the two power supply units, located in the back of the enclosure.
2. Use Table 8 to verify the state of the LEDs on the system. Verify that no faults are detected.

Figure 44 shows the location of the LEDs on the power supply units in the rear of the control enclosure.

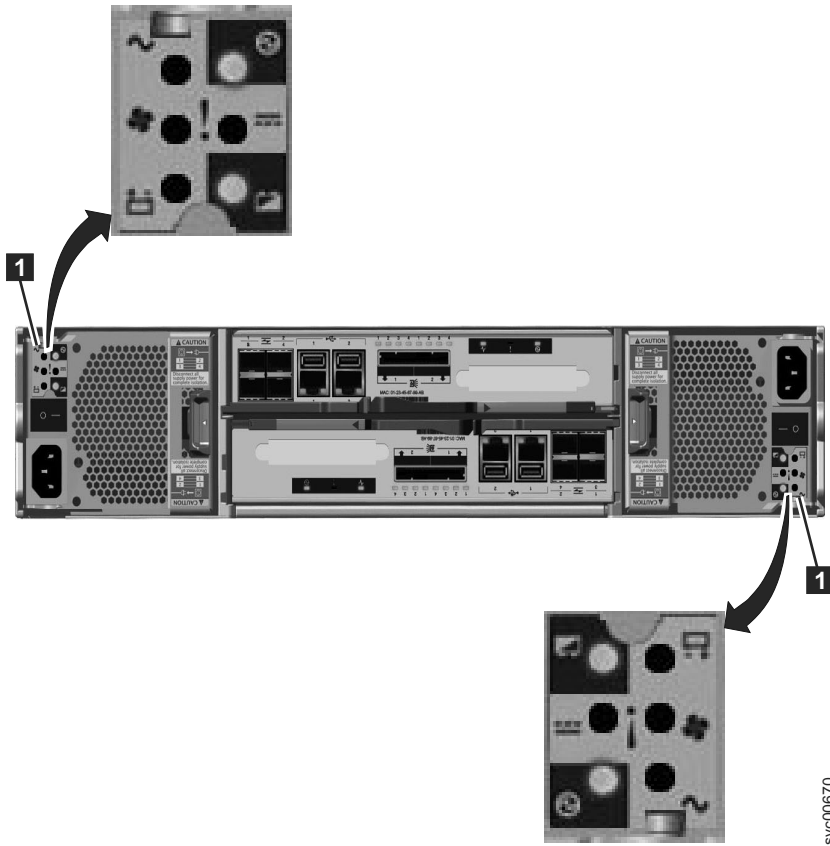











Figure 44. LEDs on the power supply units of the control enclosure

Table 8. LED status when control enclosure is powered on

Hardware component	LED name	If power on and no fault is detected
Left enclosure end cap, front of enclosure	Power, top ⏻	LED is on.
	Fault, middle !	LED is off.
	Identify, bottom 📡	LED is off.

Table 8. LED status when control enclosure is powered on (continued)

Hardware component	LED name	If power on and no fault is detected
Node canister, rear. The reference to the top and bottom locations applies to canister 1, which is the upper canister. The LED locations are inverted for canister 2, which is the lower canister.	Fibre Channel port	If the Fibre Channel port is used: One or more LEDs are on or flashing per port. The LEDs are located between the Fibre Channel ports. The arrow-shaped LEDs point toward the affected port.
	Ethernet port, if used	One or more LEDs are on per port.
	SAS ports	When a SAS port is functioning correctly, all four green LEDs above the port are on. If no cable is plugged into the port, or if the canister at either end of the cable is not yet fully started, the LEDs are not on.
	System status, left 	LED is flashing or on. The status is on if the node canister is an active member of a clustered system. The LED is flashing if the node canister is in service or candidate state. If the LED is off, the node canister might still be booting up. Wait up to 5 minutes for the node canister to complete booting up.
	Fault status, middle 	LED is off.
	Power status, right 	LED is on.
Power supply unit, control enclosure. The reference to the left and right locations applies to power supply unit 1, which is the left power supply. The LED locations are inverted for power supply unit 2, which is the right power supply.	Power supply, upper right 	LED is on.
	ac power failure 	LED is off.
	dc power failure 	LED is off.
	Fan failure 	LED is off.
	Battery failure 	LED is off
	Battery good, lower right 	LED is on or flashing.

**Attention:** Do not go to the next section until the LEDs are in the required states. If any error lights are displayed, see the *Storwize V7000 Unified Problem Determination Guide* documentation CD for more information about light path issues.

See the *IBM Storwize V7000 Troubleshooting, Recovery, and Maintenance Guide* PDF on the CD if problems are encountered.

## File module power features:

When the file module is connected to a power source but is not turned on, the operating system does not run, and all core logic except for the integrated management module is shut down. However, the file module can respond to requests from the integrated management module, such as a remote request to turn on the file module. The power-on LED flashes to indicate that the file module is connected to power but is not turned on. The power on LED is found in the front of the file module.

### Powering on the file module

Approximately 3 minutes after the file module is connected to power, the power-control button becomes active. Also, one or more fans might start running to provide cooling while the file module is connected to power. You can turn on the file module and start the operating system by pressing and releasing the power on button. The power on button is located at the front of the file module.

### Turning off the file module

When you turn off the file module and leave it connected to power, the file module can respond to requests from the integrated management module. For example, it can respond to a remote request to turn on the file module. While the file module remains connected to power, one or more fans might continue to run. To remove all power from the file module, you must disconnect it from the power source.

**Important:** To view the error LEDs on the system board, leave the file module connected to a power source.

Some operating systems require an orderly shutdown before you turn off the file module. See your operating-system documentation for information about shutting down the operating system.

### CAUTION:

The power on button on the device does not turn off the electrical current supplied to the device. The device also might have more than one power cord. To remove all electrical current from the device, ensure that all power cords are disconnected from the power source.

Press and release the power on button to start an orderly shutdown of the operating system and turn off the file module, if your operating system supports this feature

**Attention:** If you have a problem powering off the system, see the *Storwize V7000 Unified Problem Determination Guide* documentation CD for more information about light path issues.

---

## Chapter 3. Configuring the system

This document helps you set up your system for the first time.

### Setting up your system for the first time:

Before you begin, make sure your system is properly cabled for the Storwize V7000 Unified system and any expansion enclosures. Refer to the cabling sections listed under Chapter 2, “Performing the hardware installation,” on page 13. The following guides you through setting up your system for the first time. The process includes the following key steps:

- Initialize the Storwize V7000
- Initialize the file modules
- Configure the software
- Check the Storwize V7000 Unified system status
- Upgrade the Storwize V7000 Unified software
- Problems with initial configuration
- Enable IBM Tivoli Assist On-Site (AOS)

---

### Initialize the Storwize V7000

This document guides you through setting up the control enclosure.

The following Information is required before configuring your system. Fill in all the information needed in the **Value** column before proceeding with this installation.

**Note:** You cannot use VLAN-based subnets to configure the system network. To configure the Storwize V7000 Unified file module management IP address, file module 1 and 2 IP addresses, subnet mask, and gateway address, you must provide non-VLAN based network information. After the system is configured, use the **chnwmgmt** command to change the Storwize V7000 Unified network settings to switch to a VLAN-based subnet. This recreates the network with a VLAN-based subnet.

*Table 9. The following Information is required before configuring your system. Fill in all the information needed in the Value column before proceeding with this installation.*

Field	Value	Notes
Storwize V7000 IP address		IP address for the Storwize V7000 system (such as 9.21.22.xxx)
Storwize V7000 subnet mask		Subnet for the above Storwize V7000 address (such as 255.255.255.0)
Storwize V7000 gateway address		Gateway for Storwize V7000 address to user network (such as 9.21.22.1)

Table 9. The following Information is required before configuring your system. Fill in all the information needed in the Value column before proceeding with this installation. (continued)

Field	Value	Notes
Internal IP address range		<p>The internal IP addresses are for internal communication among the Storwize V7000 Unified components for management and maintenance. Select one of the IP address ranges listed below. The range you select must not conflict with the IP addresses used for the customer Ethernet connections to the management nodes or interface nodes. The available IP address ranges are:</p> <ol style="list-style-type: none"> <li>172.31.*.*</li> <li>192.168.*.*</li> <li>10.254.*.*</li> </ol> <p><b>Important:</b></p> <ol style="list-style-type: none"> <li>If the customer network does not use IP addresses in the 172.31.*.* range then select range 1.</li> <li>If the customer network uses IP addresses in the 172.31.*.* range, but does not use IP addresses in the 192.168.*.* range, then select range 2.</li> <li>If the customer network uses IP addresses in the 172.31.*.* range and the 192.168.*.* range, but does not use IP addresses in the 10.254.*.* range, then select range 3.</li> </ol>
File module management IP address		Designated customer management IP for file module
File module 1 IP address		The service access IP address assigned to file module 1
File module 2 IP address		The service access IP address assigned to file module 2
Network Time Protocol (NTP) server		Site NTP server address
Alternate NTP server		Alternate NTP server, if applicable

1. Locate the USB key that was shipped with your order in the documentation package.



**Note:** You might encounter a problem where the code cannot be run if you use your own USB key. The USB key that you use must:

- Contain a FAT32 formatted file system on its first partition. NTFS and other file system types are not supported.
- Contain a copy of the Microsoft Windows USB key `InitTool.exe` executable that is located in the root directory of the file system.
- Be write enabled.

2. Insert the USB key into a USB port in a personal computer that is running Microsoft Windows XP Professional or higher.

If the system is configured to autorun for USB keys, the initialization tool starts automatically. Otherwise, open the USB key from **My Computer** and double-click the `InitTool.exe`.

**Note:** If you are running a non-Windows operating system, skip to 4 on page 48.

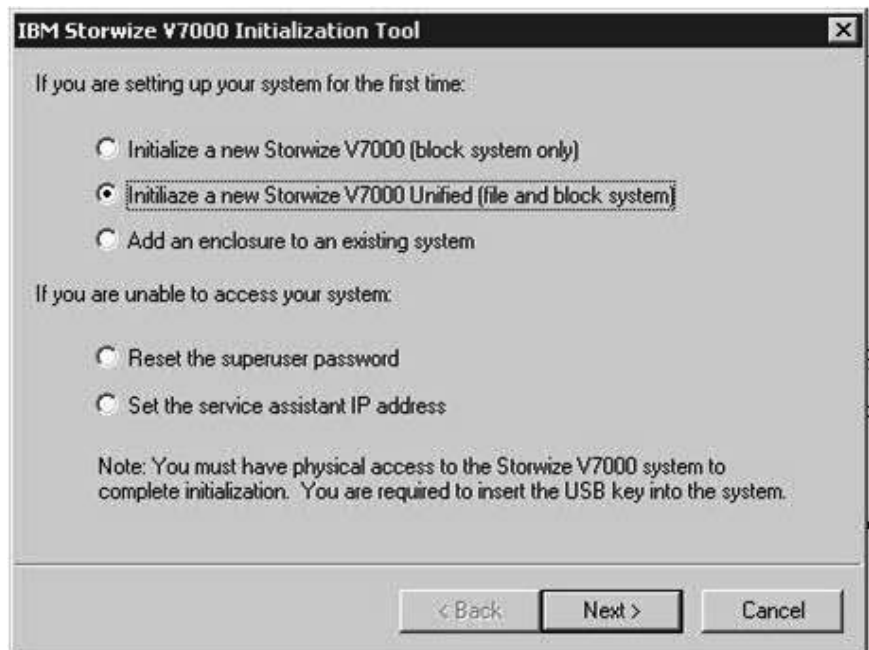

Figure 45. Initialization tool welcome panel

3. Select the **Initialize a new Storwize V7000 Unified (file and block system)** option from the Welcome panel of the initialization tool. Click **Next**. Use the initialization tool to complete the following steps:

**Note:** See Table 1 for details on IP addresses that are used in these steps.

- a. Enter the Storwize V7000 system IP, netmask IP, and gateway IP addresses. Click **Next**.
- b. Enter the **Management IP**, **Storwize V7000 File Module 1**, and **Storwize V7000 File Module 2** IP addresses. Then select **10.254.0.1-10.254.0.4** (or one of the other address ranges depending on your network configuration) for the default internal network IP scheme. Click **Next**.
- c. Click **Finish** on the Final Page and make sure that both the `satask.txt` and the `cfgtask.txt` file are on the USB key. If the files are not on the USB key refer to *Storwize V7000 Unified Problem Determination Guide* PDF on the DVD.

- d. Proceed to 5.
4. If you are running a non-Windows operating system, you must create the files manually on the USB key.

*Table 10. Create two files and enter one line each, adjusted to the values fitting to your environment. Refer to Table 9 on page 45 for the command content to the appropriate addresses.*

Filename	Content
satask.txt	<pre>satask mknascluster -clusterip 9.111.160.10 -mask 255.255.248.0 -gw 9.111.167.254 -consoleip 9.111.160.50</pre> <p>Where:</p> <ul style="list-style-type: none"> <li>• clusterip = Storwize V7000 IP address</li> <li>• mask = Storwize V7000 subnet mask</li> <li>• gw = Storwize V7000 gateway address</li> <li>• consoleip = File module management IP address</li> </ul>
cfgtask.txt	<pre>cfginit --ip=9.111.160.50 --netmask=255.255.248.0 --gateway=9.111.167.254 --serviceip1=9.111.160.51 --serviceip2=9.111.160.52 --internalips=10.254.0.1 --storwizeip=9.111.160.10</pre> <p>Where:</p> <ul style="list-style-type: none"> <li>• ip = File module management IP address</li> <li>• netmask = Storwize V7000 subnet mask</li> <li>• gateway = Storwize V7000 gateway address</li> <li>• serviceip1 = File module 1 IP address</li> <li>• serviceip2 = File module 2 IP address</li> <li>• internalips = Internal IP address range</li> <li>• storwizeip = Storwize V7000 IP address</li> </ul>

5. Continue after the Storwize V7000 control enclosure has completed booting. You can verify this by checking that the power LED is solid green and the status LED is blinking green on each of the node canisters. Insert the USB key into either USB connector (located at the back of the Storwize V7000 control enclosure) on the upper canister (node 1). While the clustered system is being created, the red/amber fault LED, on the node canister flashes (the middle light, at the rear of the unit designated by the !). When the red/amber fault LED stops flashing, proceed to “Initialize the file modules.”

---

## Initialize the file modules

To initialize the file modules follow these procedures.

1. Verify that the blue LEDs at the front of the file modules are flashing. If both are flashing, go to step 2 now. Do not insert the USB key unless both file modules blue LEDs are flashing. If both LEDs are not flashing, allow at least 30 minutes for a full boot cycle. If both LEDs are still not flashing, reboot the file module that is not flashing and allow 30 minutes for a boot cycle. Continue with step 2 once both LEDs are flashing. If the problem persists, call support.
2. Insert the USB key that was used to configure the Storwize V7000 control enclosure into file module 1 (the lower of the two file modules). Use any of the file module's USB ports.
3. The following sequence should occur:

- a. The LED on the local node (where the USB key is inserted) changes to solid blue (while the partner node LED continues flashing blue).
  - b. The partner node LED turns to solid blue (can take up to 5 minutes). The partner node's LED may start flashing again for several minutes before turning off at completion. Also, if the code on the other node or the control enclosure is down level, it automatically updates at this time. **This process can take up to 2 hours.**
  - c. As long as the LED remains solid blue on the file module where the USB key is inserted, then the configuration process is still ongoing. If it starts blinking again the process has failed, remove the USB key and go to 5 to check for errors.
  - d. The local node LED turns off.
4. When the blue LEDs on both file modules turn off, the initial configuration has completed, then remove the USB key. If both blue LEDs fail to turn off in 2 hours, go to step 5.
  5. To see if the installation process was successful, insert the USB key back into a laptop or desktop or server. The initialization tool should start automatically, if not, then start it manually.
  6. A message displays showing that the installation was successful or that it has failed. If it failed then an error code is provided. Look for this error code in the *Storwize V7000 Unified Problem Determination Guide* (PDF on the CD), under **Installation error codes**. This will show you what action to take.
  7. When you are finished using the USB key, store it in a safe location. You may need to use it for other tasks.

---

## Configure the software

Configure the software following these procedures.

### Required information:

Fill out all the information in the following tables in order to navigate through the Easy Setup wizard configuration:

*Table 11. This table (optional) is useful for completing the Easy Setup wizard. The table entries serve as a guide only. Enter the Value column with your system information.*

Field	Value	Notes
System name		The name associated with the Storwize V7000 Unified IP address (such as storwizeV7000)
NetBIOS name		Name associated with the file module management address (for example, filemod1) <b>Note:</b> To change the NetBIOS name after the initial configuration, use the <b>cfgcluster</b> CLI command.
Time zone		Refer to <b>Time Zone List</b> in the IBM Storwize V7000 Unified Information Center. Example: If the machine is being installed in Tucson, Arizona, USA, the best match for the time zone is America/Phoenix. You will match this to a drop down menu located in the Easy Setup Wizard.
Network Time Protocol (NTP) Server		Site NTP server address

Table 11. This table (optional) is useful for completing the Easy Setup wizard. The table entries serve as a guide only. Enter the Value column with your system information. (continued)

Field	Value	Notes
Alternate NTP server		Alternate NTP server if applicable
VLAN ID		Optional. This list shows one or more Virtual LAN Identifiers. A VLAN ID must be in the range from 2 to 4095. If you do not use VLANs then leave this field blank. Restriction: VLAN 1 is not supported for Scale Out Network Attached Storage client traffic. This restriction is intended to prevent security exposure and reduce the probability of network configuration errors. VLAN 1 is used within the industry as the default or native VLAN. Many vendors use VLAN ID value 1 for management traffic by default. Configuring VLAN 1 as available within the network can be a security exposure because VLAN 1 might span large parts of the switched network by default. Setting VLAN 1 for user client traffic can require explicit steps that differ by vendor and can be prone to configuration error.
Domain name		This name is the public network domain name. Example: customer.com The Cluster Name and Domain Name are typically used in combination. Example: cluster1.customer.com
DNS servers		Numerical address of user Domain Name Server (for example, 9.11.22.xxx) can be multiple server addresses
DNS search domain		Additional domain names to be used with primary domain name (for example, a.customer.com or us.customer.com)
Authentication		Refer to Table 15 on page 54, Table 16 on page 54, Table 17 on page 56, Table 18 on page 57 to set up your authentication method. When done, return here to continue.
Subnet		Where subnet is the numeric IP address of the public network (data path). It is used for all of the Ethernet data path connections. <b>Note:</b> The Subnet is entered as the subnet address followed by the CIDR equivalent of the subnet mask (for example 9.11.100.100/32).
Subnet mask		This is the subnet mask associated with the previous IP address.
CIDR equivalent of the subnet mask		This is the CIDR (/XX) equivalent of the subnet mask that was specified previously. Look up the subnet mask (specified previously) then refer to the Table 14 on page 53 and find the CIDR equivalent and record it on this line. It must be between /0 and /32.

Table 11. This table (optional) is useful for completing the Easy Setup wizard. The table entries serve as a guide only. Enter the Value column with your system information. (continued)

Field	Value	Notes
VLAN ID		Optional. This list shows one or more virtual LAN Identifiers. A VLAN ID must be in the range from 2 to 4095. If you do not use VLANs then leave this field blank. Restriction: VLAN 1 is not supported for Scale Out Network Attached Storage client traffic. This restriction is intended to prevent security exposure and reduce the probability of network configuration errors. VLAN 1 is used within the industry as the default or native VLAN. Many vendors use VLAN ID value 1 for management traffic by default. Configuring VLAN 1 as available within the network can be a security exposure because VLAN 1 might span large parts of the switched network by default. Setting VLAN 1 for user client traffic can require explicit steps that differ by vendor and can be prone to configuration error.
Default gateway		This is the numeric gateway of the data path connection to the customer network. It is used for all of the Ethernet data path connections on a single file module.
Public IP addresses		The public IP addresses are the data path connections to the customer network. They are used for all of the Ethernet data path connections the file modules. At least 2 addresses are recommended (1 per node). The data path connections use Ethernet bonding, so a single IP address (along with a subnet mask and gateway) is used for all available Ethernet ports on a single file module. The system automatically load balances between the physical ports on a single file module.
Additional gateways		Additional gateways are the data path connection to the customer network. It is used for all of the Ethernet data path connections on a single 2851-SI1 file module
Internal IP address range		Select one of the following IP address ranges. The range you select must not conflict with the IP addresses used for the user Ethernet connections to the file module management nodes. The available IP address ranges are: 1. 172.31.*.* 2. 192.168.*.* 3. 10.254.*.* Note: 1. If the network does NOT use IP addresses in the 172.31.*.* range then select range 1. 2. If the network uses IP addresses in the 172.31.*.* range, but does not use IP addresses in the 192.168.*.* range, then select range 2. 3. If the network uses IP addresses in the 172.31.*.* range and the 192.168.*.* range, but does not use IP addresses in the 10.254.*.* range, then select range 3.
Email server IP address		User internal email server

Table 12. Remote support information

Field	Value	Note
Company Name		
Address		This is the address where the machines are located. Example: Bldg. 123, Room 456, 789 N Data Center Rd, City, State
Customer Contact Phone Number		This is the primary phone number that IBM service calls if the system calls home to report a problem.
Off Shift Customer Contact Phone Number		This is the alternate phone number that IBM service calls if the system calls home to report a problem.
IP ADDRESS OF PROXY SERVER (FOR CALL HOME)	_____	Optional. If a proxy server is needed to access the internet for Call Home, this is the IP address of that server. If no proxy server is used, leave this field blank.
Port Of Proxy Server (For Call Home)		Optional. If a proxy server is needed, this is the port corresponding to the IP address listed previously. If no proxy server is used, leave this field blank.
Userid For Proxy Server (For Call Home)		Optional. If a proxy server is needed, and the proxy server requires a user ID and password, record the user ID here. If no proxy server is used, or no user ID and password are used, leave this field blank.
Password For Proxy Server (For Call Home)		Optional. If a proxy server is needed, and the proxy server requires a user ID and password, record the password here. If no proxy server is used, or no user ID and password are used, leave this field blank.

If a proxy server is not used, your network must provide access to the following addresses and ports to facilitate call home.

Table 13. All the information in this table is required.

Host Name	IP Address	Port	Description
eccgw01.boulder.ibm.com	207.25.252.197	443	ECC transaction gateway
eccgw02.rochester.ibm.com	129.42.160.51	443	ECC transaction gateway
ftp.ecurep.ibm.com	192.109.81.7	20, 21	File upload for status reporting and problem reporting through FTP
www6.sfoftware.ibm.com	170.225.15.41	443	File upload for status reporting and problem reporting. Proxy to testcase.boulder.ibm.com
www-945.ibm.com	129.42.26.224	443	Problem reporting server v4

Table 13. All the information in this table is required. (continued)

Host Name	IP Address	Port	Description
www-945.ibm.com	129.42.34.224	443	Problem reporting server v4
www-945.ibm.com	129.42.42.224	443	Problem reporting server v4
www.ibm.com	129.42.56.216	80, 443	Service provider file (CCF) download
www.ibm.com	129.42.58.216	80, 443	Service provider file (CCF) download
www.ibm.com	129.42.60.216	80, 443	Service provider file (CCF) download
www-03.ibm.com	204.146.30.17	80, 443	Service provider file (CCF) download

Table 14. CIDR subnet mask information

Subnet Mask	CIDR Equivalent	Note
255.255.255.255	/32	Host (single address)
255.255.255.254	/31	Unusable
255.255.255.252	/30	2 usable
255.255.255.248	/29	6 usable
255.255.255.240	/28	14 usable
255.255.255.224	/27	30 usable
255.255.255.192	/26	62 usable
255.255.255.128	/25	126 usable
255.255.255.0	/24	Class C 254 usable
255.255.254.0	/23	2 Class Cs
255.255.252.0	/22	4 Class Cs
255.255.248.0	/21	8 Class Cs
255.255.240.0	/20	16 Class Cs
255.255.224.0	/19	32 Class Cs
255.255.192.0	/18	64 Class Cs
255.255.128.0	/17	128 Class Cs
255.255.0.0	/16	Class B
255.254.0.0	/15	2 Class Bs
255.252.0.0	/14	4 Class Bs
255.248.0.0	/13	8 Class Bs
255.240.0.0	/12	16 Class Bs
255.224.0.0	/11	32 Class Bs
255.192.0.0	/10	64 Class Bs
255.128.0.0	/9	128 Class Bs
255.0.0.0	/8	Class A
254.0.0.0	/7	2 Class As
254.0.0.0	/6	4 Class As

Table 14. CIDR subnet mask information (continued)

Subnet Mask	CIDR Equivalent	Note
252.0.0.0	/5	2 Class As
248.0.0.0	/4	8 Class As
224.0.0.0	/3	16 Class As
192.0.0.0	/2	32 Class As
128.0.0.0	/1	64 Class As
0.0.0.0	/0	IP space

Table 15. Authentication method information

Field	Value	Note
<b>Authentication Method</b>	<input type="checkbox"/> Microsoft Active Directory (AD) <input type="checkbox"/> Lightweight Directory Access Protocol (LDAP) <input type="checkbox"/> Samba Primary Domain Controller (PDC) - NT4 <input type="checkbox"/> None (requires configuring Network Information Service (NIS) for NFS NetGroup support)	Check one of the options.  If you check <b>None</b> , do not select either of the following NIS options.
<b>Options</b>	<input type="checkbox"/> Kerberos, compatible with authentication method of LDAP only <input type="checkbox"/> Services For UNIX (SFU) - compatible with authentication method of AD only <input type="checkbox"/> Network Information Service (NIS) - NFS NetGroup support <b>without User ID Mapping</b> - compatible with authentication method of AD or PDC only. <input type="checkbox"/> Network Information Service (NIS) - NFS NetGroup support authentication method <b>with User ID Mapping</b> - compatible with authentication method of AD or PDC only.	One or more of these optional capabilities may be used to extend the capabilities of the authentication method selected previously. If none of these options are needed then leave this row blank.

If you checked Microsoft Active Directory in the **Authentication Method** field of Table 15, then you must complete this table.

Table 16. Active Directory Configuration Information

Field	Value	Note
<b>Active Directory Server Ip Address</b>	 _____ _____ _____	This is the numeric IP address of the remote Active Directory server (domain controller) on the customer's network.



Table 16. Active Directory Configuration Information (continued)

Field	Value	Note
Active Directory Userid		This is the user ID that must be provided when communicating with the remote Active Directory server. The following user ID and the password are used to authenticate to the Active Directory server.
Active Directory Password		This is the password that must be provided when communicating with the remote Active Directory server.
SFU DOMAIN NAME		<p>If you checked <b>Services For Unix (SFU)</b> in the <b>Options</b> field of Table 15 on page 54, then you must complete this field. If you did not check SFU, leave this field blank.</p> <p>This field is used to specify the Trusted Domain Name for the Active Directory server.</p>
SFU RANGE	Upper range: _____ Lower range: _____	<p>If you checked <b>Services For Unix (Sfu)</b> in the <b>Options</b> field of Table 15 on page 54, then you must complete this field. If you did not check SFU, leave this field blank.</p> <p>This field is used to specify the Lower and Upper bounds of the User Identifier (UID) and Group Identifier (GID) ranges for the storage system. Use the format Lower-Upper (for example, 25-37).</p> <p>The SFU Range must contain the UNIX UID/GID numbers corresponding to users/groups who need to access the system with SFU.</p> <p>The primary group assigned to the SFU users must be an existing Active Directory group with a valid UNIX GID assigned to it. The SFU users must have the same UNIX Attribute primary group and Windows primary group.</p> <p>The UNIX UID/GID that are assigned to such users/groups must be in the ID range provided with -cp parameter of the <b>cfgsfu</b> command. The range for UID/GID must not intersect with 10000000-11000000, this range is used by Scale Out Network Attached Storage internally for other UID/GID mapping</p>

Table 16. Active Directory Configuration Information (continued)

Field	Value	Note
SFU SCHEMA MODE	<input type="checkbox"/> SFU <input type="checkbox"/> rfc2307	<p>If you checked <b>Services For Unix (Sfu)</b> in the <b>Options</b> field of Table 15 on page 54, then you must complete this field. If you did not check SFU, leave this field blank.</p> <p>This field is used to specify the schema Mode. The schema Mode can be either <b>sfu</b> or <b>rfc2307</b> depending on the operating system of the Active Directory domain server. If the operating system of the domain server is Microsoft Windows 2008 or Windows 2003 with SP2R2 packages use the schemaMode of <b>rfc2307</b> for Windows 2000 and Windows 2003 with SP1, use <b>sfu</b>.</p>

If you checked **LDAP** in the **Authentication Method** field of Table 15 on page 54, then you must complete this table.

Table 17. LDAP CONFIGURATION INFORMATION

Field	Value	Note
LDAP SERVER IP ADDRESS	<p>_____</p> <p>_____</p>	This is the numeric IP address of the remote LDAP server on the customer's network.
SECURITY METHOD	<input type="checkbox"/> Off <input type="checkbox"/> SSL (Secure Sockets Layer) <input type="checkbox"/> TLS (Transport Layer Security)	<p>The communications link between the IBM SONAS and the customer's LDAP server may be open (unencrypted), or may be secured (encrypted). If secured, one of two methods is used: SSL or TLS.</p> <p><b>Note:</b> When SSL or TLS is used, a security certificate file must be copied from the customer's LDAP server to the IBM SONAS Management Node.</p>
Certificate Path		If the SSL method is Off, leave this field blank. If the SSL method is SSL or TLS, record the path on the IBM SONAS Management Node where you copy the Certificate file. As an example, if the Certificate File is cacert.pem and you store it in a directory called /certificates, then record <b>/certificates/cacert.pem</b> .
User Suffix		Specifies the LDAP user suffix to be used.
Group Suffix		Specifies the LDAP group suffix to be used.
Bind Distinguished Name		This is the bind distinguished name from the /etc/openldap/slapd.conf file on the customer's LDAP server. In the example following note 1 below, the bind distinguished name is <b>cn=Manager,dc=sonasldap,dc=com</b>

Table 17. LDAP CONFIGURATION INFORMATION (continued)

Field	Value	Note
Bind Password		This is the bind password from the /etc/openldap/slapd.conf file on the customer's LDAP server. In the example following note 1 below, the bind password is <b>secret</b> .
Kerberos Server Name		If you checked <b>Kerberos</b> in the <b>Options</b> field of Table 15 on page 54, then you must complete this field. If you did not check Kerberos, leave this field blank. This field is the name of the Kerberos server used with your LDAP environment.
Kerberos Realm		If you checked <b>Kerberos</b> in the <b>Options</b> field of Table 15 on page 54, then you must complete this field. If you did not check Kerberos, leave this field blank. This field is the Realm for the Kerberos server used with your LDAP environment.
Kerberos Keytab File		If you checked <b>Kerberos</b> in the <b>Options</b> field of Table 15 on page 54, then you must complete this field. If you did not check Kerberos, leave this field blank. This field is the file name for the Kerberos KeyTab file.

Table 18. NIS configuration information

Field	Value	Note
NIS MODE	<p><input type="checkbox"/> Basic - NIS is used (to provide NFS NetGroup support) in an environment without Active Directory (AD), LDAP, or Samba Primary Domain Controller (PDC).</p> <p><input type="checkbox"/> Extended - NIS is used (to provide NFS NetGroup support or to map UNIX IDs to Windows IDs) for an environment where Active Directory (AD) or Samba Primary Domain Controller (PDC) is used for Authentication.</p>	<p>NIS is typically used for one of the following purposes:</p> <ul style="list-style-type: none"> <li>• NIS can be used to provide NFS Netgroup support in an environment <b>without</b> AD, LDAP, or PDC.</li> <li>• NIS can be used to provide NFS Netgroup support in an environment <b>with</b> AD, or PDC.</li> <li>• NIS can be used to provide NFS NetGroup support and map UNIX user IDs (which are numeric) to Windows user IDs (which are text strings), allowing UNIX servers to access Network Attached Storage devices that use Microsoft Active Directory or PDC to authenticate users.</li> </ul> <p>If you checked <b>None</b> in the <b>Authentication Method</b> field of Table 15 on page 54, then select Basic.</p> <p>If you checked either of the NIS items in the <b>Options</b> field of Table 15 on page 54, then select Extended.</p>

Table 18. NIS configuration information (continued)

Field	Value	Note
<b>Domain Map</b>		<p>If the NIS Mode is Basic, leave this field blank.</p> <p>If the NIS mode is Extended, this field is optional.</p> <p>This field can be used to specify the mapping between AD domains and different NIS domains.</p> <p>When specifying a domain map, use a colon between the AD domain and the NIS domain or domains. Example: ad_domain:nis_domain1</p> <p>If more than one NIS domain is specified, use a comma-separated list. Example: ad_domain:nis_domain1,nis_domain2</p> <p>To specify more than one AD domain, use a semicolon. Example: ad_domain1:nis_domain1,nis_domain2; ad_domain2:nis_domain3,nis_domain4</p>
<b>Server Map</b>		<p>This field must be used to specify the mapping between NIS servers and NIS domains.</p> <p>When specifying a server map, use a colon between the NIS server and the NIS domain or domains. Example: nis_server:nis_domain1</p> <p>If more than one NIS domain is specified, use a comma-separated list. Example: nis_server:nis_domain1,nis_domain2</p> <p>To specify more than one NIS server, use a semicolon. Example: nis_server1:nis_domain1,nis_domain2; nis_server2:nis_domain3,nis_domain4</p>

Table 18. NIS configuration information (continued)

Field	Value	Note
User Map		<p>If the NIS Mode is Basic, leave this field blank.</p> <p>This optional field can be used to specify the handling for a user who is not known to the NIS server. Only one rule can be specified for each AD or PDC domain.</p> <p>The handling is specified using one of the following keywords:</p> <ul style="list-style-type: none"> <li>• DENY_ACCESS - denies any user from the specified domain access if they do not have a mapping entry in the NIS. Example: ad_domain1:DENY_ACCESS</li> <li>• AUTO - a new ID for the user is generated from the specific domain which does not have an entry in the NIS. This ID is generated from a pre-specified ID range and is auto-incremented. The administrator must make sure that existing NIS IDs do not fall in this provided ID range. This mapping is kept in Scale Out Network Attached Storage and NIS is not aware of this ID mapping. The ID range can be specified using the ID Map User Range and ID Map Group Range options. Example: ad_domain1:AUTO</li> <li>• DEFAULT - any user from the specified domain who does not have a mapping entry in the NIS server is mapped to a specified user (typically a guest user). Example: ad_domain1:DEFAULT:ad_domain\guest</li> </ul> <p>To specify rules for multiple AD or PDC domains, separate the rules with a semicolon. Example: ad_domain1:DENY_ACCESS; ad_domain2:AUTO; ad_domain3:DEFAULT:ad_domain3\guest</p>
NIS DOMAIN		<p>This field must be used to specify the NIS Domain that is stored in the registry.</p>
Use Id Map	<p><input type="checkbox"/> Use ID Map - NIS is used to map UNIX IDs to Windows IDs for an environment where Active Directory (AD) or Samba Primary Domain Controller (PDC) is used for Authentication.</p>	<p>If the NIS Mode is Basic, leave this field blank.</p> <p>If you checked NIS - NFS NetGroup support <b>without User ID Mapping</b> in the <b>Options</b> field of Table 15 on page 54, leave this field blank.</p> <p>If you checked NIS - NFS NetGroup support <b>with User ID Mapping</b> in the <b>Options</b> field of Table 15 on page 54, then check the Use ID Map field.</p>

Table 18. NIS configuration information (continued)

Field	Value	Note
ID MAP USER RANGE		<p>If the Use ID Map field is blank, leave this field blank.</p> <p>If the Use ID Map field is checked AND at least one User Map rule is AUTO then you must specify a User Range and/or a Group Range. Example: 10000-20000. <b>Note:</b> The User Range values must be a minimum of 1024.</p>
ID MAP GROUP RANGE		<p>If the Use ID Map field is blank, leave this field blank.</p> <p>If the Use ID Map field is checked AND at least one User Map rule is AUTO then you must specify a User Range and/or a Group Range. Example: 30000-40000. <b>Note:</b> The Group Range values must be a minimum of 1024.</p>

1. Go to a personal computer that has an Ethernet connection to the file module management IP address (refer to Table 9 on page 45), and point a supported browser to that address. Use https prefix (for example, https://9.11.136.208 ). You must use a supported browser. You can verify that you are using a supported browser by going to the Support home website at [www.ibm.com/storage/support/storwize/v7000](http://www.ibm.com/storage/support/storwize/v7000) and doing the following steps:
  - a. From the Search support input field, type **browser**. You are shown a search result for **IBM Storwize V7000 Supported Hardware List, Device Driver, Firmware and Recommended Software Levels**. Click the search entry.
  - b. Scroll down to the **Other Hardware and Software** section.
  - c. Find and select **Management GUI**.
2. Log in with the admin password **admin**.

#### Easy Setup Wizard:

**Note:** For each window, complete the required information, then select **Next**, verify that there is a green check mark when the task results are presented, and select **Close**. If there is an error select the **Details** drop-down arrow and determine the issue.

1. Accept the license agreement.
2. Complete the system attributes as required. Refer to Table 11 on page 49. Select **Next**.
3. At the **System License** window, leave the values at **0** if you are not using this feature. For more information about external virtualization go to [www.ibm.com/storage/support/storwize/v7000](http://www.ibm.com/storage/support/storwize/v7000). In the **Search support** box enter **external virtualization**.
4. If you want to set up support notifications now, select **Configure Support Notifications Now**, if not, select **Next**.
  - a. If you select **Configure Support Notifications Now** then complete all the information as prompted, such as **Email server IP address**, then move to the next window.

- b. Choose if you want to enable a proxy server from the **Configure Support Notifications** window, then select **Finish**.
5. If multiple entries from the **Domain Name Service (DNS)** are needed, enter one address then hit the + (plus) to add more.
6. Select **Edit** to indicate how the system authenticates users. Use table Table 15 on page 54 to work through the authentication strategy outlined in the tables.
7. Review the hardware image and verify that it reflects your configuration. Refer to the onscreen instructions and take the recommended actions if necessary.

**Note:** Depending on your server placement in the frame, the rack locations may not match.

8. It is recommended that you select **yes** to automatically configure the storage. You can choose to skip this step by selecting **Next** and configure the storage using the GUI at a later time.

**Note:** You have to configure the storage before using the system.

9. At the Public Networks window select the **New Network** button to add one or more public network addresses. Refer to Table 11 on page 49 for information to set up the public network information.
  - The Subnet is entered as the subnet address followed by the CIDR equivalent of the subnet mask (for example 9.11.100.100/32).
  - The Interface drop down menu specifies the network interface (for example, ethX0) to use for attaching the network. It is important to make a selection. If you leave the selection as **Not Attached** you are unable to attach new public addresses to the network
10. Select **OK**, then **Finish**, then **Close** to complete the Easy Setup Wizard. The file modules reboot. Allow 15 minutes for the system to come back up before continuing.

### Schedule a periodic backup of the TDB:

The Trivial DataBase (TDB) is used to store various types of information used to manage the system. It is recommended that you set up a periodic backup of the TDB, so backups are available to support personnel, in the event a TDB becomes lost or corrupted.

1. ssh to the file module management IP address (refer to Table 9 on page 45). Log in with user ID **admin** and password **admin**.
2. Type **mktask BackupTDB --minute 0 --hour 2 --dayOfWeek "\*"'**

**Note:** If you are prompted with following message, the management service is probably not up from the reboot. Wait a few minutes and try again:

```
IBM SONAS management service is stopped
EFSSG0026I Cannot execute commands because Management Service is stopped. Use startmgtsrv to r
```

The previous command schedules a backup of the Trivial DataBase at 2:00 a.m. every day. If you want to schedule the backup at a different time, change the number following the hour parameter. The 2 in the command can range from 0 (midnight) to 23 (11 p.m.).

3. Press **Enter**.
4. Exit the ssh session.

---

## Change default passwords

Use the ssh connection to set the superuser, root, and admin passwords.

For best security practices, it is always recommended that you change the default passwords for the superuser, root, and admin passwords. Make sure you record the new passwords in a secure location.

**Note:** A good password should be at least eight characters in length and contain a mix of uppercase letters, lowercase letters, and numbers.

1. First ssh to the file module management IP address (refer to Table 11 on page 49) using port 22. Log in with user ID **admin** and password **admin**.
2. Change the default superuser password for the control enclosure. Issue command `svctask chuser -password superuser_password superuser`, where `superuser_password` is the new superuser password that you want to use. **The password must be a minimum of 6 characters.**
3. Change the default root password for the management node. Issue command `chrootpwd` and follow the prompts to change the password. **The password must be a minimum of 5 characters.**
4. Change the default admin password for the management node. Issue command `chuser admin -p new_password` where `new_password` is the new password that you want to use. **The password must be a minimum of 8 characters.**
5. Type `exit` to close the connection.

---

## Check the Storwize V7000 Unified system status

To Check the health status of the system follow these procedures.

1. Log into the management GUI, if not already logged in from the previous step.
2. Check the **Health Status** in the lower right corner of the GUI.
3. If there are any warning or errors noted, hover over the **Monitoring** icon on the left of the page and select **Events**. A listing of errors will be posted.
4. Click on the error for further analysis and details of corrective actions to take.

---

## Upgrade the Storwize V7000 Unified software

Use the management GUI to install the latest Storwize V7000 Unified software.

Select **Settings** and then **General** from the management GUI. From the **General** menu select **Upgrade Software**. This page will help you to search for upgrades, get upgrades, and install an upgrade.

---

## Problems with initial configuration

This topic helps you to solve configuration problems.

### If USB key is missing or faulty:

- Contact the IBM Support Center.
- Install the latest InitTool.exe (or reinstall if tool is not launching). Go to <http://www-933.ibm.com/support/fixcentral/options> and select the following options to locate the tool. The options are listed under the **Select product** tab, at the bottom of the page:



- Product Group: **Storage Systems**
- Product Family: **Disk Systems**
- Product: **IBM Storwize V7000 Unified**
- Release: **All**
- Platform: **All**

Before loading the USB key verify it has a FAT32 formatted file system. Plug the USB key into the laptop. Go to Start (my computer), right-click the USB drive. The general tab next to File system should say FAT32.

- If the USB key is not formatted as FAT32, format it. To format, right-click it, select format, under filesystem. Select FAT32 and then click Start. Continue as prompted.

**InitTool.exe is not loaded on the USB key, or fails to launch:**

- Install the latest InitTool.exe (or reinstall if tool is not launching). Go to <http://www-933.ibm.com/support/fixcentral/options> and select the following options to locate the tool. The options are listed under the **Select product** tab, at the bottom of the page:
  - Product Group: **Storage Systems**
  - Product Family: **Disk Systems**
  - Product: **IBM Storwize V7000 Unified**
  - Release: **All**
  - Platform: **All**

**Amber LED on node canister does not stop flashing during install:**

Allow at least 15 minutes for the LED to stop flashing. If flashing continues beyond 15 minutes, remove the USB key and insert in your laptop. Navigate to the `satask_results.html` file and scan for errors and follow the service action recommendation. Take that action and retry installation.

**An error is posted in the `satask_results` html:**

Take the recommended action, reboot the node, and restart the procedure.

**File module code (CD) not loading:**

- Check CD for blemishes and clean the problem CD.
- Reboot the server and try again.
- Try another CD if one is available.

**Blue LED on file module, where the USB key was inserted, keeps flashing (does not turn solid as stated in the instructions):**

- Allow 5 minutes at least, remove the USB key, insert it into your laptop. Verify that the InitTool set up information is correct, navigate to the `SONAS_results.txt` file, and open it. Check for errors and corrective actions. Refer to *Storwize V7000 Unified Problem Determination Guide* PDF on the CD.
- If no errors are listed, reboot the server (allow server to start), reinsert the USB key, and try again.

**Blue LED on the other file module (without USB key) keeps flashing (does not turn solid or off as listed in instructions):**

Wait for the primary file module to start flashing, remove the USB key, insert it into your laptop, verify the InitTool set up information is correct, navigate to the SONAS\_results.txt file and open it. Check for errors and corrective actions (refer to *Storwize V7000 Unified Problem Determination Guide* PDF on the CD). If no errors are listed, reboot both file modules, allow file modules to boot completely, reinsert the USB key as originally instructed and try again.

#### Installed with the incorrect control enclosure or file module IP addresses:

If it is determined that the addresses were entered incorrectly, they can be changed at the command line as user **admin** with the following commands:

- For control enclosure IP changes use: **svctask chsystemip**
- For file module management node changes use: **chnwmgmt**

Refer to the man pages for usage.

---

## Enable IBM Tivoli Assist On-Site (AOS)

IBM Tivoli Assist On-Site (AOS) is a lightweight remote support program intended primarily for help desks and support engineers to diagnose and fix problems without the need of any external dependencies. Assist On-Site is based on the IBM Tivoli Remote Control technology.

Assist On-Site has been developed specifically to meet functionality, security, and privacy requirements of IBM and IBM customers. Support engineers and their customers can run it on various platforms. It currently has a native version for the 32 bit Windows environment and generic Linux compatible operating systems. Assist On-Site uses IBM AES MARS encryption, NTLM authentication, and IBM intranet authentication for IBM support engineers. Assist On-Site can also support lightweight Rational® Host Access Transformation Services emulator sessions for computers running z/OS® and Power i.

Assist On-Site provides a launch-in-context feature such that support engineers can start Assist On-Site from within the session of the third-party support tool. For restricted use only, Assist On-Site supports IBM diagnostic tools to function over the Assist On-Site connection for the purpose of debugging hardware devices and IBM software.

The AOS feature is disabled by default. To enable it, do the following:

1. From the Storwize V7000 Unified GUI, select **Support**, under **Setting** icon.
2. Click the **AOS** tab.
3. Click the **Edit** button at the bottom.
4. Click **Enable Assist on Site (AOS)**
5. Select either **Lights On** or **Lights Out**. For Storwize V7000 Unified it is recommended to select **Lights Out**. **Lights On** establishes a connection through the local console of the system and thus requires the specific file module to have a keyboard, mouse, and monitor attached for local access and connectivity. **Lights Out** allows for remote support connection to be accepted automatically by the system.
6. Enter any proxy settings if required for AOS.

**Note:** Establishment of an AOS connection requires access to ports 80, 443, and 8200. It provides the ability to make direct outgoing TCP connections, availability of a SOCKS server, or an HTTP proxy.

l

7. Click on **OK** to complete this procedure.



---

## Appendix. Accessibility

Accessibility features help a user who has a physical disability, such as restricted mobility or limited vision, to use software products successfully.

### Features

This list includes the major accessibility features in the management GUI:

- You can use screen-reader software and a digital speech synthesizer to hear what is displayed on the screen. The following screen reader has been tested: JAWS 11.
- Most of the GUI features are accessible by using the keyboard. For those features that are not accessible, equivalent function is available by using the command-line interface (CLI).

### Navigating by keyboard

You can use keys or key combinations to perform operations and initiate many menu actions that can also be done through mouse actions. You can navigate the management GUI and help system from the keyboard by using the following key combinations:

- To navigate between different GUI panels, select the Low-graphics mode option on the GUI login panel. You can use this option to navigate to all the panels without manually typing the web addresses.
- To go to the next frame, press Ctrl+Tab.
- To move to the previous frame, press Shift+Ctrl+Tab.
- To navigate to the next link, button, or topic within a panel, press Tab inside a frame (page).
- To move to the previous link, button, or topic within a panel, press Shift+Tab.
- To select GUI objects, press Enter.
- To print the current page or active frame, press Ctrl+P.
- To expand a tree node, press the Right Arrow key. To collapse a tree node, press the Left Arrow key.
- To scroll all the way up, press Home; to scroll all the way down, press End.
- To go back, press Alt+Left Arrow key.
- To go forward, press Alt+Right Arrow key.
- For actions menus:
  - Press Tab to navigate to the grid header.
  - Press the Left or Right Arrow keys to reach the drop-down field.
  - Press Enter to open the drop-down menu.
  - Press the Up or Down Arrow keys to select the menu items.
  - Press Enter to launch the action.
- For filter panes:
  - Press Tab to navigate to the filter panes.
  - Press the Up or Down Arrow keys to change the filter or navigation for nonselection.

- Press Tab to navigate to the magnifying glass icon in the filter pane and press Enter.
- Type the filter text.
- Press Tab to navigate to the red X icon and press Enter to reset the filter.
- For information areas:
  - Press Tab to navigate to information areas.
  - Press Tab to navigate to the fields that are available for editing.
  - Type your edit and press Enter to issue the change command.

## **Accessing the publications**

You can find the HTML version of the IBM Storwize V7000 Unified information at the following website:

[publib.boulder.ibm.com/infocenter/storwize/unified\\_ic/index.jsp](http://publib.boulder.ibm.com/infocenter/storwize/unified_ic/index.jsp)

You can access this information using screen-reader software and a digital speech synthesizer to hear what is displayed on the screen. The information was tested using the following screen reader: JAWS Version 10 or later.

---

## Notices

This information was developed for products and services offered in the U.S.A.

IBM may not offer the products, services, or features discussed in this document in other countries. Consult your local IBM representative for information on the products and services currently available in your area. Any reference to an IBM product, program, or service is not intended to state or imply that only that IBM product, program, or service may be used. Any functionally equivalent product, program, or service that does not infringe any IBM intellectual property right may be used instead. However, it is the user's responsibility to evaluate and verify the operation of any non-IBM product, program, or service.

IBM may have patents or pending patent applications covering subject matter described in this document. The furnishing of this document does not give you any license to these patents. You can send license inquiries, in writing, to:

*IBM Director of Licensing  
IBM Corporation  
North Castle Drive  
Armonk, NY 10504-1785  
U.S.A.*

For license inquiries regarding double-byte (DBCS) information, contact the IBM Intellectual Property Department in your country or send inquiries, in writing, to:

*Intellectual Property Licensing  
Legal and Intellectual Property Law  
IBM Japan, Ltd.  
1623-14, Shimotsuruma, Yamato-shi  
Kanagawa 242-8502 Japan*

**The following paragraph does not apply to the United Kingdom or any other country where such provisions are inconsistent with local law:**

INTERNATIONAL BUSINESS MACHINES CORPORATION PROVIDES THIS PUBLICATION "AS IS" WITHOUT WARRANTY OF ANY KIND, EITHER EXPRESS OR IMPLIED, INCLUDING, BUT NOT LIMITED TO, THE IMPLIED WARRANTIES OF NON-INFRINGEMENT, MERCHANTABILITY OR FITNESS FOR A PARTICULAR PURPOSE. Some states do not allow disclaimer of express or implied warranties in certain transactions, therefore, this statement may not apply to you.

This information could include technical inaccuracies or typographical errors. Changes are periodically made to the information herein; these changes will be incorporated in new editions of the publication. IBM may make improvements and/or changes in the product(s) and/or the program(s) described in this publication at any time without notice.

Any references in this information to non-IBM websites are provided for convenience only and do not in any manner serve as an endorsement of those websites. The materials at those websites are not part of the materials for this IBM product and use of those websites is at your own risk.

IBM may use or distribute any of the information you supply in any way it believes appropriate without incurring any obligation to you.

Licensees of this program who wish to have information about it for the purpose of enabling: (i) the exchange of information between independently created programs and other programs (including this one) and (ii) the mutual use of the information which has been exchanged, should contact:

*IBM Corporation  
Almaden Research  
650 Harry Road  
Bldg 80, D3-304, Department 277  
San Jose, CA 95120-6099  
U.S.A.*

Such information may be available, subject to appropriate terms and conditions, including in some cases, payment of a fee.

The licensed program described in this document and all licensed material available for it are provided by IBM under terms of the IBM Customer Agreement, IBM International Program License Agreement or any equivalent agreement between us.

Any performance data contained herein was determined in a controlled environment. Therefore, the results obtained in other operating environments may vary significantly. Some measurements may have been made on development-level systems and there is no guarantee that these measurements will be the same on generally available systems. Furthermore, some measurement may have been estimated through extrapolation. Actual results may vary. Users of this document should verify the applicable data for their specific environment.

Information concerning non-IBM products was obtained from the suppliers of those products, their published announcements or other publicly available sources. IBM has not tested those products and cannot confirm the accuracy of performance, compatibility or any other claims related to non-IBM products. Questions on the capabilities of non-IBM products may be addressed to the suppliers of those products.

All statements regarding IBM's future direction or intent are subject to change or withdrawal without notice, and represent goals and objectives only.

This information is for planning purposes only. The information herein is subject to change before the products described become available.

This information contains examples of data and reports used in daily business operations. To illustrate them as completely as possible, the examples include the names of individuals, companies, brands, and products. All of these names are fictitious and any similarity to the names and addresses used by an actual business enterprise is entirely coincidental.

#### COPYRIGHT LICENSE:

This information contains sample application programs in source language, which illustrate programming techniques on various operating platforms. You may copy, modify, and distribute these sample programs in any form without payment to IBM, for the purposes of developing, using, marketing or distributing application



programs conforming to the application programming interface for the operating platform for which the sample programs are written. These examples have not been thoroughly tested under all conditions. IBM, therefore, cannot guarantee or imply reliability, serviceability, or function of these programs. The sample programs are provided "AS IS", without warranty of any kind. IBM shall not be liable for any damages arising out of your use of the sample programs.

If you are viewing this information softcopy, the photographs and color illustrations may not appear.

---

## Trademarks

IBM, the IBM logo, and [ibm.com](http://ibm.com) are trademarks or registered trademarks of International Business Machines Corp., registered in many jurisdictions worldwide. Other product and service names might be trademarks of IBM or other companies. A current list of IBM trademarks is available on the web at Copyright and trademark information at [www.ibm.com/legal/copytrade.shtml](http://www.ibm.com/legal/copytrade.shtml).

Adobe and the Adobe logo are either registered trademarks or trademarks of Adobe Systems Incorporated in the United States, and/or other countries.

Intel, Intel logo, Intel Xeon, and Pentium are trademarks or registered trademarks of Intel Corporation or its subsidiaries in the United States and other countries.

Linux is a registered trademark of Linus Torvalds in the United States, other countries, or both.

Microsoft, Windows, Windows NT, and the Windows logo are trademarks of Microsoft Corporation in the United States, other countries, or both.

UNIX is a registered trademark of The Open Group in the United States and other countries.

Java and all Java-based trademarks and logos are trademarks or registered trademarks of Oracle and/or its affiliates.

Other product and service names might be trademarks of IBM or other companies.

---

## Electronic emission notices

The following electronic emission statements apply to this product. The statements for other products that are intended for use with this product are included in their accompanying documentation.

### **Federal Communications Commission (FCC) statement**

This explains the Federal Communications Commission's (FCC) statement.

This equipment has been tested and found to comply with the limits for a Class A digital device, pursuant to Part 15 of the FCC Rules. These limits are designed to provide reasonable protection against harmful interference when the equipment is operated in a commercial environment. This equipment generates, uses, and can radiate radio frequency energy and, if not installed and used in accordance with the instruction manual, might cause harmful interference to radio communications.

Operation of this equipment in a residential area is likely to cause harmful interference, in which case the user will be required to correct the interference at his own expense.

Properly shielded and grounded cables and connectors must be used in order to meet FCC emission limits. IBM is not responsible for any radio or television interference caused by using other than recommended cables and connectors, or by unauthorized changes or modifications to this equipment. Unauthorized changes or modifications could void the user's authority to operate the equipment.

This device complies with Part 15 of the FCC Rules. Operation is subject to the following two conditions: (1) this device might not cause harmful interference, and (2) this device must accept any interference received, including interference that might cause undesired operation.

## **Industry Canada compliance statement**

This Class A digital apparatus complies with ICES-003.

Cet appareil numérique de la classe A est conform à la norme NMB-003 du Canada.

## **Avis de conformité à la réglementation d'Industrie Canada**

Cet appareil numérique de la classe A est conforme à la norme NMB-003 du Canada.

## **Australia and New Zealand Class A Statement**

**Attention:** This is a Class A product. In a domestic environment this product might cause radio interference in which case the user might be required to take adequate measures.

## **European Union Electromagnetic Compatibility Directive**

This product is in conformity with the protection requirements of European Union (EU) Council Directive 2004/108/EC on the approximation of the laws of the Member States relating to electromagnetic compatibility. IBM cannot accept responsibility for any failure to satisfy the protection requirements resulting from a non-recommended modification of the product, including the fitting of non-IBM option cards.

**Attention:** This is an EN 55022 Class A product. In a domestic environment this product might cause radio interference in which case the user might be required to take adequate measures.

Responsible Manufacturer:

International Business Machines Corp.  
New Orchard Road  
Armonk, New York 10504  
914-499-1900

European community contact:

IBM Technical Regulations, Department M456  
IBM-Allee 1, 71137 Ehningen, Germany  
Tel: +49 7032 15-2937  
E-mail: [mailto: tjahn @ de.ibm.com](mailto:tjahn@de.ibm.com)

## Germany Electromagnetic compatibility directive

### **Deutschsprachiger EU Hinweis: Hinweis für Geräte der Klasse A EU-Richtlinie zur Elektromagnetischen Verträglichkeit**

Dieses Produkt entspricht den Schutzanforderungen der EU-Richtlinie 2004/108/EG zur Angleichung der Rechtsvorschriften über die elektromagnetische Verträglichkeit in den EU-Mitgliedsstaaten und hält die Grenzwerte der EN 55022 Klasse A ein.

Um dieses sicherzustellen, sind die Geräte wie in den Handbüchern beschrieben zu installieren und zu betreiben. Des Weiteren dürfen auch nur von der IBM empfohlene Kabel angeschlossen werden. IBM übernimmt keine Verantwortung für die Einhaltung der Schutzanforderungen, wenn das Produkt ohne Zustimmung der IBM verändert bzw. wenn Erweiterungskomponenten von Fremdherstellern ohne Empfehlung der IBM gesteckt/eingebaut werden.

EN 55022 Klasse A Geräte müssen mit folgendem Warnhinweis versehen werden:

"Warnung: Dieses ist eine Einrichtung der Klasse A. Diese Einrichtung kann im Wohnbereich Funk-Störungen verursachen; in diesem Fall kann vom Betreiber verlangt werden, angemessene Maßnahmen zu ergreifen und dafür aufzukommen."

### **Deutschland: Einhaltung des Gesetzes über die elektromagnetische Verträglichkeit von Geräten**

Dieses Produkt entspricht dem "Gesetz über die elektromagnetische Verträglichkeit von Geräten (EMVG)." Dies ist die Umsetzung der EU-Richtlinie 2004/108/EG in der Bundesrepublik Deutschland.

### **Zulassungsbescheinigung laut dem Deutschen Gesetz über die elektromagnetische Verträglichkeit von Geräten (EMVG) (bzw. der EMC EG Richtlinie 2004/108/EG) für Geräte der Klasse A**

Dieses Gerät ist berechtigt, in Übereinstimmung mit dem Deutschen EMVG das EG-Konformitätszeichen - CE - zu führen.

Verantwortlich für die Einhaltung der EMV Vorschriften ist der Hersteller:

International Business Machines Corp.  
New Orchard Road  
Armonk, New York 10504  
Tel: 914-499-1900

Der verantwortliche Ansprechpartner des Herstellers in der EU ist:

IBM Deutschland  
Technical Regulations, Department M456  
IBM-Allee 1, 71137 Ehningen, Germany  
Tel: +49 7032 15-2937  
e-mail: [mailto: tjahn @ de.ibm.com](mailto:tjahn@de.ibm.com)

**Generelle Informationen: Das Gerät erfüllt die Schutzanforderungen nach EN 55024 und EN 55022 Klasse A.**

## **Japan VCCI Council Class A statement**

この装置は、クラス A 情報技術装置です。この装置を家庭環境で使用すると電波妨害を引き起こすことがあります。この場合には使用者が適切な対策を講ずるよう要求されることがあります。 VCCI-A

## **People's Republic of China Class A Electronic Emission Statement**

中华人民共和国“A类”警告声明

声明

此为A级产品，在生活环境中，该产品可能会造成无线电干扰。在这种情况下，可能需要用户对其干扰采取切实可行的措施。

## **International Electrotechnical Commission (IEC) statement**

This product has been designed and built to comply with (IEC) Standard 950.

## **United Kingdom telecommunications requirements**

This apparatus is manufactured to the International Safety Standard EN60950 and as such is approved in the U.K. under approval number NS/G/1234/J/100003 for indirect connection to public telecommunications systems in the United Kingdom.

## **Korean Communications Commission (KCC) Class A Statement**

이 기기는 업무용(A급)으로 전자파적합기기로서 판매자 또는 사용자는 이 점을 주의하시기 바라며, 가정외의 지역에서 사용하는 것을 목적으로 합니다.

## Russia Electromagnetic Interference (EMI) Class A Statement

ВНИМАНИЕ! Настоящее изделие относится к классу А.  
В жилых помещениях оно может создавать радиопомехи, для снижения которых необходимы дополнительные меры

rusemi

## Taiwan Class A compliance statement

警告使用者：  
這是甲類的資訊產品，在居住的環境中使用時，可能會造成射頻干擾，在這種情況下，使用者會被要求採取某些適當的對策。

tailemi

---

### European Contact Information

This topic contains the product service contact information for Europe.

European Community contact:  
IBM Technical Regulations  
Pascalstr. 100, Stuttgart, Germany 70569  
Tele: 0049 (0)711 785 1176  
Fax: 0049 (0)711 785 1283  
Email: [mailto: tjahn @ de.ibm.com](mailto:tjahn@de.ibm.com)

---

### Taiwan Contact Information

This topic contains the product service contact information for Taiwan.

IBM Taiwan Product Service Contact Information:  
IBM Taiwan Corporation  
3F, No 7, Song Ren Rd., Taipei Taiwan  
Tel: 0800-016-888

台灣IBM 產品服務聯絡方式：  
台灣國際商業機器股份有限公司  
台北市松仁路7號3樓  
電話：0800-016-888

f2c00790







Part Number: 00L4640

Printed in USA

GA32-1056-02



(1P) P/N: 00L4640

