



IBM Storwize V7000
Quick Installation Guide

Version 6.2.0

GC27-2290-01





IBM Storwize V7000
Quick Installation Guide

Version 6.2.0

GC27-2290-01

Note

Before using this information and the product it supports, read the general information in “Notices” on page 27, the information in the “Safety and environmental notices” on page ix, as well as the information in the *IBM Environmental Notices and User Guide* on the documentation CD.

This edition applies to the IBM Storwize V7000, Version 6.2.0, and to all subsequent releases and modifications until otherwise indicated in new editions.

This edition replaces GC27-2290-00.

© **Copyright IBM Corporation 2010, 2011.**

US Government Users Restricted Rights – Use, duplication or disclosure restricted by GSA ADP Schedule Contract with IBM Corp.

Contents

Figures v

Tables vii

Safety and environmental notices . . . ix

Chapter 1. Before you begin the installation 1

- Step 1. Reviewing your packing slip 3
- Step 2. Identifying the hardware components 4
- Step 3. Verifying environmental requirements 8
- Step 4. Reviewing enclosure location guidelines . . . 9

Chapter 2. Performing the hardware installation 11

- Step 5. Installing the support rails 11
- Step 6. Installing the enclosures. 12
- Step 7. Connecting the SAS cables to the expansion enclosures 13
- Step 8. Attaching the Ethernet cables 17
- Step 9. Attaching the Fibre Channel longwave SFP transceivers 17
- Step 10. Attaching the Fibre Channel cables. 17
- Step 11. Attaching the 10 Gbps Ethernet cables . . . 18
- Step 12. Connecting the power cords 18
- Step 13. Powering on the system 19

Chapter 3. Configuring the system. . . 23

- Setting up your system for the first time with a control enclosure or a control enclosure and one or more expansion enclosures 23

- | Adding an expansion enclosure into an existing system 25
- | Adding another control enclosure into an existing system 25

Notices 27

- Trademarks 29
- Electronic emission notices 29
 - Federal Communications Commission (FCC) statement 29
 - Industry Canada compliance statement 30
 - Avis de conformité à la réglementation d'Industrie Canada 30
 - Australia and New Zealand Class A Statement 30
 - European Union Electromagnetic Compatibility Directive 30
 - Germany Electromagnetic compatibility directive 30
 - Japan VCCI Council Class A statement 31
 - People's Republic of China Class A Electronic Emission Statement. 31
 - International Electrotechnical Commission (IEC) statement 32
 - United Kingdom telecommunications requirements 32
 - Korean Communications Commission (KCC) Class A Statement 32
 - Russia Electromagnetic Interference (EMI) Class A Statement 32
 - Taiwan Class A compliance statement 32
- European Contact Information 32
- Taiwan Contact Information 33

Figures

1.	24 drives and two end caps	4	8.	Hole locations in the front of the rack.	11
2.	12 drives and two end caps	4	9.	Hole locations in the back of the rack.	12
3.	Rear view of a model 2076-112 or a model 2076-124 control enclosure	5	10.	Attaching an expansion enclosure to the control enclosure.	14
4.	Data ports and LEDs in the rear of the control enclosure.	6	11.	Adding a second expansion enclosure.	15
5.	10 Gbps Ethernet ports on the rear of the Storwize V7000 enclosure	7	12.	Attaching SAS cables to the enclosures	16
6.	Rear view of an expansion enclosure	7	13.	LEDs on the power supply units of the expansion enclosure.	20
7.	SAS ports and LEDs in rear of expansion enclosure.	8	14.	LEDs on the power supply units of the control enclosure	21
			15.	Initialization tool welcome panel	24

Tables

I	1.	Steps for the different scenarios	1	4.	LED status when control enclosure is powered on.	21
	2.	Cabling guide.	13			
	3.	LED status when expansion enclosures are powered on	20			

Safety and environmental notices

Review the multilingual safety notices for the IBM® Storwize® V7000 system before you install and use the product.

Suitability for telecommunication environment: This product is not intended to connect directly or indirectly by any means whatsoever to interfaces of public telecommunications networks.

To find the translated text for a caution or danger notice:

1. Look for the identification number at the end of each caution notice or each danger notice. In the following examples, the numbers (C001) and (D002) are the identification numbers.

CAUTION:

A caution notice indicates the presence of a hazard that has the potential of causing moderate or minor personal injury. (C001)

DANGER

A danger notice indicates the presence of a hazard that has the potential of causing death or serious personal injury. (D002)
--

2. Locate *IBM Storwize V7000 Safety Notices* with the user publications that were provided with the Storwize V7000 hardware.
3. Find the matching identification number in the *IBM Storwize V7000 Safety Notices*. Then review the topics concerning the safety notices to ensure that you are in compliance.
4. Optionally, read the multilingual safety instructions on the Storwize V7000 website. Go to the Support for Storwize V7000 website at www.ibm.com/storage/support/storwize/v7000 and click the documentation link.

Chapter 1. Before you begin the installation

The *Quick Installation Guide* contains a set of instructions to help you unpack your shipping order and install your system. The guide is divided into three chapters. The steps in the first chapter involve verifying your order, becoming familiar with the hardware component terminology, and ensuring that you have met the environmental requirements. The steps in the second chapter involve installing the hardware and attaching the data cables and power cords. The final chapter helps you create your configuration file and access the management GUI. The management GUI guides you through the initial configuration process.

See the following website for the available translated versions of the *Quick Installation Guide*:

Support for Storwize V7000 website at www.ibm.com/storage/support/storwize/v7000

Occasionally you are referred to topics in the Storwize V7000 Information Center. A copy of the Storwize V7000 Information Center is on the DVD that is included in your shipping order.

Note:

1. The guide assumes that you have read the planning information regarding your physical environment that is available from the Storwize V7000 Information Center.
2. Ensure that you have available any cables that you are supplying.

Depending on your order, this documentation steps you through setting up your system for the following scenarios

- Setting up a new system that consists of installing a control enclosure only. In this case, you are not installing any expansion enclosures.
- Setting up a new system that consists of installing a control enclosure and installing one or more expansion enclosures.
- Adding an expansion enclosure to an existing system. In this case, you initially installed a control enclosure or installed a control enclosure and one or more expansion enclosures. You want to add an expansion enclosure to your existing system. If you are adding an expansion enclosure to an existing system, you do not need to power off the system. You can add an expansion enclosure while the system is operational.
- Adding another control enclosure either by itself or with one or more expansion enclosures to an existing system. If you are adding another control enclosure to an existing system, you do not need to power off the system. You can add another control enclosure while the system is operational.

Note: To add another control enclosure, your system must be at a software level of 6.2.0 or later.

- Setting up a new system that consists of more than one control enclosure. You install the first control enclosure and then the required expansion enclosures. For other control enclosures, do the setup as if you were adding it to an existing system.

Table 1 identifies the order of the steps that you take for each of the different scenarios.

Table 1. Steps for the different scenarios

	New system that includes a control enclosure and one or more expansion enclosures	Adding expansion enclosures to an existing system	Adding control enclosures and expansion enclosures to an existing system
New system with control enclosure only	"Step 1. Reviewing your packing slip" on page 3	"Step 1. Reviewing your packing slip" on page 3	"Step 1. Reviewing your packing slip" on page 3

Table 1. Steps for the different scenarios (continued)

New system with control enclosure only	New system that includes a control enclosure and one or more expansion enclosures	Adding expansion enclosures to an existing system	Adding control enclosures and expansion enclosures to an existing system
"Step 2. Identifying the hardware components" on page 4	"Step 2. Identifying the hardware components" on page 4	"Step 3. Verifying environmental requirements" on page 8	"Step 3. Verifying environmental requirements" on page 8
"Step 3. Verifying environmental requirements" on page 8	"Step 3. Verifying environmental requirements" on page 8	"Step 4. Reviewing enclosure location guidelines" on page 9	"Step 4. Reviewing enclosure location guidelines" on page 9
"Step 4. Reviewing enclosure location guidelines" on page 9	"Step 4. Reviewing enclosure location guidelines" on page 9	"Step 5. Installing the support rails" on page 11 ²	"Step 5. Installing the support rails" on page 11 ¹
"Step 5. Installing the support rails" on page 11	"Step 5. Installing the support rails" on page 11 ¹	"Step 6. Installing the enclosures" on page 12 ²	"Step 6. Installing the enclosures" on page 12 ¹
"Step 6. Installing the enclosures" on page 12	"Step 6. Installing the enclosures" on page 12 ¹	"Step 7. Connecting the SAS cables to the expansion enclosures" on page 13 ²	"Step 7. Connecting the SAS cables to the expansion enclosures" on page 13 ²
"Step 8. Attaching the Ethernet cables" on page 17	"Step 7. Connecting the SAS cables to the expansion enclosures" on page 13 ²	"Step 12. Connecting the power cords" on page 18 ²	"Step 8. Attaching the Ethernet cables" on page 17 ¹
Optional: "Step 9. Attaching the Fibre Channel longwave SFP transceivers" on page 17	"Step 8. Attaching the Ethernet cables" on page 17 ¹	"Step 13. Powering on the system" on page 19 ²	"Adding another control enclosure into an existing system" on page 25
"Step 10. Attaching the Fibre Channel cables" on page 17	"Step 9. Attaching the Fibre Channel longwave SFP transceivers" on page 17 ¹	"Adding an expansion enclosure into an existing system" on page 25	Optional: "Step 9. Attaching the Fibre Channel longwave SFP transceivers" on page 17 ¹
"Step 12. Connecting the power cords" on page 18	"Step 10. Attaching the Fibre Channel cables" on page 17		"Step 10. Attaching the Fibre Channel cables" on page 17
"Step 13. Powering on the system" on page 19	"Setting up your system for the first time with a control enclosure or a control enclosure and one or more expansion enclosures" on page 23		"Step 11. Attaching the 10 Gbps Ethernet cables" on page 18
"Setting up your system for the first time with a control enclosure or a control enclosure and one or more expansion enclosures" on page 23			"Step 12. Connecting the power cords" on page 18
			"Step 13. Powering on the system" on page 19

¹ These steps are performed for each control enclosure and expansion enclosure that you add.

² These steps are performed for each expansion enclosure that you add.

Be familiar with the following information

- Where it is applicable, a CAUTION notice indicates situations that can be potentially hazardous to you. Before doing a step that contains a caution notice, read and understand the statement that accompanies it.
- Use safe practices when lifting. The fully populated enclosure weighs about 57.2 lbs (26 kg). At least two people are required to lift and install the enclosure into the rack or to remove an enclosure from the rack.

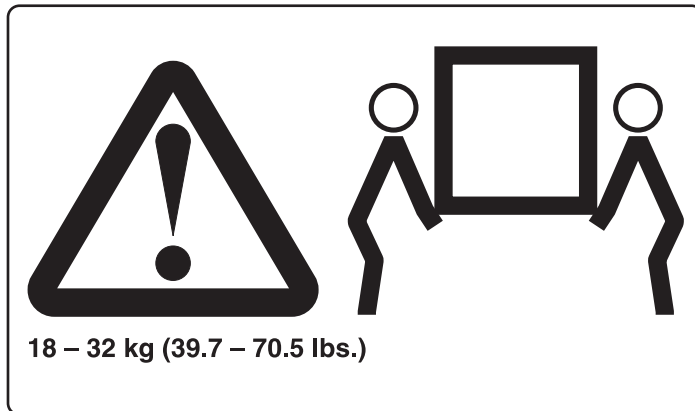

- Rack-mounted devices are not to be used as a shelf or workspace. Do not place any object on top of rack-mounted devices.

Tools needed

A screwdriver is the only tool needed for the system installation. The screwdriver can be either a flat-blade screwdriver or a crosshead screwdriver.

Step 1. Reviewing your packing slip

After you open your box or boxes, locate your packing slip. Ensure that the items that are listed in your packing slip match what is in the box. Ensure that any optional items that you ordered are included in the list. Your shipment might contain additional items depending on the order.

Standard ship group contents:

- ___ • Control enclosure (models 2076-112, 2076-124, 2076-312, or 2076-324) or expansion enclosure (models 2076-212 or 2076-224). The last two digits of the model number identify the number of drive slots. The last two digits are either 12 or 24.
 - ___ • Rack-mounting hardware kit, including:
 - ___ – Two rails (right and left assembly)
 - ___ – Two M5 x 15 Hex Phillips screws per rail (two rails)
 - ___ – Two M5 x 15 Hex Phillips screws per chassis
- Note:** Two parts of the rail kit are attached to each side of the enclosure.
- ___ • Two power cords
 - ___ • Drive assemblies or blank carriers (installed in the enclosure).
Verify the number of drives and the size of the drives.
 - ___ • Environmental Notices flyer
 - ___ • Limited Warranty information

- __ • Software DVD that contains the environmental notices, the publication PDFs, and the information center content. One DVD is shipped per enclosure.
- __ • License Function authorization document
- __ • Code Reference flyer
- | __ • *IBM Storwize V7000 Quick Installation Guide, GC27-2290*

Additional components for control enclosures:

- __ • USB key, also known as a flash drive, is located with the publications.
- __ • Fibre Channel cables, if ordered
- __ • Small form-factor pluggable (SFP) transceivers that are preinstalled in the enclosure
- __ • Longwave SFP transceivers, if ordered

Additional components for expansion enclosures:

- __ • Two SAS cables for each expansion enclosure

Step 2. Identifying the hardware components

- | The following graphics and descriptions identify the various hardware components and port locations for the control enclosure and the expansion enclosure. Each enclosure takes up the full 2U height in the rack.

See the *IBM Storwize V7000 Troubleshooting, Recovery, and Maintenance Guide* PDF on the DVD for the full descriptions of the hardware components.

Each enclosure has drives that are located on the front. Figure 1 and Figure 2 show the front of an enclosure that has space for up to 12 or 24 drives **2**, depending on the model, and a left end cap **1** and a right end cap **3**.

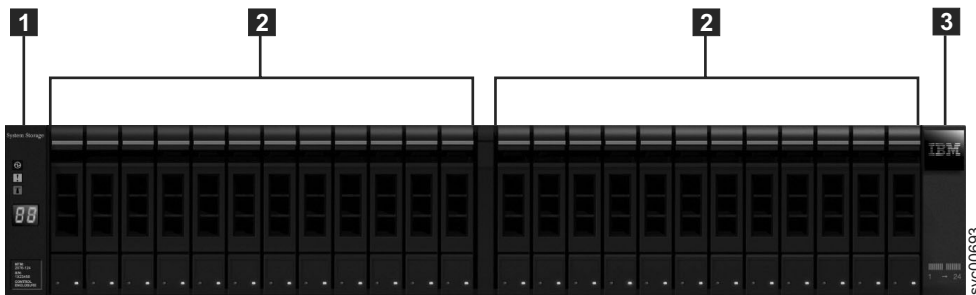

Figure 1. 24 drives and two end caps

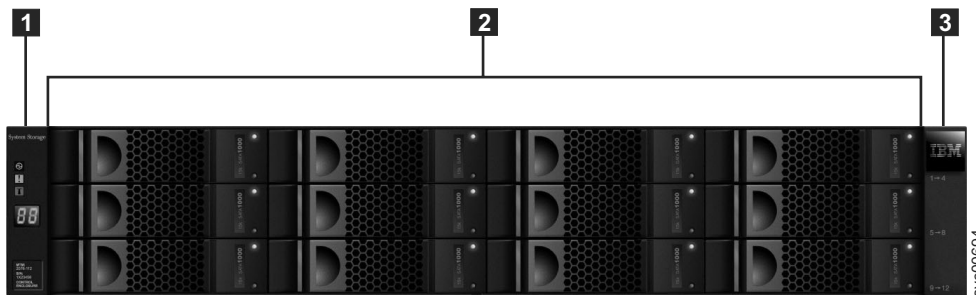

Figure 2. 12 drives and two end caps

Control enclosure components

Figure 3 shows the rear view of a control enclosure and identifies the location of the power supply units and the canisters.

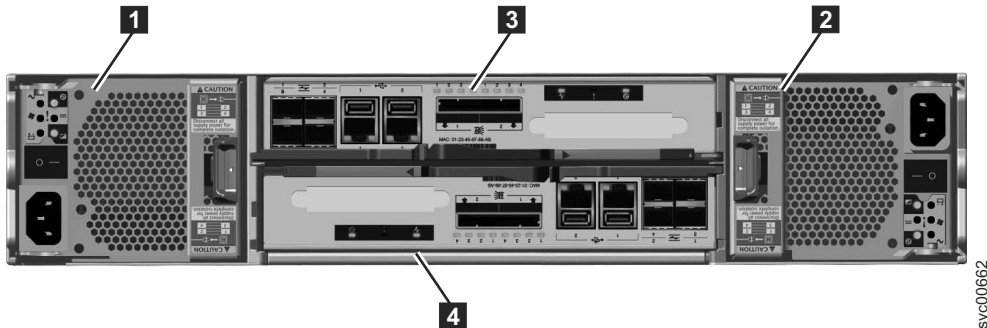

Figure 3. Rear view of a model 2076-112 or a model 2076-124 control enclosure

- Power supply units are located on the left and right of the canisters. Each unit contains a battery. Power supply 1 **1** is located on the left. Power supply 2 **2** is located on the right. Power supply 1 is inserted top side up, and power supply 2 is inverted, or top side down.

Important: The power supply units for the control enclosure and expansion enclosure are not interchangeable.

- Two canisters are housed in the middle of the enclosure. Each canister is known as a node canister. The upper canister is canister 1 **3**, and the lower canister is canister 2 **4**. Canister 1 is top side up, and canister 2 is inverted, or top side down.

Figure 4 on page 6 shows the rear view of a model 2076-112 or a model 2076-124 control enclosure and identifies the location of the ports.

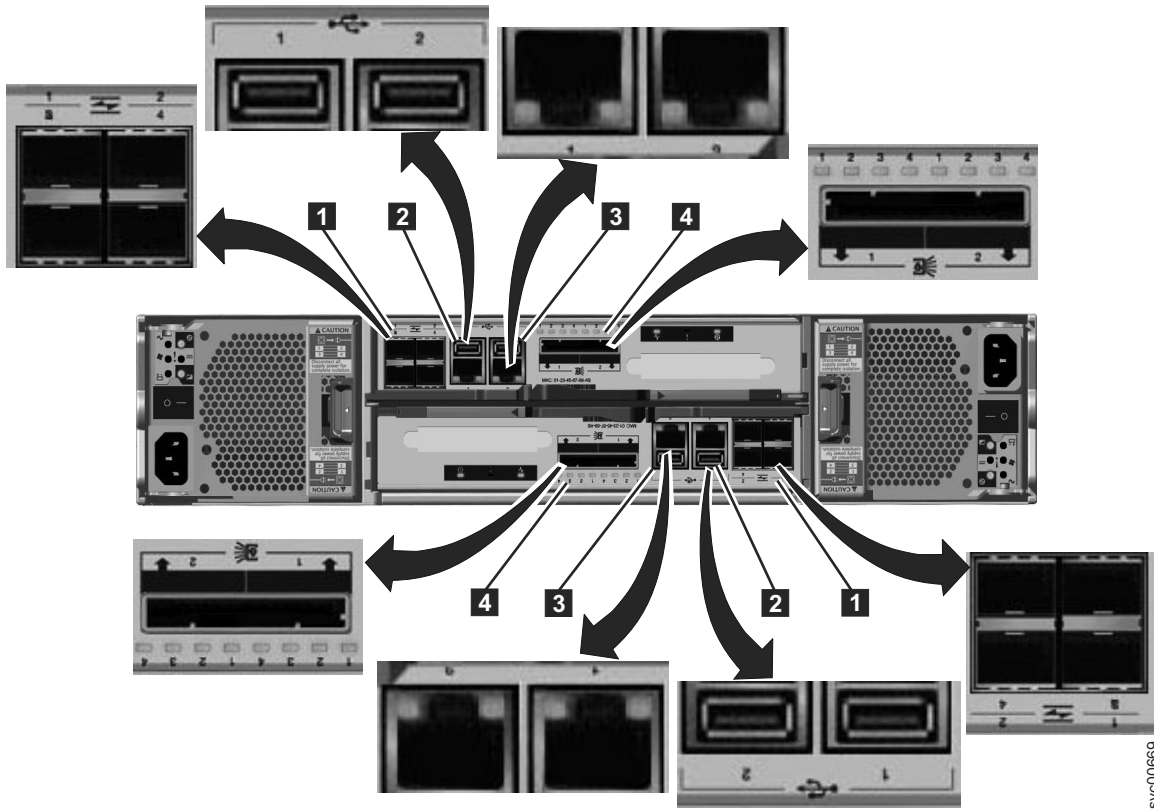
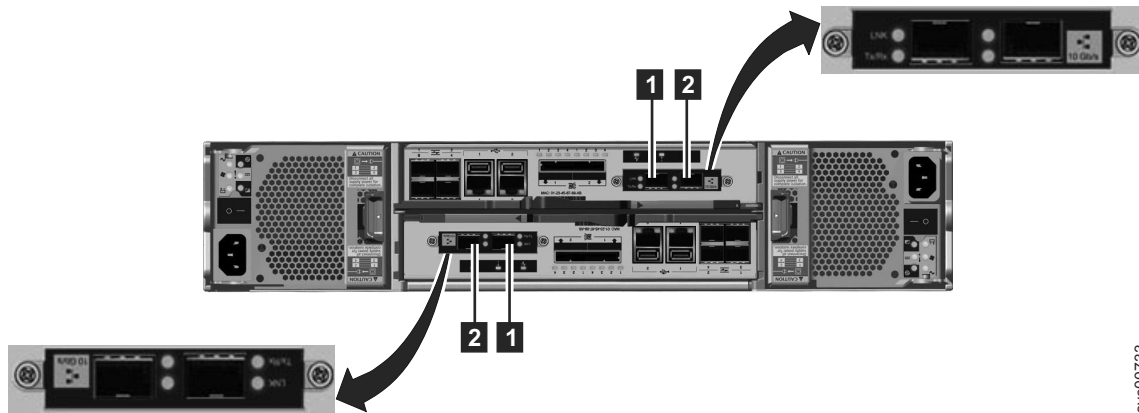

Figure 4. Data ports and LEDs in the rear of the control enclosure

- **1** Fibre Channel ports. Each canister has four Fibre Channel ports. They are in a block of four in two rows of two connectors. The ports are numbered 1 - 4 from left to right, top to bottom. Their use is optional.
- **2** USB ports. Each canister has two USB ports. The ports are side by side on the canister and are numbered 1 on the left and 2 on the right. One port is used during installation.
- **3** Ethernet ports. Each canister has two Ethernet ports. The ports are side by side on the canister. They are numbered 1 on the left and 2 on the right. Port 1 must be connected; the use of port 2 is optional.
- **4** Serial-attached SCSI (SAS) ports. Each canister has two SAS ports. The ports are side by side on the canister. They are numbered 1 on the left and 2 on the right. Port 1 must be connected if you are adding one expansion enclosure. Port 2 must be connected if you are adding a second expansion enclosure.

Note: The reference to the left and right locations applies to canister 1, which is the upper canister. The port locations are inverted for canister 2, which is the lower canister.

| Figure 5 on page 7 shows the rear view of a model 2076-312 or a model 2076-324 control enclosure. With
 | the exception of the 10 Gbps Ethernet ports, all other data ports are the same for all models.
 |



svc00733

Figure 5. 10 Gbps Ethernet ports on the rear of the Storwize V7000 enclosure

- **1** 10 Gbps Ethernet port 3 which is the left port.
- **2** 10 Gbps Ethernet port 4 which is the right port.

Expansion enclosure components

Figure 6 shows the rear view of an expansion enclosure and identifies the location of the power supply units and the canisters. The ports and their use are described later in this section.

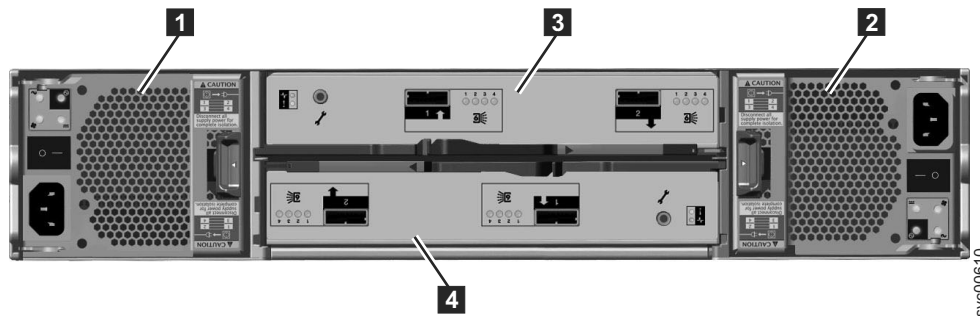

svc00610

Figure 6. Rear view of an expansion enclosure

- Power supply units are on the left and right of the canisters. Power supply 1 **1** is located on the left. Power supply 2 **2** is located on the right. Power supply 1 is inserted top side up, and power supply 2 is inverted, or top side down.

Important: The power supply units for the control enclosure and expansion enclosure are not interchangeable.

- Two canisters are housed in the middle of the enclosure. Each canister is known as an expansion canister. The upper canister is canister 1 **3**, and the lower canister is canister 2 **4**. Canister 1 is top side up, and canister 2 is inverted, or top side down.

Figure 7 on page 8 shows the rear view of an expansion enclosure and identifies the SAS port locations.

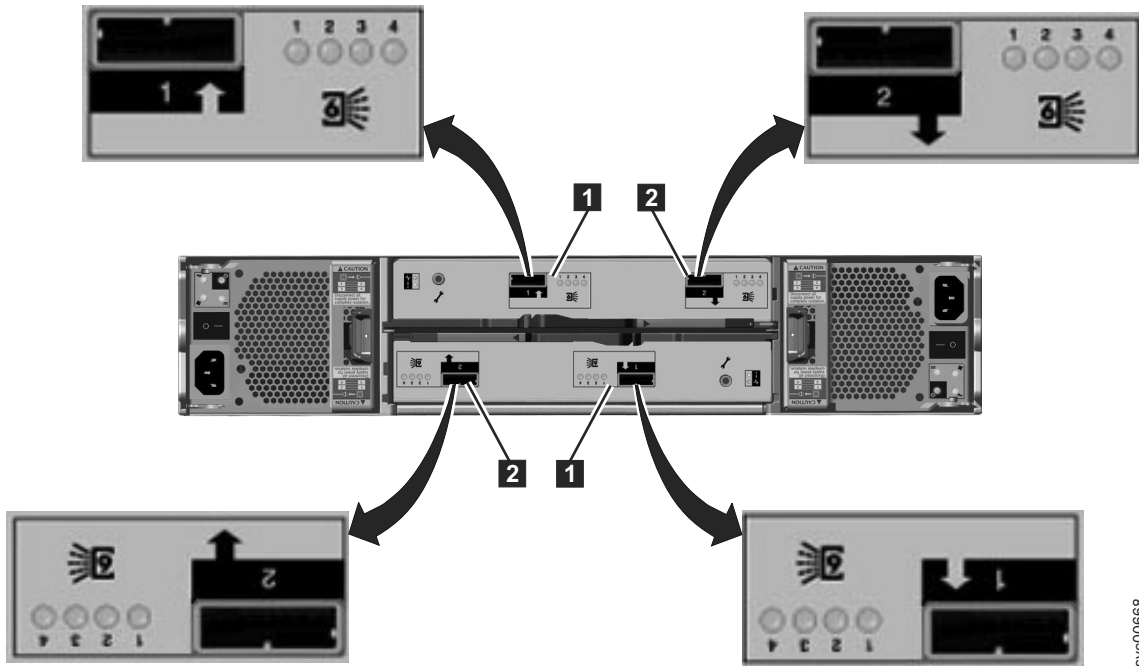

Figure 7. SAS ports and LEDs in rear of expansion enclosure

Each canister has two SAS ports that are numbered 1 on the left **1** and 2 on the right **2**. Port 1 must be connected if you are adding one expansion enclosure. Port 2 must be connected if you are adding a second expansion enclosure.

Note: The reference to the left and right locations applies to canister 1, which is the upper canister. The port locations are inverted for canister 2, which is the lower canister.

Miscellaneous hardware

The USB key (also known as a USB flash drive) is packaged with the publications and contains the initialization tool for performing the initial system configuration.

Step 3. Verifying environmental requirements

Certain requirements for the physical site must be met to ensure that your system works reliably. This step includes verifying that adequate space in a suitable rack is available and that requirements for power and environmental conditions are met. This documentation assumes that you have completed the physical planning for the environment of your system.

If you have not done the environmental planning for your system, see the “Storwize V7000 physical installation planning topic” in the Storwize V7000 Information Center.

- | If your system contains more than one control enclosure, you must configure the Fibre Channel switch for correct zoning between the control enclosures. See the configuring topics in the Storwize V7000 Information Center that contain information about zoning rules and zoning details.

You must use a supported web browser. Verify that you are using a supported web browser from the following website:

Support for Storwize V7000 website at www.ibm.com/storage/support/storwize/v7000

1. From the **Search support** input field, type browser.

2. You are shown a search result for “IBM Storwize V7000 Supported Hardware List, Device Driver, Firmware and Recommended Software Levels.” Click the search entry.
3. Scroll down to the “Other Hardware and Software” section.
4. Click “Management GUI.”

Step 4. Reviewing enclosure location guidelines

Use these guidelines to create a plan that identifies an appropriate location in the rack for the enclosure or enclosures that you are installing now or in the future. An enclosure requires two standard rack units of space in a rack. See Figure 9 on page 12 for a sample template of two rack units.

If you are installing a control enclosure only, follow these guidelines:

Position the enclosure in the rack so that you can easily view it and access it for servicing. This action helps the rack to remain stable and provides a way for two or more people to install and remove the enclosure.

If you are installing one control enclosure plus one or more expansion enclosures, follow these guidelines:

If you have one or more expansion enclosures, position the control enclosure in the middle of the expansion enclosures. Balance the expansion enclosures above and below the control enclosure.

For example, position the control enclosure in the middle of the enclosures for ease of cabling.

- You can have no more than five expansion enclosures attached to SAS port 1 of the control enclosure.
- You can have no more than four expansion enclosures attached to SAS port 2 of the control enclosure.
- Position the enclosures together; avoid adding other equipment between enclosures.
- When you add the first expansion enclosure to a control enclosure, it is preferable to add the enclosure directly below the control enclosure.
- When you add a second expansion enclosure, it is preferable to add the enclosure directly above the control enclosure. For each additional expansion enclosure that you add, alternately add it below or above the control enclosure.
- Position the enclosures in the rack so that you can easily view them and access them for servicing. This action helps the rack to remain stable and provides a way for two or more people to install and remove the enclosures.

If you are installing an expansion enclosure to an existing system, follow these guidelines:

When you add the first expansion enclosure to a control enclosure, it is preferable to add the enclosure directly below the control enclosure. When you add a second expansion enclosure, it is preferable to add the enclosure directly above the control enclosure. For each expansion enclosure that you add, alternately add it below or above the control enclosure.

If you are adding an expansion enclosure to an existing system, you do not need to power off the system. You can add an expansion enclosure while the system is operational.

| If you are installing more than one control enclosure, follow these guidelines:

- | If you plan to add more than one set of a control enclosure and expansion enclosures, put the second set of enclosures above the first set of enclosures. Review the guidelines for “If you are installing a control enclosure plus one or more expansion enclosures.” You can also add the second set of enclosures in a different rack.

- | **Note:** When you perform the installation of the enclosures, load the rack from the bottom to ensure rack stability. Empty the rack from the top down.

- | If you are adding another control enclosure to an existing system, you do not need to power off the system. You can add the control enclosure while the system is operational.

Chapter 2. Performing the hardware installation

You have completed the initial steps of verifying the shipping contents and becoming familiar with the hardware components. You have verified that the power and environmental requirements are met and have planned the location of the enclosures. You are now ready to begin installing the hardware components and connecting the data cables and power cords.

Step 5. Installing the support rails

To install the support rails, perform the following steps:

1. Locate the rack mounting rails and screws.

The rail assembly is made up of two sets of rails. One set of rails is already installed, or preinstalled, on the sides of the enclosures. The other set of rails must be installed in the rack cabinet. The rails on the sides of the enclosures slide into the rails that are installed in the rack cabinet.

2. Working at the front of the rack cabinet, identify the two standard rack units of space in the rack into which you want to install the support rails.

Figure 8 shows two rack units with the front mounting holes identified.

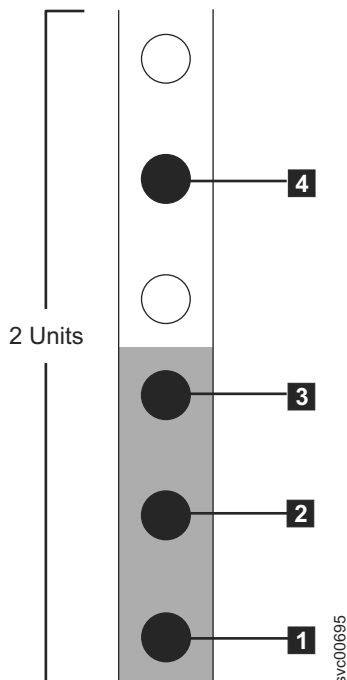

Figure 8. Hole locations in the front of the rack

- **1** Bottom rail location pin hole
 - **2** Enclosure mounting screw hole
 - **3** Rack mounting screw hole
 - **4** Top rail location pin hole
3. Align the bottom of the rail with the bottom of the two rack units. Insert the rail location pins **1** through the holes in the rack cabinet.
 4. Insert a clamping screw into the rack mounting hole **2** between the rail location pins.
 5. Tighten the screw to secure the rail to the rack.

- Working from the rear of the rack cabinet, extend the rail that you secured to the front to align the bottom of the rail with the bottom of the two rack units.

Note: Ensure that the rail is level between the front and the back.

Figure 9 shows two rack units with the back mounting holes identified.

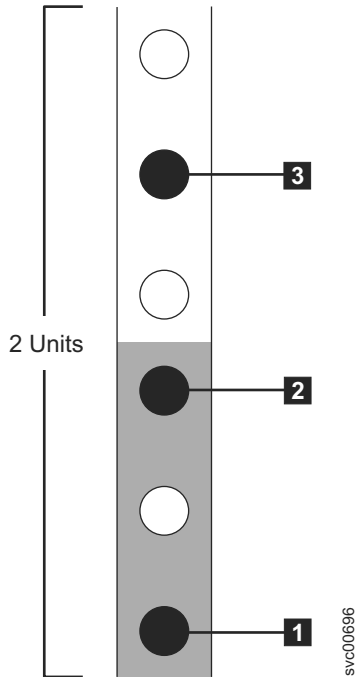

Figure 9. Hole locations in the back of the rack

- **1** Bottom rail location pin hole
 - **2** Rack mounting screw hole
 - **3** Top rail location pin hole
- Insert the rail location pins through the holes in the rack cabinet.
 - Insert a clamping screw into the rack mounting hole between the rail location pins.
 - Tighten the screw to secure the rail to the rack from the back side.
 - Repeat the steps to secure the opposite rail to the rack cabinet.
 - Repeat the procedure for each additional enclosure.

Step 6. Installing the enclosures

CAUTION:

- To lift and install the enclosure into the rack requires at least two people.
- Load the rack from the bottom to ensure rack stability. Empty the rack from the top down.

Following your enclosure location plan, install the correct type of enclosure starting from the bottom.

- On either side of the drive assemblies, remove the enclosure end caps by squeezing the middle of the cap and pulling it away from the front of the enclosure .
- Align the enclosure with the front of the rack cabinet.
- Carefully slide the enclosure into the rack along the rails until the enclosure is fully inserted.

Notes:

- a. The preinstalled rails on the sides of the enclosure must fit into the rack-mounted rails that you previously installed.
 - b. The rails are not designed to hold an enclosure that is partially inserted. The enclosure must always be in a fully inserted position.
 - c. Do not have more than one enclosure extended out of the rack at the same time to avoid the danger of the rack toppling over.
4. Insert a screw into the hole behind each enclosure end cap and tighten the screw.
 5. Push the end caps back into position.
 6. Repeat this procedure for each additional enclosure that you install.

Step 7. Connecting the SAS cables to the expansion enclosures

This task applies if you are installing one or more expansion enclosures.

Note: The enclosure terminology that is used in this topic is described fully in “Step 2. Identifying the hardware components” on page 4.

Be aware of these guidelines when you begin to attach the cables to the SAS ports:

- No more than five expansion enclosures can be chained to port 1 (below the control enclosure). The connecting sequence from port 1 of the node canister is called chain 1.
- No more than four expansion enclosures can be chained to port 2 (above the control enclosure). The connecting sequence from port 2 of the node canister is called chain 2.
- No cable can be connected between a port on an upper canister and a port on a lower canister.
- Attach cables serially between enclosures; do not skip an enclosure.
- The last enclosure in a chain must not have cables in port 2 of canister 1 and port 2 of canister 2.
- Ensure that cables are installed in a tidy manner to reduce the risk of cable damage when Storwize V7000 replaceable units are removed or inserted.
- Arrange your cables to provide access to:
 - The USB ports. Access is required to this port when you use the USB key to configure the system.
 - The enclosures themselves. Access is required to the hardware for servicing and for safely removing and replacing components using two or more people.
- Ensure that each SAS cable is fully inserted. A click is heard when the cable is successfully inserted.

Note: If you make a mistake during cabling and must unplug a SAS cable, pull the blue tag to release the cable.

1. Review Table 2 and the following figures before attaching the SAS cables.

Table 2 provides a summary of how to attach the SAS cables.

Table 2. Cabling guide

From:	To:
1 Port 1 of upper canister, control enclosure	2 Port 1 of upper canister, expansion enclosure 1
3 Port 1 of lower canister, control enclosure	4 Port 1 of lower canister, expansion enclosure 1
5 Port 2 of upper canister, control enclosure	6 Port 1 of upper canister, expansion enclosure 2
7 Port 2 of lower canister, control enclosure	8 Port 1 of lower canister, expansion enclosure 2
9 Port 2 of upper canister, expansion enclosure 1	10 Port 1 of upper canister, expansion enclosure 3
11 Port 2 of lower canister, expansion enclosure 1	12 Port 1 of lower canister, expansion enclosure 3

2. Attach the SAS cables from the control enclosure to the first expansion enclosure as shown in Figure 10 on page 14. Remove the protective end covers, if necessary. The first expansion enclosure is

below the control enclosure.

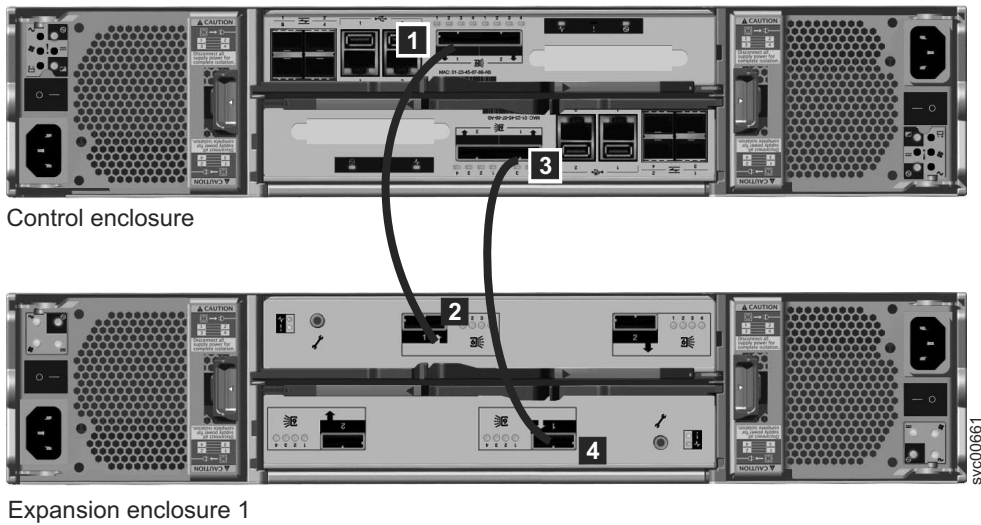

Figure 10. Attaching an expansion enclosure to the control enclosure

- a. Port 1 **1** of the upper canister, control enclosure, attaches to Port 1 **2** of the upper canister, expansion enclosure 1.
- b. Port 1 **3** of the lower canister, control enclosure, attaches to Port 1 **4** of the lower canister, expansion enclosure 1. The port locations on the lower canister are inverted from the port locations on the upper canister. Port 1 on the lower canister is opposite port 1 on the upper canister.

Note: The connecting sequence from port 1 of the node canister is called chain 1.

- 3. Attach the SAS cables from the control enclosure to the second expansion enclosure as shown in Figure 11 on page 15. The second expansion enclosure is above the control enclosure.

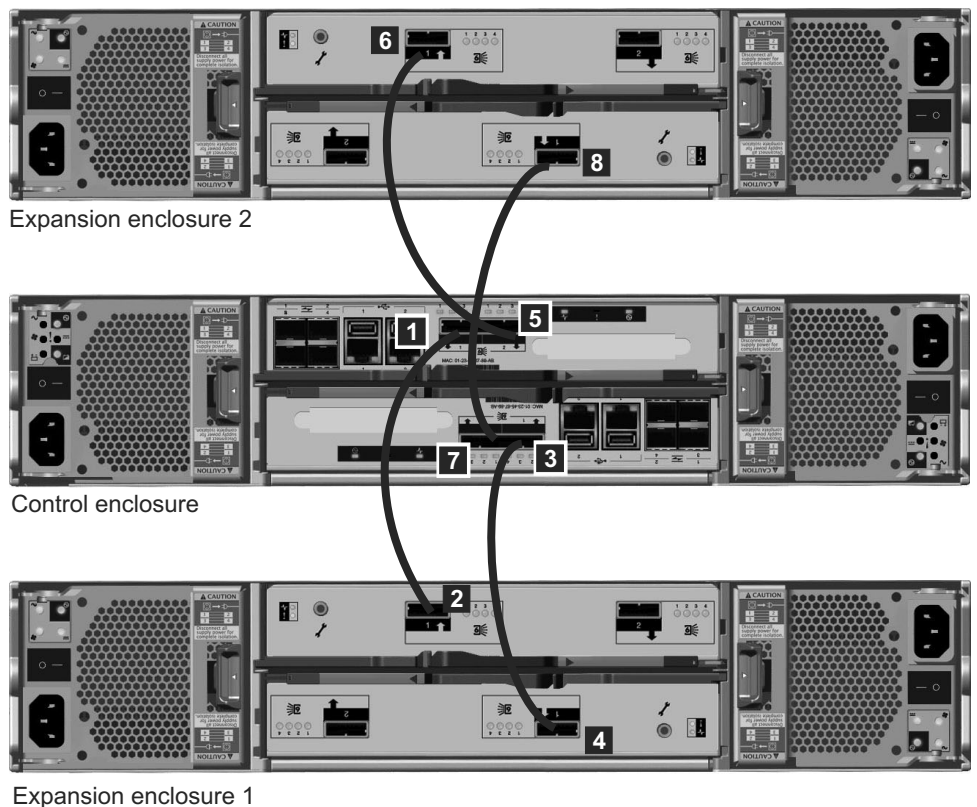

Figure 11. Adding a second expansion enclosure

- a. Port 2 **5** of the upper canister, control enclosure, attaches to Port 1 **6** of the upper canister, expansion enclosure 2.
- b. Port 2 **7** of the lower canister, control enclosure, attaches to Port 1 **8** of the lower canister, expansion enclosure 2. The port locations on the lower canister are inverted from the port locations on the upper canister. Port 1 on the lower canister is opposite port 1 on the upper canister.

Note: The connecting sequence from port 2 of the node canister is called chain 2.

4. Attach the SAS cables from the first expansion enclosure to the third expansion enclosure.

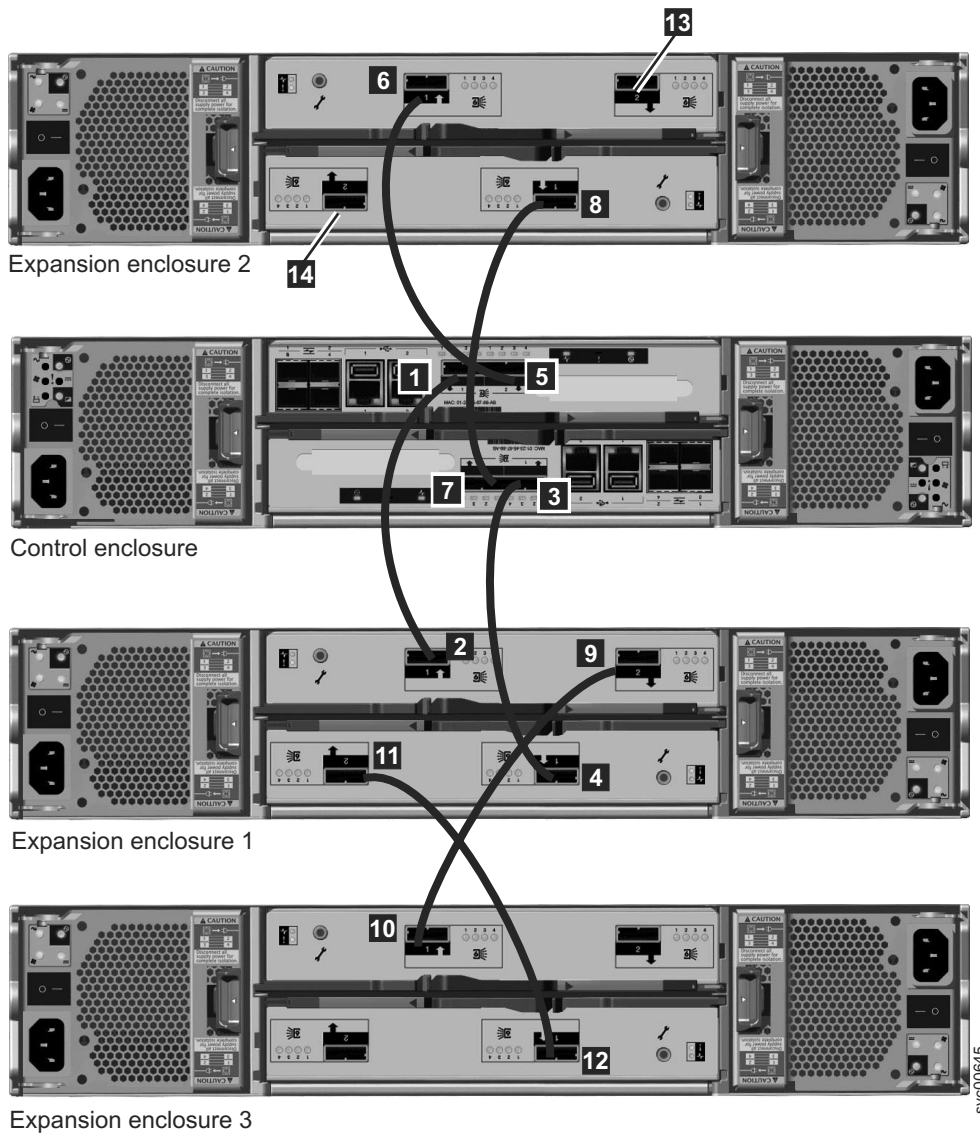

Figure 12. Attaching SAS cables to the enclosures

- a. Port 2 **9** of the upper canister, expansion enclosure 1, attaches to Port 1 **10** of the upper canister, expansion enclosure 3.
- b. Port 2 **11** of the lower canister, expansion enclosure 1, attaches to Port 1 **12** of the lower canister, expansion enclosure 3.
- 5. Attach SAS cables for additional expansion enclosures. You can add up to nine expansion enclosures. You add a fourth expansion enclosure at **13** and **14** on expansion enclosure 2.
 - a. Add the enclosures alternately to chain 1, and then chain 2.
 - b. Use port 2 on the canisters that are already connected to attach to port 1 on the canisters of the enclosures that you want to add.
 - c. Connect the SAS cables from canister 1 to canister 1.
 - d. Connect the SAS cables from canister 2 to canister 2.
- 6. Verify your cabling.

Step 8. Attaching the Ethernet cables

This task applies if you are installing a control enclosure only or a control enclosure plus one or more expansion enclosures.

This task assumes that your initial planning has determined where the Ethernet cables are to be located.

- | **Attention:** The default service IP addresses on your new node canisters might conflict with existing devices that are attached to the network or with other new control enclosures that you are installing.
- | If you encounter that situation, change the service IP addresses on the new nodes before connecting the Ethernet cables. For details on how to do this, see “Setting up your system for the first time with a control enclosure or a control enclosure and one or more expansion enclosures” on page 23 or see the *IBM Storwize V7000 Troubleshooting, Recovery, and Maintenance Guide* PDF on the DVD for further information about setting service IP addresses using a USB key.
- | When you install multiple control enclosures, you increase the chance of conflicts in IP addresses.

To attach the Ethernet cables, perform the following steps:

1. For each node canister in the control enclosure, connect an Ethernet cable between Ethernet port 1 of the canister and an enabled port on your Ethernet switch or router. Port 1 can be used for management, service, and iSCSI.

Note: Ethernet cables are not supplied as part of your order. A CAT 5 unshielded twisted pair (UTP) is the minimum requirement for an Ethernet cable.

Ensure that cables are installed in a tidy manner to reduce the risk of cable damage when Storwize V7000 replaceable units are removed or inserted.

2. Optionally attach Ethernet cables between Ethernet port 2 on each node canister and your Ethernet network. Port 2 can be used for management and iSCSI.

Step 9. Attaching the Fibre Channel longwave SFP transceivers

- | This task applies if you ordered Fibre Channel longwave SFP transceivers.

Attention: The shortwave SFP transceivers are preinstalled in the control enclosure. No further action is required if you are using the shortwave SFP transceivers.

To attach the SFP transceivers, perform the following steps:

1. For both node canisters in the control enclosure, identify which of the four shortwave SFP transceivers must be replaced with longwave SFP transceivers.
2. Remove the shortwave SFP transceivers.
3. Plug the longwave SFP transceivers into ports 1-4, as needed.

For more information about removing and replacing hardware components, see the “Removing and replacing parts” topics in the Storwize V7000 Information Center to find out how to perform these procedures.

Step 10. Attaching the Fibre Channel cables

This task applies if you are installing a control enclosure and are connecting it to your Fibre Channel network.

This task assumes that your initial planning has determined where the Fibre Channel cables are to be located.

To attach the Fibre Channel cables, perform the following steps:

1. Remove any protective end covers from the cables or the SFP transceivers.
2. Attach the Fibre Channel cables to a Fibre Channel switch.
Ensure that cables are installed in a tidy manner to reduce the risk of cable damage when Storwize V7000 replaceable units are removed or inserted.
3. Attach the other ends of the Fibre Channel cables to the Fibre Channel ports on the node canisters.

Note: If you use fewer than eight Fibre Channel cables, it does not matter which Fibre Channel ports you use. Ensure that you attach the Fibre Channel cables evenly between the two node canisters.

After you have started your system, be sure to configure your Fibre Channel zoning to match the guidelines in the “Zoning details” topic in the Storwize V7000 Information Center.

Notes:

1. Ensure that Storwize V7000 ports with shortwave SFP transceivers are connected to shortwave SFP transceivers on the Fibre Channel switch.
2. Ensure that Storwize V7000 ports with longwave SFP transceivers are connected to longwave SFP transceivers on the Fibre Channel switch.
3. The cable types are different between longwave and shortwave connections. Ensure that the correct cable type is used.

Step 11. Attaching the 10 Gbps Ethernet cables

This task applies if you are installing a model type 2076-312 or a model type 2076-324 that has the 10 Gbps Ethernet ports.

This task assumes that your initial planning has determined where the Ethernet optical cables are to be located.

To attach the optical cables, perform the following steps:

1. Remove any protective end covers from the cables or the SFP transceivers.
2. Attach the Ethernet optical cables to ports on a 10 Gbps Ethernet switch.
Ensure that cables are installed in a tidy manner to reduce the risk of cable damage when Storwize V7000 replaceable units are removed or inserted.
3. Attach the other ends of the Ethernet optical cables to the 10 Gbps Ethernet ports on the node canisters.
See Figure 5 on page 7 for the port locations.

Important: For each set of canisters, connect the Ethernet ports with the same numbers to the same subnets so that the failover of system management and iSCSI IP addresses can occur between canisters. For example, canister 1, port 1, must be on the same subnet as canister 2, port 1, and canister 1, port 3, must be on the same subnet as canister 2, port 3.

Step 12. Connecting the power cords

Two power supply units are located in each enclosure. Ensure that the power switches for each power supply unit are off.

Note: Each power supply unit comes with an attached cable retention bracket that fastens around the power cord to prevent the cord from being removed accidentally.

Perform the following steps when you attach the power cord to each power supply unit:

1. Straighten the cable tie on the cable retention bracket. The cable retention bracket is attached to the power supply unit.
2. Open the cable retention bracket.
3. Slide the cable retention bracket away from the power supply unit until there is enough room to attach the cable retention bracket to the cable. When sliding the bracket away from the cable plugin, pull the lever on the bracket that controls the cable tie slightly towards the center of the canister. You do not need to pull the lever to slide the bracket towards the cable plugin.
4. Attach a power cord to each of the two power supply units in each enclosure.
Ensure that cables are installed in a tidy manner to reduce the risk of cable damage when Storwize V7000 replaceable units are removed or inserted.
5. Place the cable retention bracket around the end of the cable that plugs into the power supply unit.
6. Slide the cable retention bracket along the cord until it fits snugly against the plug end of the cable.
7. Tighten the fastener around the plug.
8. Repeat the steps for each additional power cord.
9. Plug the power cords into a properly grounded electrical outlet. To provide power failure redundancy, plug the power cords for the individual power supply units for each enclosure into separate power distribution circuits, if possible.

Step 13. Powering on the system

Attention: Do not operate the system when the drive assemblies are missing. Drive assemblies that are missing disrupt the airflow; the drives do not receive sufficient cooling. You must insert blank carriers into unused drive bays.

This topic is divided into two procedures; the first one, powering on an expansion enclosure; the second one, powering on a control enclosure.

Powering on an expansion enclosure:

1. Power on the newly installed enclosures. Use the power switch on each of the two power supply units in the back of the expansion enclosure.
2. Use the information in Table 3 on page 20 to verify the state of the LEDs on the system. Verify that no faults are detected. See the *IBM Storwize V7000 Troubleshooting, Recovery, and Maintenance Guide* PDF on the DVD if problems are encountered.

Figure 13 on page 20 shows the location of the LEDs on the power supply units in the rear of the expansion enclosure.

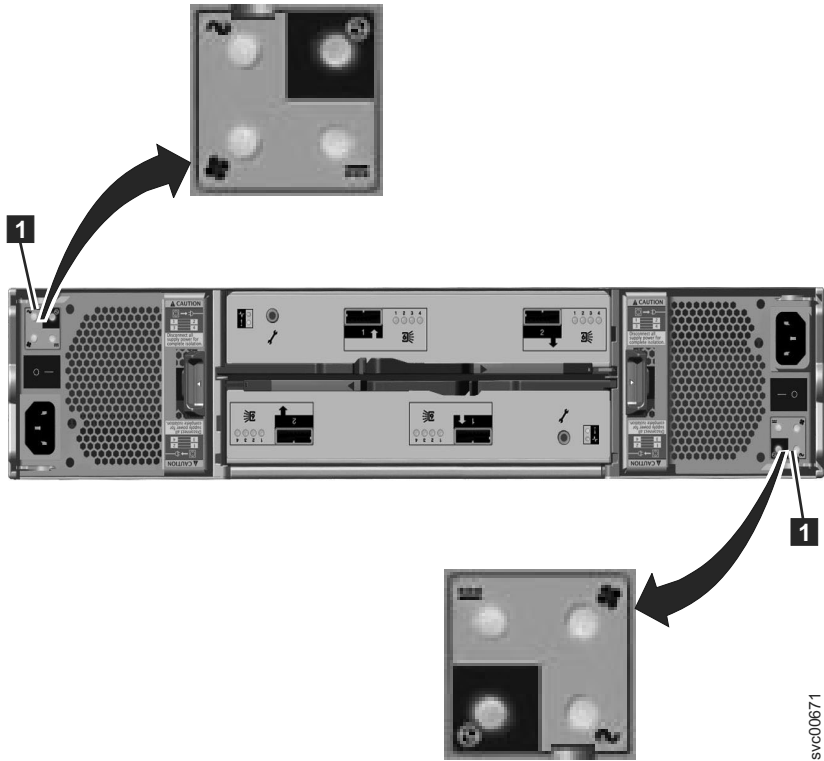











Figure 13. LEDs on the power supply units of the expansion enclosure

Table 3. LED status when expansion enclosures are powered on

Hardware component	LED name and symbol	If power on and no fault is detected
Left enclosure end cap, front of enclosure	Power, top 	LED is on.
	Fault, middle 	LED is off.
	Identify, bottom 	LED is off.
Expansion canister, rear. The reference to the top and bottom locations applies to canister 1, which is the upper canister. The LED locations are inverted for canister 2, which is the lower canister.	Canister status, top 	LED is on.
	Fault status, bottom 	LED is off.
Power supply unit, expansion enclosure. The reference to the left and right locations applies to power supply unit 1, which is the left power supply. The LED locations are inverted for power supply unit 2, which is the right power supply.	Power supply, upper right 	LED is on.
	Fan failure 	LED is off.
	dc power failure 	LED is off.
	ac power failure, upper left 	LED is off.

Powering on a control enclosure:

1. Power on the control enclosure, if it is not already powered on and configured, by using the power switch on each of the two power supply units in the back of the enclosure.
2. Use the Table 4 on page 21 to verify the state of the LEDs on the system. Verify that no faults are detected.

Figure 14 shows the location of the LEDs on the power supply units in the rear of the control enclosure.

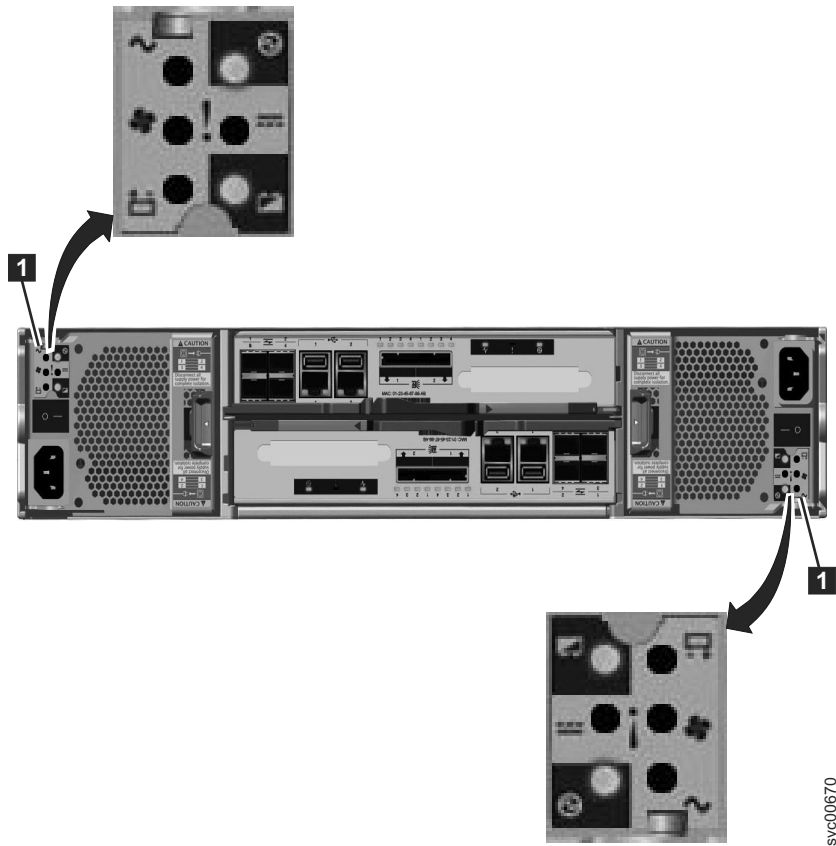









svc00670

Figure 14. LEDs on the power supply units of the control enclosure

Table 4. LED status when control enclosure is powered on

Hardware component	LED name	If power on and no fault is detected
Left enclosure end cap, front of enclosure	Power, top ⏻	LED is on.
	Fault, middle !	LED is off.
	Identify, bottom 🔊	LED is off.

Table 4. LED status when control enclosure is powered on (continued)

Hardware component	LED name	If power on and no fault is detected
Node canister, rear. The reference to the top and bottom locations applies to canister 1, which is the upper canister. The LED locations are inverted for canister 2, which is the lower canister.	Fibre Channel port, if used	One or more LEDs are on or flashing per port. The LEDs are located between the Fibre Channel ports. The arrow-shaped LEDs point toward the affected port.
	Ethernet port, if used	One or more LEDs are on per port.
	SAS ports	When a SAS port is functioning correctly, all four green LEDs above the port are on. If no cable is plugged into the port, or if the canister at either end of the cable is not yet fully started, the LEDs are not on.
	System status, left 	LED is flashing or on. The status is on if the node canister is an active member of a clustered system. The LED is flashing if the node canister is in service or candidate state. If the LED is off, the node canister might still be booting up. Wait up to 5 minutes for the node canister to complete booting up.
	Fault status, middle 	LED is off.
	Power status, right 	LED is on.
Power supply unit, control enclosure. The reference to the left and right locations applies to power supply unit 1, which is the left power supply. The LED locations are inverted for power supply unit 2, which is the right power supply.	Power supply, upper right 	LED is on.
	ac power failure, upper left 	LED is off.
	dc power failure 	LED is off.
	Fan failure 	LED is off.
	Battery failure 	LED is off
	Battery good, lower right 	LED is on or flashing.

Attention: Do not go to the next section until the LEDs are in the required states.

See the *IBM Storwize V7000 Troubleshooting, Recovery, and Maintenance Guide* PDF on the DVD if problems are encountered.

Chapter 3. Configuring the system

In the previous steps, you installed the enclosures in the rack, connected all cables, powered the system on, and checked the LED status for the system. When you have completed all these steps, continue with the last step to configure the system.

The last step for configuring your system provides instructions for several scenarios:

- Setting up your system for the first time.
- Adding one or more expansion enclosures to an existing system.
- Adding another control enclosure to an existing system.

Setting up your system for the first time with a control enclosure or a control enclosure and one or more expansion enclosures

To complete this step, you must use a supported web browser. Verify that you are using a supported web browser from the following website:

Support for Storwize V7000 website at www.ibm.com/storage/support/storwize/v7000

You must initialize the system by creating a clustered system and configuring it. The first stage is to create the clustered system using the initialization tool and the USB key. You must know the required IP management address that is assigned to the system before continuing.

1. Locate the USB key that was shipped with your order in the documentation package.

| **Note:** You might encounter a problem where the code cannot be run if you use your own USB key.
| The USB key that you use must:

- | • Contain a FAT32 formatted file system on its first partition; for example, NTFS is not a supported type.
- | • Contain a copy of the Microsoft Windows USB key `InitTool.exe` executable that is located in the root directory of the file system.
- | • Be write enabled.

2. Insert the USB key into a USB port in a personal computer that is running Microsoft Windows XP Professional or higher.

Start the initialization tool.

If the system is configured to autorun for USB keys, the initialization tool starts automatically. Otherwise, open the USB key from **My Computer** and double-click the `InitTool.exe`.

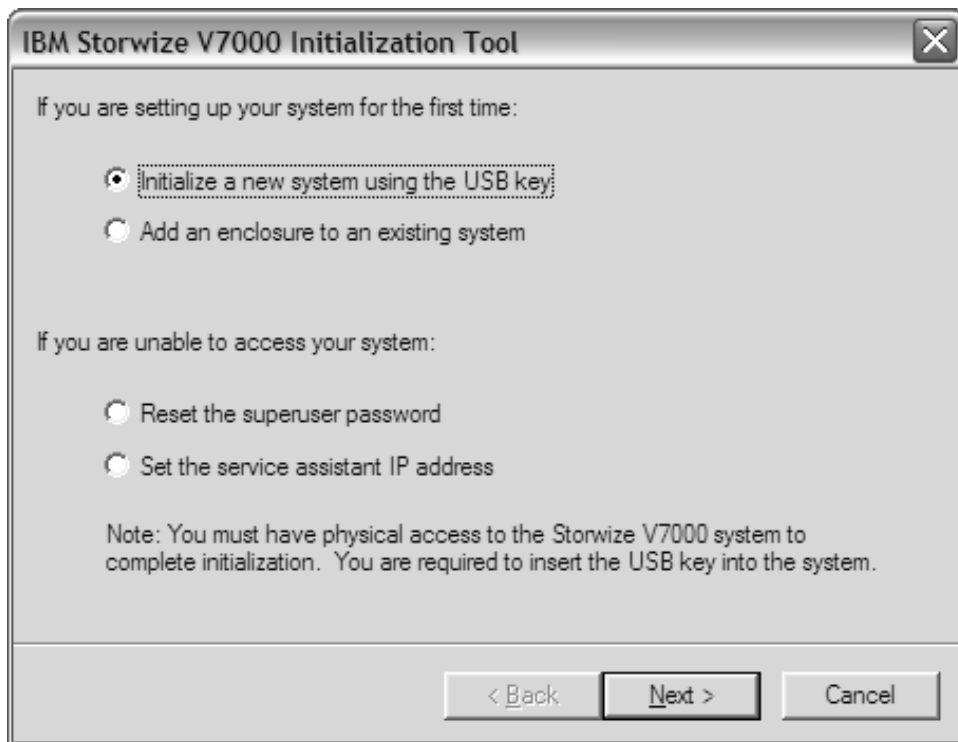

Figure 15. Initialization tool welcome panel

If you are running a non-Windows operating system, you must create the files manually on the USB key. See the *IBM Storwize V7000 Troubleshooting, Recovery, and Maintenance Guide* PDF on the DVD to learn more about using the USB key to manage or service the system.

3. Follow the on-screen instructions to configure the system by selecting the **Initialize a new system using the USB key** option from the Welcome panel of the initialization tool. The initialization tool guides you through the configuration process:
 - a. Entering the management IP address.
 - b. Transferring the USB key to the powered-on control enclosure to create the clustered system. Do not insert the USB key until the node canister has completed booting up.

While the clustered system is being created, the amber fault LED on the node canister flashes. When the amber fault LED stops flashing, remove the USB key and reinsert it in your personal computer to restart the initialization tool. The results of the create clustered system operation are shown. Check that the create operation succeeded.

The system cannot become active until there is sufficient battery power to safeguard the system in the event of a power failure. If the batteries do not have sufficient charge, the system cannot start immediately. An estimated time for when the system is available is shown. When you receive the batteries, they normally contain sufficient power for the system to start.

The LED status on the node canisters in the control enclosure change when a clustered system starts. The status LED on the node canister that you created the clustered system on changes from flashing to fully on when the clustered system is created and there is sufficient battery power to safeguard the system. After a short wait, the status LED on the other node canister changes from flashing to fully on. For information about the LEDs, see “Step 13. Powering on the system” on page 19.

If necessary, wait until the system has started.

If you are unable to create the clustered system, see the *IBM Storwize V7000 Troubleshooting, Recovery, and Maintenance Guide* PDF on the DVD that is shipped with the system. Remove hardware components only when directed to do so by the fix procedures. Failure to follow the procedures can result in loss of access to data or loss of data.

4. If the personal computer from which you are using the initialization tool has a supported browser and an Ethernet connection to the management IP address that is assigned to the system, click **Launch the management GUI** on the results window. Otherwise, go to a personal computer that has an Ethernet connection to the management IP address and point a supported browser to the management IP address to start the management GUI. You see the management GUI logon panel.

If you are unable to start the management GUI or encounter other problems, see the *IBM Storwize V7000 Troubleshooting, Recovery, and Maintenance Guide* PDF on the DVD that is shipped with the system.

5. Log in as superuser. Use password for the password.

Note: Change the password to a secure value as soon as possible.

6. Review the International Program License Agreement (IPLA).
You must accept the agreement before you can continue to use the product.
7. The Setup wizard starts and guides you through the initial configuration and verification of the system.

If you are not ready to complete any of the configuration steps now, use the configuration tasks in the management GUI to complete the configuration at a later time.

8. When you are finished using the USB key, store it in a safe location. You can use it to do other tasks.

This step completes the quick installation procedures. If you are setting up for the first time, see the configuring topics in the Storwize V7000 Information Center and continue to follow the tasks available in **Getting Started** from the management GUI.

Adding an expansion enclosure into an existing system

To complete this step, you must use a supported web browser. Verify that you are using a supported web browser from the following website:

Support for Storwize V7000 website at www.ibm.com/storage/support/storwize/v7000

To add an expansion enclosure into an existing system, perform the following steps:

1. Start the management GUI.
2. Go to **Home > Manage Device**.
3. Select the system name in the tree.
4. Go to **Actions > Add Enclosures > Expansion only**.
5. Continue to follow the on-screen instructions.

This step completes the quick installation procedures. Now that you have added an expansion enclosure into an existing system, continue to perform your standard tasks.

Adding another control enclosure into an existing system

To complete this step, you must use a supported web browser. Verify that you are using a supported web browser from the following website:

Support for Storwize V7000 website at www.ibm.com/storage/support/storwize/v7000

Note: When you add another control enclosure, you do not use the initialization tool or the USB key.

To add another control enclosure into an existing system, perform the following steps:

1. Configure the Fibre Channel switch to allow for correct zoning between the control enclosures.

| The correct zoning provides a way for the Fibre Channel ports to connect to each other. See the
| configuring topics in the Storwize V7000 Information Center that contain information about zoning
| rules and zoning details.

| If the configuration tool for the Fibre Channel switch does not provide details of the world wide port
| names (WWPNs), use the service assistant to find them or use the USB key to find the status of the
| node. For information about the status of the node, see the *IBM Storwize V7000 Troubleshooting,
| Recovery, and Maintenance Guide* PDF on the DVD that is shipped with the system.

- | 2. Start the management GUI.
- | 3. Go to **Home > Manage Device**.
- | 4. Select the system name in the tree.
- | 5. Go to **Actions > Add Enclosures > Control and Expansions**.
- | 6. Continue to follow the on-screen instructions.

| This step completes the quick installation procedures. If you are setting up for the first time, see the
| configuring topics in the Storwize V7000 Information Center and continue to follow the tasks available in
| **Getting Started** from the management GUI. If you added an expansion enclosure into an existing system,
| continue to perform your standard tasks.

Notices

This information was developed for products and services offered in the U.S.A.

IBM may not offer the products, services, or features discussed in this document in other countries. Consult your local IBM representative for information on the products and services currently available in your area. Any reference to an IBM product, program, or service is not intended to state or imply that only that IBM product, program, or service may be used. Any functionally equivalent product, program, or service that does not infringe any IBM intellectual property right may be used instead. However, it is the user's responsibility to evaluate and verify the operation of any non-IBM product, program, or service.

IBM may have patents or pending patent applications covering subject matter described in this document. The furnishing of this document does not give you any license to these patents. You can send license inquiries, in writing, to:

*IBM Director of Licensing
IBM Corporation
North Castle Drive
Armonk, NY 10504-1785
U.S.A.*

For license inquiries regarding double-byte (DBCS) information, contact the IBM Intellectual Property Department in your country or send inquiries, in writing, to:

*Intellectual Property Licensing
Legal and Intellectual Property Law
IBM Japan, Ltd.
1623-14, Shimotsuruma, Yamato-shi
Kanagawa 242-8502 Japan*

The following paragraph does not apply to the United Kingdom or any other country where such provisions are inconsistent with local law: INTERNATIONAL BUSINESS MACHINES CORPORATION PROVIDES THIS PUBLICATION "AS IS" WITHOUT WARRANTY OF ANY KIND, EITHER EXPRESS OR IMPLIED, INCLUDING, BUT NOT LIMITED TO, THE IMPLIED WARRANTIES OF NON-INFRINGEMENT, MERCHANTABILITY OR FITNESS FOR A PARTICULAR PURPOSE. Some states do not allow disclaimer of express or implied warranties in certain transactions, therefore, this statement may not apply to you.

This information could include technical inaccuracies or typographical errors. Changes are periodically made to the information herein; these changes will be incorporated in new editions of the publication. IBM may make improvements and/or changes in the product(s) and/or the program(s) described in this publication at any time without notice.

Any references in this information to non-IBM websites are provided for convenience only and do not in any manner serve as an endorsement of those websites. The materials at those websites are not part of the materials for this IBM product and use of those websites is at your own risk.

IBM may use or distribute any of the information you supply in any way it believes appropriate without incurring any obligation to you.

Licensees of this program who wish to have information about it for the purpose of enabling: (i) the exchange of information between independently created programs and other programs (including this one) and (ii) the mutual use of the information which has been exchanged, should contact:

*IBM Corporation
Almaden Research
650 Harry Road
Bldg 80, D3-304, Department 277
San Jose, CA 95120-6099
U.S.A.*

Such information may be available, subject to appropriate terms and conditions, including in some cases, payment of a fee.

The licensed program described in this document and all licensed material available for it are provided by IBM under terms of the IBM Customer Agreement, IBM International Program License Agreement or any equivalent agreement between us.

Any performance data contained herein was determined in a controlled environment. Therefore, the results obtained in other operating environments may vary significantly. Some measurements may have been made on development-level systems and there is no guarantee that these measurements will be the same on generally available systems. Furthermore, some measurement may have been estimated through extrapolation. Actual results may vary. Users of this document should verify the applicable data for their specific environment.

Information concerning non-IBM products was obtained from the suppliers of those products, their published announcements or other publicly available sources. IBM has not tested those products and cannot confirm the accuracy of performance, compatibility or any other claims related to non-IBM products. Questions on the capabilities of non-IBM products may be addressed to the suppliers of those products.

All statements regarding IBM's future direction or intent are subject to change or withdrawal without notice, and represent goals and objectives only.

This information is for planning purposes only. The information herein is subject to change before the products described become available.

This information contains examples of data and reports used in daily business operations. To illustrate them as completely as possible, the examples include the names of individuals, companies, brands, and products. All of these names are fictitious and any similarity to the names and addresses used by an actual business enterprise is entirely coincidental.

COPYRIGHT LICENSE:

This information contains sample application programs in source language, which illustrate programming techniques on various operating platforms. You may copy, modify, and distribute these sample programs in any form without payment to IBM, for the purposes of developing, using, marketing or distributing application programs conforming to the application programming interface for the operating platform for which the sample programs are written. These examples have not been thoroughly tested under all conditions. IBM, therefore, cannot guarantee or imply reliability, serviceability, or function of these programs. The sample programs are provided "AS IS", without warranty of any kind. IBM shall not be liable for any damages arising out of your use of the sample programs.

If you are viewing this information softcopy, the photographs and color illustrations may not appear.

Trademarks

IBM, the IBM logo, and ibm.com are trademarks or registered trademarks of International Business Machines Corp., registered in many jurisdictions worldwide. Other product and service names might be trademarks of IBM or other companies. A current list of IBM trademarks is available on the web at Copyright and trademark information at www.ibm.com/legal/copytrade.shtml.

Adobe and the Adobe logo are either registered trademarks or trademarks of Adobe Systems Incorporated in the United States, and/or other countries.

Intel, Intel logo, Intel Xeon, and Pentium are trademarks or registered trademarks of Intel Corporation or its subsidiaries in the United States and other countries.

Linux is a registered trademark of Linus Torvalds in the United States, other countries, or both.

Microsoft, Windows, Windows NT, and the Windows logo are trademarks of Microsoft Corporation in the United States, other countries, or both.

UNIX is a registered trademark of The Open Group in the United States and other countries.

Java and all Java-based trademarks and logos are trademarks or registered trademarks of Oracle and/or its affiliates.

Other product and service names might be trademarks of IBM or other companies.

Electronic emission notices

The following electronic emission statements apply to this product. The statements for other products that are intended for use with this product are included in their accompanying documentation.

Federal Communications Commission (FCC) statement

This explains the Federal Communications Commission's (FCC) statement.

This equipment has been tested and found to comply with the limits for a Class A digital device, pursuant to Part 15 of the FCC Rules. These limits are designed to provide reasonable protection against harmful interference when the equipment is operated in a commercial environment. This equipment generates, uses, and can radiate radio frequency energy and, if not installed and used in accordance with the instruction manual, might cause harmful interference to radio communications. Operation of this equipment in a residential area is likely to cause harmful interference, in which case the user will be required to correct the interference at his own expense.

Properly shielded and grounded cables and connectors must be used in order to meet FCC emission limits. IBM is not responsible for any radio or television interference caused by using other than recommended cables and connectors, or by unauthorized changes or modifications to this equipment. Unauthorized changes or modifications could void the user's authority to operate the equipment.

This device complies with Part 15 of the FCC Rules. Operation is subject to the following two conditions: (1) this device might not cause harmful interference, and (2) this device must accept any interference received, including interference that might cause undesired operation.

Industry Canada compliance statement

This Class A digital apparatus complies with ICES-003.

Cet appareil numérique de la classe A est conforme à la norme NMB-003 du Canada.

Avis de conformité à la réglementation d'Industrie Canada

Cet appareil numérique de la classe A est conforme à la norme NMB-003 du Canada.

Australia and New Zealand Class A Statement

Attention: This is a Class A product. In a domestic environment this product might cause radio interference in which case the user might be required to take adequate measures.

European Union Electromagnetic Compatibility Directive

This product is in conformity with the protection requirements of European Union (EU) Council Directive 2004/108/EC on the approximation of the laws of the Member States relating to electromagnetic compatibility. IBM cannot accept responsibility for any failure to satisfy the protection requirements resulting from a non-recommended modification of the product, including the fitting of non-IBM option cards.

Attention: This is an EN 55022 Class A product. In a domestic environment this product might cause radio interference in which case the user might be required to take adequate measures.

Responsible Manufacturer:

International Business Machines Corp.
New Orchard Road
Armonk, New York 10504
914-499-1900

European community contact:

IBM Technical Regulations, Department M456
IBM-Allee 1, 71137 Ehningen, Germany
Tel: +49 7032 15-2937
E-mail: tjahn@de.ibm.com

Germany Electromagnetic compatibility directive

Deutschsprachiger EU Hinweis: Hinweis für Geräte der Klasse A EU-Richtlinie zur Elektromagnetischen Verträglichkeit

Dieses Produkt entspricht den Schutzanforderungen der EU-Richtlinie 2004/108/EG zur Angleichung der Rechtsvorschriften über die elektromagnetische Verträglichkeit in den EU-Mitgliedsstaaten und hält die Grenzwerte der EN 55022 Klasse A ein.

Um dieses sicherzustellen, sind die Geräte wie in den Handbüchern beschrieben zu installieren und zu betreiben. Des Weiteren dürfen auch nur von der IBM empfohlene Kabel angeschlossen werden. IBM übernimmt keine Verantwortung für die Einhaltung der Schutzanforderungen, wenn das Produkt ohne Zustimmung der IBM verändert bzw. wenn Erweiterungskomponenten von Fremdherstellern ohne Empfehlung der IBM gesteckt/eingebaut werden.

EN 55022 Klasse A Geräte müssen mit folgendem Warnhinweis versehen werden:

"Warnung: Dieses ist eine Einrichtung der Klasse A. Diese Einrichtung kann im Wohnbereich Funk-Störungen verursachen; in diesem Fall kann vom Betreiber verlangt werden, angemessene Maßnahmen zu ergreifen und dafür aufzukommen."

Deutschland: Einhaltung des Gesetzes über die elektromagnetische Verträglichkeit von Geräten

Dieses Produkt entspricht dem "Gesetz über die elektromagnetische Verträglichkeit von Geräten (EMVG)." Dies ist die Umsetzung der EU-Richtlinie 2004/108/EG in der Bundesrepublik Deutschland.

Zulassungsbescheinigung laut dem Deutschen Gesetz über die elektromagnetische Verträglichkeit von Geräten (EMVG) (bzw. der EMC EG Richtlinie 2004/108/EG) für Geräte der Klasse A

Dieses Gerät ist berechtigt, in Übereinstimmung mit dem Deutschen EMVG das EG-Konformitätszeichen - CE - zu führen.

Verantwortlich für die Einhaltung der EMV Vorschriften ist der Hersteller:

International Business Machines Corp.
New Orchard Road
Armonk, New York 10504
Tel: 914-499-1900

Der verantwortliche Ansprechpartner des Herstellers in der EU ist:

IBM Deutschland
Technical Regulations, Department M456
IBM-Allee 1, 71137 Ehningen, Germany
Tel: +49 7032 15-2937
e-mail: tjahn@de.ibm.com

Generelle Informationen: Das Gerät erfüllt die Schutzanforderungen nach EN 55024 und EN 55022 Klasse A.

Japan VCCI Council Class A statement

この装置は、クラス A 情報技術装置です。この装置を家庭環境で使用する
と電波妨害を引き起こすことがあります。この場合には使用者が適切な対策
を講ずるよう要求されることがあります。 VCCI-A

People's Republic of China Class A Electronic Emission Statement

中华人民共和国“A类”警告声明

声明

此为A级产品，在生活环境中，该产品可能会造成无线电干扰。在这种情况下，可能需要用户对其干扰采取切实可行的措施。

International Electrotechnical Commission (IEC) statement

This product has been designed and built to comply with (IEC) Standard 950.

United Kingdom telecommunications requirements

This apparatus is manufactured to the International Safety Standard EN60950 and as such is approved in the U.K. under approval number NS/G/1234/J/100003 for indirect connection to public telecommunications systems in the United Kingdom.

Korean Communications Commission (KCC) Class A Statement

이 기기는 업무용(A급)으로 전자파적합기기로서 판매자 또는 사용자는 이 점을 주의하시기 바라며, 가정외의 지역에서 사용하는 것을 목적으로 합니다.

Russia Electromagnetic Interference (EMI) Class A Statement

ВНИМАНИЕ! Настоящее изделие относится к классу А. В жилых помещениях оно может создавать радиопомехи, для снижения которых необходимы дополнительные меры

rusemi

Taiwan Class A compliance statement

警告使用者：
這是甲類的資訊產品，在居住的環境中使用時，可能會造成射頻干擾，在這種情況下，使用者會被要求採取某些適當的對策。

taiemi

European Contact Information

This topic contains the product service contact information for Europe.

European Community contact:
IBM Technical Regulations
Pascalstr. 100, Stuttgart, Germany 70569
Tele: 0049 (0)711 785 1176
Fax: 0049 (0)711 785 1283
Email: <mailto:tjahn@de.ibm.com>

Taiwan Contact Information

This topic contains the product service contact information for Taiwan.

IBM Taiwan Product Service Contact Information:
IBM Taiwan Corporation
3F, No 7, Song Ren Rd., Taipei Taiwan
Tel: 0800-016-888

台灣IBM 產品服務聯絡方式：
台灣國際商業機器股份有限公司
台北市松仁路7號3樓
電話：0800-016-888

f2c00790



Part Number: 85Y6162

Printed in USA

GC27-2290-01



(1P) P/N: 85Y6162

