

IBM Storwize V7000 Unified

Quick Installation Guide



Note

Before using this information and the product it supports, read the general information in “Notices” on page 77, the information in the “Safety and environmental notices” on page ix, as well as the information in the *IBM Environmental Notices and User Guide* , which is provided on a DVD.

This edition applies to IBM Storwize V7000 Unified and to all subsequent releases and modifications until otherwise indicated in new editions.

This edition replaces GA32-1056-06.

© **Copyright IBM Corporation 2011, 2012.**

US Government Users Restricted Rights – Use, duplication or disclosure restricted by GSA ADP Schedule Contract with IBM Corp.

Contents

Figures	v
--------------------------	----------

Tables	vii
-------------------------	------------

Safety and environmental notices **ix**

Safety	ix
Safety statements	xi
Sound pressure	xv

About this guide **xvii**

Who should use this guide.	xvii
Accessibility	xvii
Emphasis	xvii
Storwize V7000 Unified library and related publications	xviii
How to order IBM publications.	xx
Sending your comments	xxi

Chapter 1. Before you begin the installation **1**

Step 1. Reviewing your packing slip	1
Step 2. Identifying the hardware components	3
Step 3. Verifying environmental requirements	8
Step 4. Reviewing enclosure location guidelines	9
Step 5. Gather information	11
Checking that IP addresses are not already in use	11
Information required before initializing your system	12
Information required before starting initial configuration of your system	15

Chapter 2. Performing the hardware installation **29**

Step 6. Installing the support rails for the enclosures	29
Step 7. Installing the enclosures.	32
Step 8. Installing the support rails for file module slides	34
Step 9. Installing the file modules	38
Step 10. Connecting the SAS cables to the expansion enclosures	42
Step 11. Attaching the Ethernet cables	47
Step 12. Attaching the Fibre Channel cables.	52
Step 13. Connecting the power cords	54
Step 14. Powering the system on and off	56

Chapter 3. Initializing the system **63**

Step 15. Using InitTool.exe on the USB flash drive	63
Step 16. Initialize the Storwize V7000.	64
Step 17. Initializing the file modules	65

Chapter 4. Configuring the system. . . . **67**

Step 18. Configuring the system using the management GUI	67
Step 19. Change default passwords	68
Step 20. Check the Storwize V7000 Unified system status	69
Step 21. Upgrade the Storwize V7000 Unified software	69
Step 22. Problems with initial configuration	70
Step 23. Enable IBM Tivoli Assist On-Site (AOS)	73
Step 24. Registering for My Notification	73
Step 25. Next steps	74

Appendix. Accessibility features for IBM Storwize V7000 Unified **75**

Notices **77**

Trademarks	79
Electronic emission notices	79
Federal Communications Commission (FCC) statement	79
Industry Canada compliance statement	80
Avis de conformité à la réglementation d'Industrie Canada	80
Australia and New Zealand Class A Statement	80
European Union Electromagnetic Compatibility Directive	80
Germany Electromagnetic compatibility directive	81
Japan VCCI Council Class A statement	82
People's Republic of China Class A Electronic Emission Statement.	82
International Electrotechnical Commission (IEC) statement	82
United Kingdom telecommunications requirements	82
Korean Communications Commission (KCC) Class A Statement	82
Russia Electromagnetic Interference (EMI) Class A Statement	83
Taiwan Class A compliance statement	83
European Contact Information	83
Taiwan Contact Information	83

Figures

1.	This figure shows 12 drives and two end caps (model 2076-112).	3	25.	Install the file module on the slide rails.	39
2.	This figure shows 24 drives and two end caps (model 2076-124).	4	26.	Slide the file module into the rack.	39
3.	Rear view of a model 2076-112 or a model 2076-124 control enclosure.	4	27.	Install the cable management support arm. It can be installed on either side (left or right). The graphic shows the rear of the rack.	40
4.	This figure shows the data ports in the rear of the control enclosure.	5	28.	Install the cable management arm.	40
5.	10 Gbps Ethernet ports on the rear of the Storwize V7000 enclosure.	6	29.	Adjust the location of the cable management arm.	41
6.	Rear view of a model 2076-212 or a model 2076-224 expansion enclosure.	6	30.	Connect and route the cables.	41
7.	SAS ports and LEDs in rear of expansion enclosure.	7	31.	Secure the cable management arm and the file module in the rack for shipping if needed.	42
8.	Front view of file module.	8	32.	Install the front screws.	42
9.	Rear view of file module.	8	33.	Internal cabling connections between the control enclosure (A) and the expansion enclosures (B & C).	44
10.	Recommended rack locations.	10	34.	Attaching an expansion enclosure to the control enclosure.	45
11.	Examples of the IP addresses and network services needed for the system. The expansion enclosures are not shown.	13	35.	Adding a second expansion enclosure.	46
12.	Here are examples of IP addresses and network services needed for the system. The expansion enclosures are not shown.	16	36.	Attaching SAS cables to the enclosures.	47
13.	Securing an enclosure to a rack cabinet.	30	37.	Control enclosure Ethernet network connections.	48
14.	Hole locations in the front of the rack.	31	38.	10 Gbps Ethernet ports on the rear of the Storwize V7000 enclosure.	49
15.	Hole locations in the back of the rack.	32	39.	File module Ethernet direct connections.	50
16.	Removing the enclosure end cap.	33	40.	Diagram showing how to connect the file modules to the control enclosure using Fibre Channel cables. Refer to previous table.	53
17.	Securing an enclosure to a rack cabinet.	34	41.	Unlocking the cable retention bracket.	55
18.	Cable management arm box contents.	35	42.	Sliding the cable retention bracket directly behind the power cord.	56
19.	Friction rail box contents.	36	43.	24 drives and two end caps.	57
20.	Locate a 2U space in the lower section of the rack.	36	44.	12 drives and two end caps.	57
21.	Open the rear slide rail hooks.	37	45.	LEDs on the power supply units of the expansion enclosure.	58
22.	Install the rear end of the slide rails.	37	46.	LEDs on the power supply units of the control enclosure.	59
23.	Install the front end of the slide rails.	38			
24.	Install the front end of the slide rails.	38			

Tables

1. Storwize V7000 Unified library	xviii	11. LDAP CONFIGURATION INFORMATION	24
2. Other IBM publications	xx	12. NIS configuration information	25
3. IBM documentation and related websites	xx	13. Use this table to identify the file module, control enclosure, and expansion unit port locations. Follow the links to identify detailed port locations..	43
4. The following IP address information is required before initializing your system. Fill in all the information needed in the Value column before proceeding with this installation.	14	14. How to connect SAS cables to expansion units.	44
5. This table can be used for recording the information needed for the initial configuration wizard in the management GUI. The table entries serve as a guide only. Enter the Value column with your system information.	17	15. Ethernet connections available with the control enclosure	49
6. Information that the system will provide to IBM Remote Technical Support	18	16. Ethernet connections available with the file modules	50
7. All the information in this table is required.	19	17. LED status front of control enclosure or expansion enclosure. Refers to item [1] in the figures above..	57
8. CIDR subnet mask information	19	18. LED status rear of expansion enclosure.	58
9. Authentication method information. Refer to the notes above	22	19. LED status when control enclosure is powered on.	59
10. Active Directory Configuration Information	22	20. Create two files and enter one line each, adjusted to the values fitting to your environment.	64

Safety and environmental notices

Review the multilingual safety notices for the IBM® system before you install and use the product.

Suitability for telecommunication environment: This product is not intended to connect directly or indirectly by any means whatsoever to interfaces of public telecommunications networks.

To find the translated text for a caution or danger notice:

1. Look for the identification number at the end of each caution notice or each danger notice. In the following examples, the numbers (C001) and (D002) are the identification numbers.

CAUTION:

A caution notice indicates the presence of a hazard that has the potential of causing moderate or minor personal injury. (C001)

DANGER

<p>A danger notice indicates the presence of a hazard that has the potential of causing death or serious personal injury. (D002)</p>

2. Locate *IBM Systems Safety Notices* with the user publications that were provided with the Storwize® V7000 Unified hardware.
3. Find the matching identification number in the *IBM Systems Safety Notices*. Then review the topics concerning the safety notices to ensure that you are in compliance.
4. Optionally, read the multilingual safety instructions on the Storwize V7000 Unified website. Go to www.ibm.com/storage/support/storwize/v7000/unified and click the documentation link.

Safety

Before installing this product, read the Safety Information.

قبل تركيب هذا المنتج، يجب قراءة الملاحظات الأمنية

Antes de instalar este produto, leia as Informações de Segurança.

在安装本产品之前，请仔细阅读 **Safety Information** (安全信息)。

安裝本產品之前，請先閱讀「安全資訊」。

Prije instalacije ovog produkta obavezno pročitajte Sigurnosne Upute.

Před instalací tohoto produktu si přečtěte příručku bezpečnostních instrukcí.

Læs sikkerhedsforskrifterne, før du installerer dette produkt.

Lees voordat u dit product installeert eerst de veiligheidsvoorschriften.

Ennen kuin asennat tämän tuotteen, lue turvaohjeet kohdasta Safety Information.

Avant d'installer ce produit, lisez les consignes de sécurité.

Vor der Installation dieses Produkts die Sicherheitshinweise lesen.

Πριν εγκαταστήσετε το προϊόν αυτό, διαβάστε τις πληροφορίες ασφάλειας (safety information).

לפני שתתקינו מוצר זה, קראו את הוראות הבטיחות.

A termék telepítése előtt olvassa el a Biztonsági előírásokat!

Prima di installare questo prodotto, leggere le Informazioni sulla Sicurezza.

製品の設置の前に、安全情報をお読みください。

본 제품을 설치하기 전에 안전 정보를 읽으십시오.

Пред да се инсталира овој продукт, прочитајте информацијата за безбедност.

Les sikkerhetsinformasjonen (Safety Information) før du installerer dette produktet.

Przed zainstalowaniem tego produktu, należy zapoznać się z książką "Informacje dotyczące bezpieczeństwa" (Safety Information).

Antes de instalar este produto, leia as Informações sobre Segurança.

Перед установкой продукта прочтите инструкции по технике безопасности.

Pred inštaláciou tohto zariadenia si pečítajte Bezpečnostné predpisy.

Pred namestitvijo tega proizvoda preberite Varnostne informacije.

Antes de instalar este producto, lea la información de seguridad.

Läs säkerhetsinformationen innan du installerar den här produkten.

Safety statements

Each caution and danger statement in this document is labeled with a number. This number is used to cross reference an English-language caution or danger statement with translated versions of the caution or danger statement in the *Safety Information* document. For example, if a caution statement is labeled “Statement 1”, translations for that caution statement are in the *Safety Information* document under “Statement 1.”

Important:

Be sure to read all caution and danger statements in this document before you perform the procedures. Read any additional safety information that comes with the system or optional device before you install the device.

Statement 1



DANGER

Electrical current from power, telephone, and communication cables is hazardous.

To avoid a shock hazard:

- Do not connect or disconnect any cables or perform installation, maintenance, or reconfiguration of this product during an electrical storm.
- Connect all power cords to a properly wired and grounded electrical outlet.
- Connect to properly wired outlets any equipment that will be attached to this product.
- When possible, use one hand only to connect or disconnect signal cables.
- Never turn on any equipment when there is evidence of fire, water, or structural damage.
- Disconnect the attached power cords, telecommunications systems, networks, and modems before you open the device covers, unless instructed otherwise in the installation and configuration procedures.
- Connect and disconnect cables as described in the following table when installing, moving, or opening covers on this product or attached devices.

To Connect:

1. Turn everything OFF.
2. First, attach all cables to devices.
3. Attach signal cables to connectors.
4. Attach power cords to outlet.
5. Turn device ON.

To Disconnect:

1. Turn everything OFF.
2. First, remove power cords from outlet.
3. Remove signal cables from connectors.
4. Remove all cables from devices.

Statement 2



CAUTION:

When replacing the lithium battery, use only IBM Part Number 33F8354 or an equivalent type battery recommended by the manufacturer. If your system has a module containing a lithium battery, replace it only with the same module type made by the same manufacturer. The battery contains lithium and can explode if not properly used, handled, or disposed of.

Do not:

- Throw or immerse into water
- Heat to more than 100°C (212°F)
- Repair or disassemble

Dispose of the battery as required by local ordinances or regulations.

Statement 3



CAUTION:

When laser products (such as CD-ROMs, DVD drives, fiber optic devices, or transmitters) are installed, note the following:

- Do not remove the covers. Removing the covers of the laser product could result in exposure to hazardous laser radiation. There are no serviceable parts inside the device.
- Use of controls or adjustments or performance of procedures other than those specified herein might result in hazardous radiation exposure.



DANGER

Some laser products contain an embedded Class 3A or Class 3B laser diode. Note the following.

Laser radiation when open. Do not stare into the beam, do not view directly with optical instruments, and avoid direct exposure to the beam.



Class 1 Laser Product
Laser Klasse 1
Laser Klass 1
Luokan 1 Laserlaite
Appareil À Laser de Classe 1

Statement 4

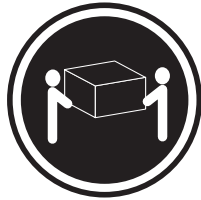

≥ 18 kg (39.7 lb)



≥ 32 kg (70.5 lb)

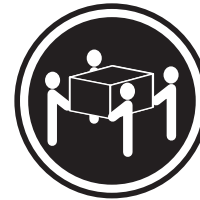

≥ 55 kg (121.2 lb)

CAUTION:
Use safe practices when lifting.

Statement 5



CAUTION:
The power control button on the device and the power switch on the power supply do not turn off the electrical current supplied to the device. The device also might have more than one power cord. To remove all electrical current from the device, ensure that all power cords are disconnected from the power source.

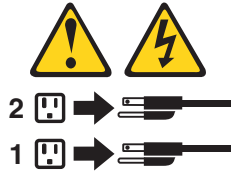

Statement 8



CAUTION:

Never remove the cover on a power supply or any part that has the following label attached.



Hazardous voltage, current, and energy levels are present inside any component that has this label attached. There are no serviceable parts inside these components. If you suspect a problem with one of these parts, contact a service technician.

Statement 26



CAUTION:

Do not place any object on top of rack-mounted devices.



This node is suitable for use on an IT power-distribution system whose maximum phase-to-phase voltage is 240 V under any distribution fault condition.

Important: This product is not suitable for use with visual display workplace devices according to Clause 2 of the German Ordinance for Work with Visual Display Units.

Sound pressure

Attention: Depending on local conditions, the sound pressure can exceed 85 dB(A) during service operations. In such cases, wear appropriate hearing protection.

About this guide

This guide describes how to install the IBM Storwize V7000 Unified system.

The chapters that follow introduce you to the hardware components and requirements needed for installing the Storwize V7000 Unified system.

Who should use this guide

This guide is intended for users installing the Storwize V7000 Unified system.

Before configuring your system make sure you follow the procedures as listed. Be sure to gather IP addresses necessary prior to installation. See “Step 5. Gather information” on page 11.

Accessibility

IBM has a long-standing commitment to people with disabilities. In keeping with that commitment to accessibility, IBM strongly supports the U.S. Federal government's use of accessibility as a criterion in the procurement of Electronic Information Technology (EIT).

IBM strives to provide products with usable access for everyone, regardless of age or ability.

This product uses standard Windows navigation keys.

For more information, see “Accessibility features for *IBM Storwize V7000 Unified*,” on page 75.

Emphasis

Different typefaces are used in this guide to show emphasis.

The following typefaces are used to show emphasis:

Boldface	Text in boldface represents menu items.
Bold monospace	Text in bold monospace represents command names.
<i>Italics</i>	Text in <i>italics</i> is used to emphasize a word. In command syntax, it is used for variables for which you supply actual values, such as a default directory or the name of a system.
Monospace	Text in monospace identifies the data or commands that you type, samples of command output, examples of program code or messages from the system, or names of command flags, parameters, arguments, and name-value pairs.

Storwize V7000 Unified library and related publications

Product manuals, other publications, and websites contain information that relates to Storwize V7000 Unified.

Storwize V7000 Unified Information Center

The IBM Storwize V7000 Unified Information Center contains all of the information that is required to install, configure, and manage the Storwize V7000 Unified. The information center is updated between Storwize V7000 Unified product releases to provide the most current documentation. The information center is available at the following website:

publib.boulder.ibm.com/infocenter/storwize/unified_ic/index.jsp

Storwize V7000 Unified library

Unless otherwise noted, the publications in the Storwize V7000 Unified library are available in Adobe portable document format (PDF) from the following website:

www.ibm.com/storage/support/storwize/v7000/unified

Each of the PDF publications in Table 1 is available in this information center by clicking the number in the “Order number” column:

Table 1. Storwize V7000 Unified library

Title	Description	Order number
<i>Storwize V7000 Unified Quick Installation Guide</i>	This guide provides instructions for unpacking your shipping order and installing your system. The first of three chapters describes verifying your order, becoming familiar with the hardware components, and meeting environmental requirements. The second chapter describes installing the hardware and attaching data cables and power cords. The last chapter describes accessing the management GUI to initially configure your system.	GA32-1056
<i>Storwize V7000 Unified Problem Determination Guide</i>	This guide describes how to service, maintain, and troubleshoot the Storwize V7000 Unified system.	GA32-1057

Table 1. Storwize V7000 Unified library (continued)

Title	Description	Order number
<i>IBM Systems Safety Notices</i>	This guide contains translated caution and danger statements for the node canister documentation. Each caution and danger statement in the Storwize V7000 Unified documentation has a number that you can use to locate the corresponding statement in your language in the <i>IBM Systems Safety Notices</i> document.	G229-9054
<i>Safety Information</i>	This guide contains translated caution and danger statements for the file module documentation. Each caution and danger statement in the Storwize V7000 Unified documentation has a number that you can use to locate the corresponding statement in your language in the <i>Safety Information</i> document.	P/N 59Y7218
<i>Storwize V7000 Unified Read First Flyer</i>	This document introduces the major components of the Storwize V7000 Unified system and describes how to get started with the <i>Storwize V7000 Unified Quick Installation Guide</i> .	GA32-1055
<i>IBM Statement of Limited Warranty (2145 and 2076)</i>	This multilingual document provides information about the IBM warranty for machine types 2145 and 2076.	Part number: 85Y5978
<i>IBM Statement of Limited Warranty (2073)</i>	This multilingual document provides information about the IBM warranty for machine type 2073.	Part number: 00L4547
<i>IBM License Agreement for Machine Code</i>	This multilingual guide contains the License Agreement for Machine Code for the Storwize V7000 Unified product.	SC28-6872 (contains Z125-5468)

Other IBM publications

Table 2 on page xx lists IBM publications that contain information related to the Storwize V7000 Unified.

Table 2. Other IBM publications

Title	Description	Order number
<i>IBM Storage Management Pack for Microsoft System Center Operations Manager User Guide</i>	This guide describes how to install, configure, and use the IBM Storage Management Pack for Microsoft System Center Operations Manager (SCOM).	GC27-3909 publibfp.dhe.ibm.com/epubs/pdf/c2739092.pdf
<i>IBM Storage Management Console for VMware vCenter, version 3.0.0, User Guide</i>	This publication describes how to install, configure, and use the IBM Storage Management Console for VMware vCenter, which enables Storwize V7000 Unified and other IBM storage systems to be integrated in VMware vCenter environments.	GA32-0929 publibfp.dhe.ibm.com/epubs/pdf/a3209295.pdf

IBM documentation and related websites

Table 3 lists websites that provide publications and other information about the Storwize V7000 Unified or related products or technologies.

Table 3. IBM documentation and related websites

Website	Address
Support for Storwize V7000 Unified (2073)	www.ibm.com/storage/support/storwize/v7000/unified
Support for IBM System Storage [®] and IBM TotalStorage products	www.ibm.com/storage/support/
IBM Publications Center	www.ibm.com/e-business/linkweb/publications/servlet/pbi.wss
IBM Redbooks [®] publications	www.redbooks.ibm.com/

Related accessibility information

To view a PDF file, you need Adobe Acrobat Reader, which can be downloaded from the Adobe website:

www.adobe.com/support/downloads/main.html

How to order IBM publications

The IBM Publications Center is a worldwide central repository for IBM product publications and marketing material.

The IBM Publications Center offers customized search functions to help you find the publications that you need. Some publications are available for you to view or download at no charge. You can also order publications. The publications center displays prices in your local currency. You can access the IBM Publications Center through the following website:

www.ibm.com/e-business/linkweb/publications/servlet/pbi.wss

Sending your comments

Your feedback is important in helping to provide the most accurate and highest quality information.

To submit any comments about this book or any other Storwize V7000 Unified documentation:

- Go to the feedback page on the website for the Storwize V7000 Unified Information Center at publib.boulder.ibm.com/infocenter/storwize/unified_ic/index.jsp?topic=/com.ibm.storwize.v7000.unified.doc/feedback_ifs.htm. There you can use the feedback page to enter and submit comments or browse to the topic and use the feedback link in the running footer of that page to identify the topic for which you have a comment.
- Send your comments by email to starpubs@us.ibm.com. Include the following information for this publication or use suitable replacements for the publication title and form number for the publication on which you are commenting:
 - Publication title: IBM Storwize V7000 Unified Quick Installation Guide
 - Publication form number: GA32-1056-07
 - Page, table, or illustration numbers that you are commenting on
 - A detailed description of any information that should be changed

Chapter 1. Before you begin the installation

This topic contains a set of instructions to help you plan your installation.

The *Quick Installation Guide* contains a set of instructions to help you unpack and install your system. The guide is divided into three chapters. The steps in the first chapter involve verifying your order, becoming familiar with the hardware component terminology, and ensuring that you have met the environmental requirements. The steps in the second chapter involve installing the hardware and attaching the data cables and power cords. The final chapter helps you configure the file modules and control enclosures. It ends with enabling the Tivoli Assist On-site support program.

Occasionally you are referred to topics in the Storwize V7000 Unified Information Center. A copy of the Storwize V7000 Unified Information Center is on the CD that is included in your shipping order.

Important information:

1. You must first work through the planning information regarding your physical environment and logical network in the Storwize V7000 Unified Information Center.
2. Ensure that you have available any cables that you are supplying.
3. Pay attention to any flyers that were shipped with your shipping order.
4. Check the IBM support home page <http://www.ibm.com/storage/support/storwize/v7000/unified> for any information relevant to planning, installing and configuring a Storwize V7000 Unified system.
5. The Initial setup e-Learning module is available on the IBM Storwize V7000 Unified Information Center. Refer to Initial set up, located under Learning and tutorials.
6. You should use the management GUI to update to the latest Storwize V7000 Unified software immediately after completing the initial configuration.
7. Event notifications and call homes from the Storwize V7000 storage enclosures are done by e-mail. The IP address of an e-mail server which can access the internet is required. Call home from a file module is done by electronic customer care (ecc) using ssh. This requires a proxy server to access the internet or your firewall must be made to allow each file module service IP address to ssh to the IBM call home IP addresses (*.ibm.com) on the internet.

IBM Storwize V7000 Unified Information Center

The most current information for Storwize V7000 Unified is available in the *IBM Storwize V7000 Unified Information Center* at publib.boulder.ibm.com/infocenter/storwize/unified_ic/index.jsp. If you are unable to access the internet, there is a copy of the information center on the software CD that was shipped with the product, it contains the environmental notices, the publication PDFs, and the information center content. Insert the CD into a Windows based system, it automatically starts.

Step 1. Reviewing your packing slip

Check that your packing slip matches the ship contents.

After you open your box or boxes, locate your packing slip. Ensure that the items that are listed in your packing slip match what is in the box. Ensure that any optional items that you ordered are included in the list. Your shipment might contain additional items depending on the order.

Control enclosure ship contents:

- ___ • Control enclosure (models 2076-112, 2076-124, 2076-312, or 2076-324). The last two digits of the model number identify the number of drive slots, either 12 or 24.
- ___ • Rack-mounting hardware kit, including:
 - ___ – Two rails (right and left assembly)
 - ___ – Two M5 x 15 Hex Phillips screws per rail (two rails)
 - ___ – Two M5 x 15 Hex Phillips screws per chassis

Note: Two parts of the rail kit are attached to each side of the enclosure.

- ___ • Two power cords
- ___ • Drive assemblies or blank carriers (installed in the enclosure).
Verify the number of drives and the size of the drives.

Other items shipped with control enclosure:

- ___ • Read first flyer
- ___ • Quality hotline flyer
- ___ • Environmental notices CD
- ___ • Environmental flyers
- ___ • Safety notices
- ___ • Limited Warranty information
- ___ • Documentation DVD that contains the publication PDFs, and the *IBM Storwize V7000 Unified Information Center* content.
- ___ • License information
- ___ • License Function authorization document
- ___ • IBM Storwize V7000 Unified Quick Installation Guide
- ___ • *Storwize V7000 Unified Problem Determination Guide*
- ___ • One USB flash drive, also known as a flash drive, is located with the publications.

Additional components for control enclosure:

- ___ • Fibre Channel cables, if ordered
- ___ • Small form-factor pluggable (SFP) transceivers that are preinstalled in the enclosure
- ___ • Longwave SFP transceivers, if ordered

Additional components for expansion enclosures:

- ___ • Two SAS cables for each expansion enclosure

Two file modules. Each file module box contains:

- ___ • File module (server)
- ___ • Rack-mounting hardware kit, including:
 - ___ – Two sets of two rails (right and left assembly)
 - ___ – Large cable tie

- __ - Cable ties
- __ - Two sets of four M6 screws per rail (two rails)
- __ - Two sets of two 10-32 screws per chassis
- __ - Cable management support arm
- __ - Cable management arm mounting bracket
- __ - Cable management arm stop bracket
- __ - Cable management arm assembly

Note: The rail kits for the servers differ from the control enclosure.

- __ • Two power cords

Additional components for file modules:

- __ • Read first flyer
- __ • Quality hotline flyer
- __ • Environmental notices CD
- __ • Environmental flyers
- __ • Safety notices
- __ • Limited warranty information
- __ • License information
- __ • License Function authorization document
- __ • Small form-factor pluggable (SFP) transceivers that are preinstalled in the enclosure

Step 2. Identifying the hardware components

The following graphics and descriptions identify the various hardware components and port locations for the control enclosure, expansion enclosure, and file modules.

Control enclosure

Each enclosure has drives that are located on the front. Figure 1 and Figure 2 on page 4 show the front of an enclosure that has space for up to 12 or 24 drives **2**, depending on the model, and a left end cap **1** and a right end cap **3**.

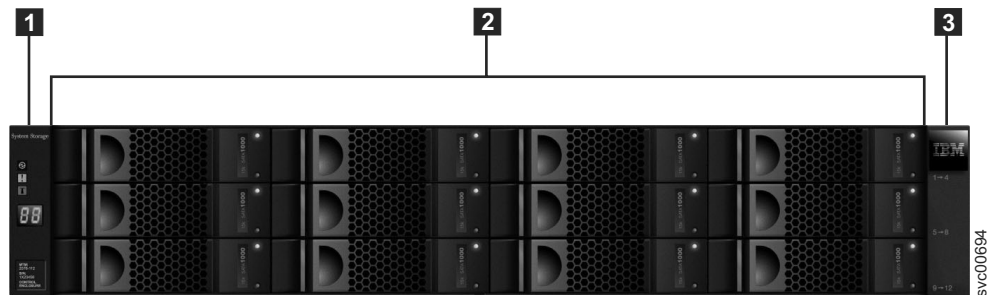

Figure 1. This figure shows 12 drives and two end caps (model 2076-112).



Figure 2. This figure shows 24 drives and two end caps (model 2076-124).

Control enclosure components

Figure 3 shows the rear view of a control enclosure and identifies the location of the power supply units and the canisters.

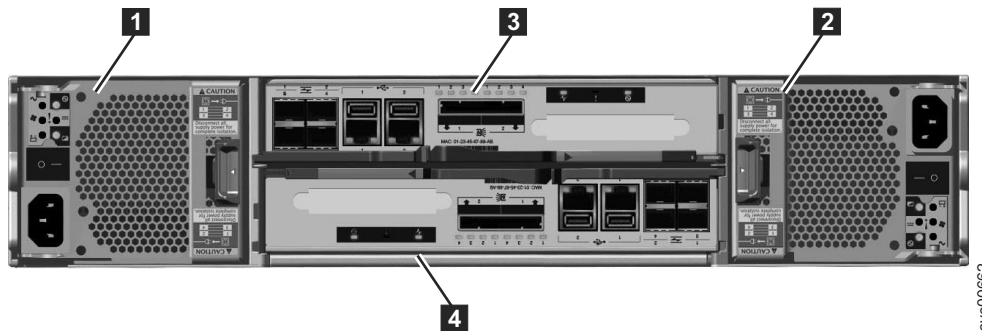

Figure 3. Rear view of a model 2076-112 or a model 2076-124 control enclosure

- Power supply units are located on the left and right of the canisters. Each unit contains a battery. Power supply **1** is located on the left. Power supply **2** is located on the right. Power supply **1** is inserted top side up, and power supply **2** is inverted, or top side down.

Important: The power supply units for the control enclosure and expansion enclosure are not interchangeable.

- Two canisters are housed in the middle of the enclosure. Each canister is known as a node canister. The upper canister, as shown in Figure 3, is labelled **3**, and the lower canister is labelled **4**. Canister **3** is top side up, and canister **4** is inverted, or top side down.

Figure 4 on page 5 shows the rear view of a model 2076-112 or a model 2076-124 control enclosure and identifies the location of the ports.

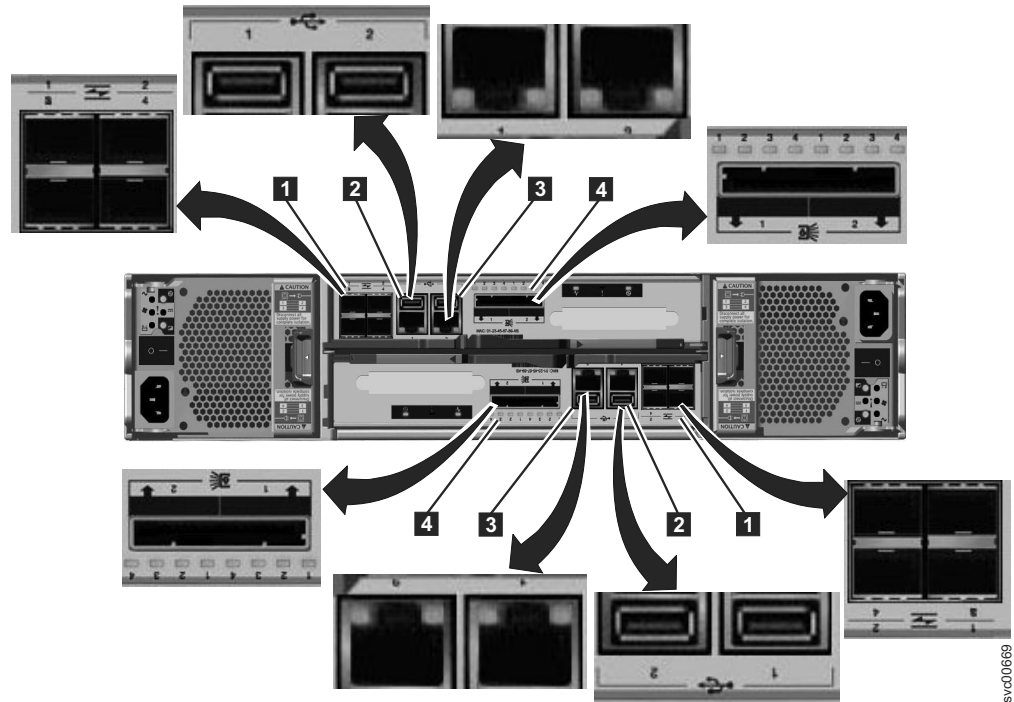

Figure 4. This figure shows the data ports in the rear of the control enclosure.

- **1** Fibre Channel ports. Each canister has four Fibre Channel ports. They are in a block of four in two rows of two connectors. The ports are numbered 1 - 4 from left to right, top to bottom. Two ports connect to the file modules and two are optional.
- **2** USB ports. Each canister has two USB ports. The ports are side by side on the canister and are numbered 1 on the left and 2 on the right. One port is used during installation.
- **3** Ethernet ports. Each canister has two Ethernet ports. The ports are side by side on the canister. They are numbered 1 on the left and 2 on the right on the upper canister. The port locations are inverted for the lower canister. Port 1 must be connected first; the use of port 2 is optional.
- **4** Serial-attached SCSI (SAS) ports. Each canister has two SAS ports. The ports are side by side on the canister. They are numbered 1 on the left and 2 on the right. Port 1 must be connected first if you are adding one expansion enclosure. Port 2 must be connected if you are adding a second expansion enclosure.

Note: The reference to the left and right locations applies to canister 1, which is the upper canister. The port locations are inverted for canister 2, which is the lower canister.

Figure 5 on page 6 shows the rear view of a model 2076-312 or a model 2076-324 control enclosure with the optional 10 Gbps Ethernet ports installed. All other ports remain the same.

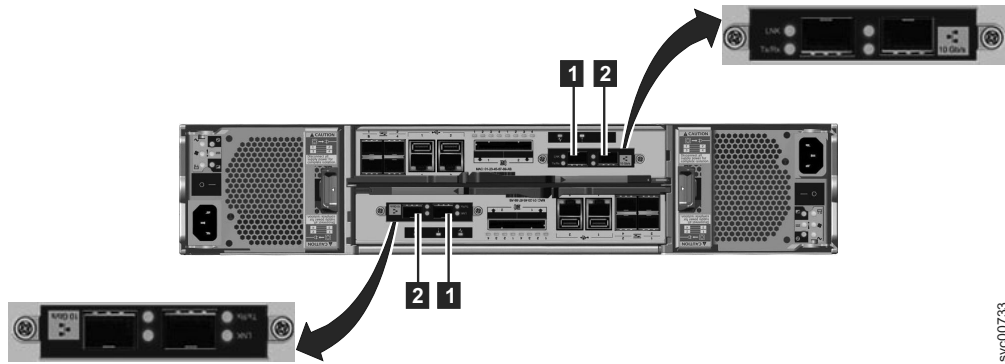

Figure 5. 10 Gbps Ethernet ports on the rear of the Storwize V7000 enclosure

- **1** 10 Gbps Ethernet port 3 which is the left port.
- **2** 10 Gbps Ethernet port 4 which is the right port.

Expansion enclosure components

Figure 6 shows the rear view of an expansion enclosure and identifies the location of the power supply units and the canisters. The ports and their use are described later in this section.

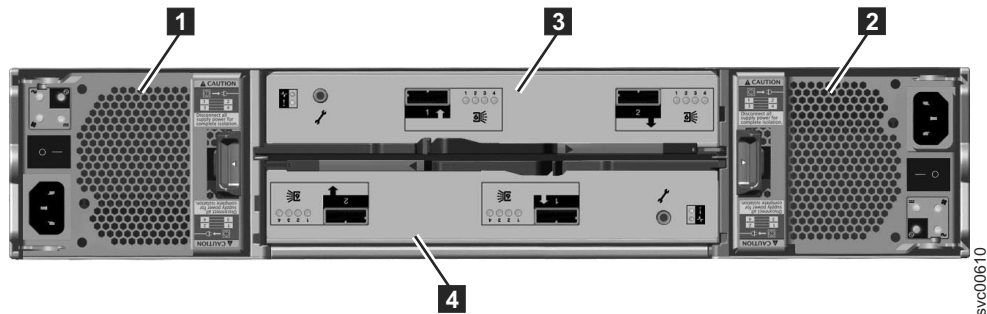

Figure 6. Rear view of a model 2076-212 or a model 2076-224 expansion enclosure

- Power supply units are on the left and right of the canisters. Power supply **1** is located on the left. Power supply **2** is located on the right. Power supply 1 is inserted top side up, and power supply 2 is inverted, or top side down.

Important: The power supply units for the control enclosure and expansion enclosure are not interchangeable.

- Two canisters are housed in the middle of the enclosure. Each canister is known as an expansion canister. The upper canister, as shown in Figure 6, is canister **3**, and the lower canister is canister **4**. Canister 3 is top side up, and canister 4 is inverted, or top side down.

Figure 7 on page 7 shows the rear view of an expansion enclosure and identifies the SAS port locations.

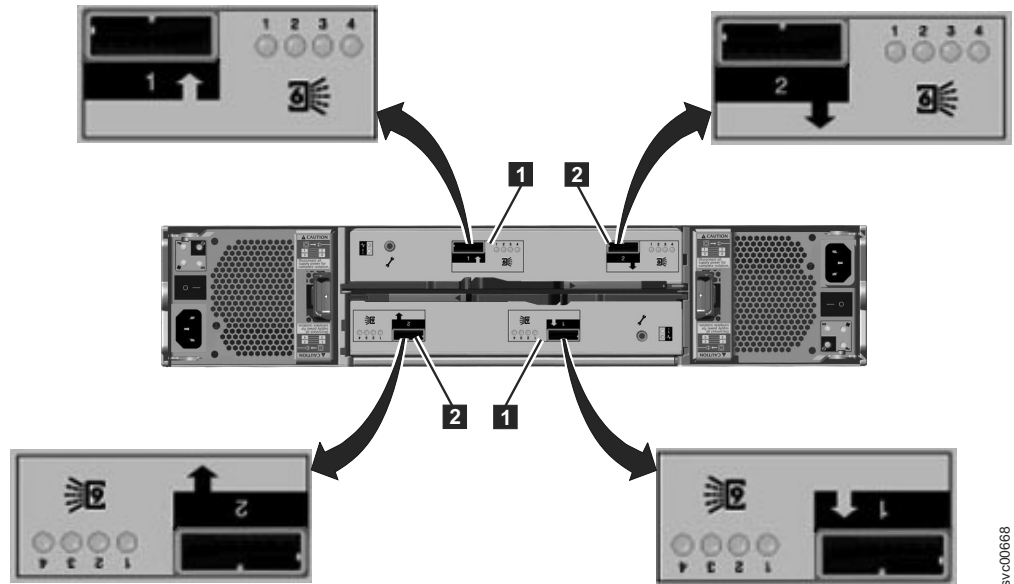

8890068

Figure 7. SAS ports and LEDs in rear of expansion enclosure

Each canister has two SAS ports that are numbered 1 on the left **1** and 2 on the right **2**. Port 1 must be connected if you are adding one expansion enclosure. Port 2 must be connected if you are adding a second expansion enclosure.

Note: The reference to the left and right locations applies to canister 1, which is the upper canister. The port locations are inverted for canister 2, which is the lower canister.

File module

Figure 8 on page 8 identifies the various ports and hardware in the front of the file module:

- **1** VGA port
- **2** USB ports
- **3** CD drive
- **4** Control panel
- **5** Two drives

Each enclosure takes up the full 2U height in the rack. See the *Storwize V7000 Unified Problem Determination Guide* PDF on the CD for the full descriptions of the hardware components.

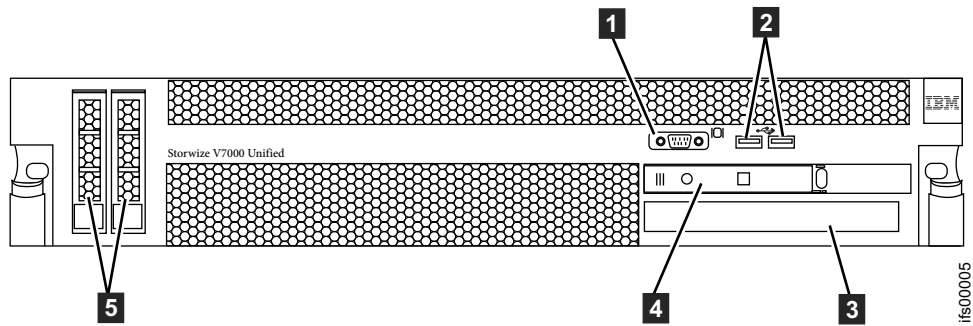

Figure 8. Front view of file module

Figure 9 identifies the various ports and hardware in the rear of the file module:

- **1** Fibre Channel ports, right is port 1, left is port 2
- **2** 10 Gbps Ethernet ports, right is port 0, left is port 1
- **3** Power supply
- **4** USB ports
- **5** Serial port
- **6** Video port
- **7** 1 Gbps Ethernet ports, left is port 1, right is port 2
- **8** 1 Gbps Ethernet ports, left is port 3, right is port 4
- **9** Not used

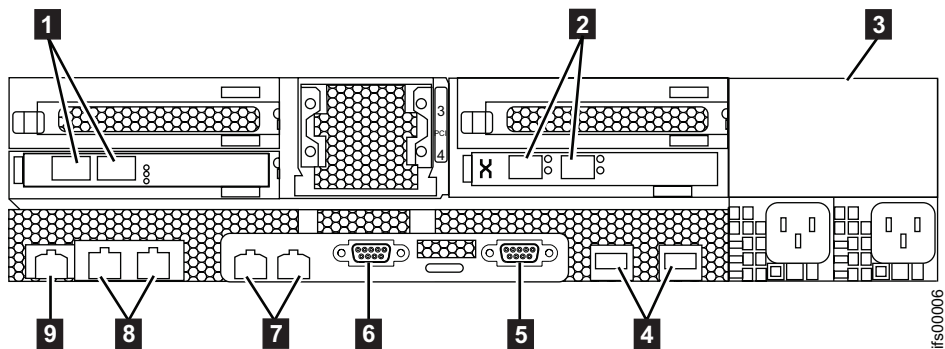

Figure 9. Rear view of file module

Miscellaneous hardware

The USB flash drive (also known as a USB flash drive) is packaged with the publications and contains the initialization tool for performing the initial system configuration.

Step 3. Verifying environmental requirements

Verify that the physical requirements are met.

Certain requirements for the physical site must be met to ensure that your system works reliably. This step includes verifying that adequate space in a suitable rack is available and that requirements for power and environmental conditions are met. This documentation assumes that you have completed the physical planning for the environment of your system.

If you have not done the environmental planning for your system, see the *Storwize V7000 Unified physical installation planning* topic in the Storwize V7000 Unified Information Center.

You must use a supported web browser. Verify that you are using a supported web browser from the following website:

http://publib.boulder.ibm.com/infocenter/storwize/unified_ic/topic/com.ibm.storwize.v7000.unified.130.doc/svc_configuringbrowser_1obg15.html

Step 4. Reviewing enclosure location guidelines

Create a plan that identifies appropriate rack locations for your system.

Control enclosure:

Follow these guidelines to create a plan that identifies an appropriate location in the rack for the enclosure and file modules that you are installing now or will be installing later.

Note: These guidelines assume that you are installing a new enclosure or enclosures. If you are adding enclosures to an existing rack, you must consider the amount of space available and the length of cables to the enclosure.

If you are installing a control enclosure only, follow these guidelines:

Position the enclosure in the rack so that you can easily view it and access it for servicing. This action helps the rack to remain stable and provides a way for two or more people to install and remove the enclosure.

If you are installing a control enclosure plus one or more expansion enclosures, follow these guidelines:

If you have one or more expansion enclosures, position the control enclosure in the middle of the expansion enclosures. Balance the expansion enclosures above and below the control enclosure. Refer to Figure 10 on page 10.

For example, position the control enclosure in the middle of the enclosures for ease of cabling.

- You can have no more than five expansion enclosures attached to SAS port 1 of the control enclosure.
- You can have no more than four expansion enclosures attached to SAS port 2 of the control enclosure.
- Position the enclosures together; avoid adding other equipment between enclosures.
- When you add the first expansion enclosure to a control enclosure, it is preferable to add the enclosure directly below the control enclosure.
- When you add a second expansion enclosure, it is preferable to add the enclosure directly above the control enclosure. For each additional expansion enclosure that you add, alternately add it below or above the control enclosure.
- Position the enclosures in the rack so that you can easily view them and access them for servicing. This action helps the rack to remain stable and provides a way for two or more people to install and remove the enclosures.

If you are installing an expansion enclosure to an existing system, follow these guidelines:

When you add the first expansion enclosure to a control enclosure, it is preferable to add the enclosure directly below the control enclosure. When you add a second expansion enclosure, it is preferable to add the enclosure directly above the control enclosure. For each expansion enclosure that you add, alternately add it below or above the control enclosure. Refer to Figure 10.

If you are adding an expansion enclosure to an existing system, you do not need to power off the system. You can add an expansion enclosure while the system is operational.

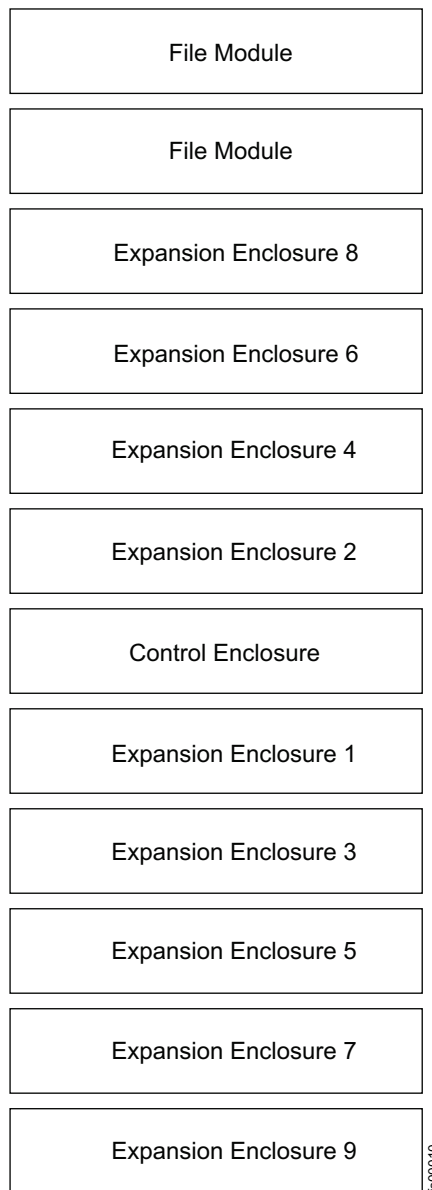

Figure 10. Recommended rack locations

File modules:

- Install both file modules in adjacent slots, near the control enclosure. Other configurations are possible, but all racks must be close together to accommodate cable lengths. A floor plan showing the layout must be developed prior to the start of the installation.

Step 5. Gather information

Gather system information, such as IP addresses, prior to system configuration and initialization.

You need to have some information ready before you begin the initialization of your system, such as the IP addresses. Refer to “Information required before initializing your system” on page 12.

You will need to have some information ready before you start the initial configuration of your system using the management GUI. Refer to “Information required before starting initial configuration of your system” on page 15.

Checking that IP addresses are not already in use

It is very important to check that the IP addresses that you give to the InitTool.exe are not already in use.

About this task

If you provide an IP address that is already in use then the initial setup may appear to be successful and the system could work for some time before random problems start to happen, which could be very hard to troubleshoot. For example, when you use InitTool.exe, you chose an internal IP address range which includes an IP address that happens to be in use on the network already. Then the initial setup may still complete but communication problems may happen later, which are very difficult to troubleshoot. When you eventually realize what you have done then IBM Remote Technical support needs to help you to put your file modules back to out-of-box state so you can chose a different internal IP address range. All other IP addresses can be changed without needing to put the file modules back to out-of-box state.

A reliable way to check that an IP address is not already in use is to logon to a machine that is in the same subnet as the Storwize V7000 Unified system uses for management communications. Then ping the new IP addresses. For example, ping each of the IP addresses that you intend to use in the InitTool.exe.

Follow this process:

1. Log on any machine which is on the same network subnet that the Storwize V7000 Unified system will use for management communications. That is, it has the same network gateway IP address set and the same subnet mask set as the Unified system will use.
2. Ping the network Gateway IP address that the Storwize V7000 Unified system will use. This should indicate 0% packet loss. For example:
ping 123.123.123.1
3. If 2 was successful then ping each of the following IP addresses that you will be providing to InitTool.exe. Each should indicate 100 % packet loss.
 - Storwize V7000 system primary IP address
 - Storwize V7000 system secondary IP address 2 (if you intend to set this)
 - Storwize V7000 node canister 1 service IP address (if you intend to set this)

- Storwize V7000 node canister 2 service IP address (if you intend to set this)
 - Storwize V7000 Unified management IP address
 - File module 1 IP address
 - File module 2 IP address
 - The four IP addresses in the internal IP address range that you intend to chose for management communication between the file modules. For example, one of these sets of addresses
 - a. 10.254.8.1, 10.254.8.2, 10.254.8.3, 10.254.8.10
 - b. 172.31.8.1, 172.31.8.2, 172.31.8.3, 172.31.8.10
 - c. 192.168.8.1, 192.168.8.2, 192.168.8.3, 192.168.8.10
4. If you are utilizing DNS on your network, then the DNS entry for each IP in 3 on page 11 should also be checked utilizing the **nslookup** command to ensure that the DNS names match what you expect. nslookup can be used the same way in Linux, Windows and MacOS):
 nslookup<IP Address> For example, Output from Windows 7:
 nslookup 123.123.123.10
 Server: mydns.mysite.com
 Address: 123.123.123.102
 Name: mysys.mysite.com
 Address: 123.123.123.10

Information required before initializing your system

Use this information to help you prepare to initialize your system.

About this task

The information in Table 4 on page 14 is required before initializing your system. Fill in all the information needed in the **Value** column before starting the initial setup of your system using the Initialization tool (InitTool.exe).

You should also fill in all of the information needed in “Information required before starting initial configuration of your system” on page 15 before you start initializing your system.

WARNING: You must check carefully that the IP addresses that you provide to InitTool.exe are valid and not already in use by some other system on the network apart from the gateway IP address. Refer to “Checking that IP addresses are not already in use” on page 11. If you provide an IP address that is already in use then the initial setup may appear to be successful and the system could work for some time before random problems start to happen which are very hard to troubleshoot.

If you need to change an IP address after initial setup has completed then refer to Connectivity issues for examples of changing IP addresses.

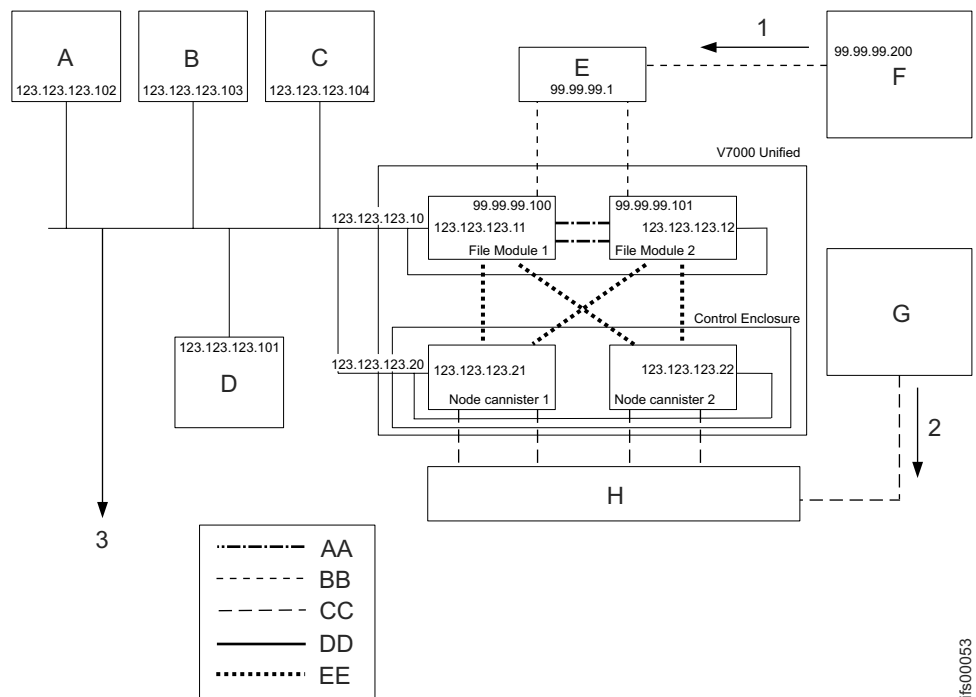

Figure 11. Examples of the IP addresses and network services needed for the system. The expansion enclosures are not shown.

Legend for above graphic:

- **1** File storage path
- **2** Block storage path
- **3** Remote support services via internet
- **A** DNS server
- **B** NTP server
- **C** Email server
- **D** Authentication server
- **E** 10 Gbps Ethernet switch
- **F** Client machine
- **G** Client machine
- **H** Fibre Channel switch
- **AA** 1 Gbps Ethernet direct connection between the file modules
- **BB** 10 Gbps Ethernet network
- **CC** Fibre Channel network
- **DD** 1 Gbps Ethernet
- **EE** Fibre Channel direct connection from file modules to node cannisters

Note: You cannot use VLAN-based subnets to configure the system network. To configure the Storwize V7000 Unified management IP address, file module 1 and 2 IP addresses, subnet mask, and gateway address, you must provide non-VLAN based network information. Also, all IP addresses entered must be on the same subnet. After the system is configured, use the **chnwmgmt** command to change the Storwize V7000 Unified network settings to switch to a VLAN-based subnet. This

recreates the network with a VLAN-based subnet. You must also use the **chsystem -consoleip** CLI command to show the Storwize V7000 the new management IP address.

Note: The example addresses in this table match the ones given on Figure 11 on page 13.

Table 4. The following IP address information is required before initializing your system. Fill in all the information needed in the Value column before proceeding with this installation.

Field	Value	Notes
Storwize V7000 primary IP address		Primary management IP address for the Storwize V7000 system (such as 123.123.123.20)
Storwize V7000 secondary IP address		Optional secondary management IP address of the Storwize V7000 system (such as 123.123.123.19) This is not set by the USB initialize or through the initial configuration wizard in the management GUI. Refer to “Step 25. Next steps” on page 74 to help you configure this option later.
Storwize V7000 node canister 1 service IP address		Optional service IP address of canister 1 in the control enclosure (such as 123.123.123.21) This is not set by the USB initialize or through the initial configuration wizard in management GUI. Refer to “Step 25. Next steps” on page 74 to help you configure this option later.
Storwize V7000 node canister 2 service IP address		Service IP address of canister 2 in the control enclosure (such as 123.123.123.22) This is not set by the USB initialize or through the initial configuration wizard in management GUI. Refer to “Step 25. Next steps” on page 74 to help you configure this option later.
Network subnet mask		Subnet mask for the network subnet in which the management IP addresses for the system will all reside. (such as 255.255.255.0)
Network gateway IP address		The network gateway IP address for this subnet (such as 123.123.123.1)

Table 4. The following IP address information is required before initializing your system. Fill in all the information needed in the Value column before proceeding with this installation. (continued)

Field	Value	Notes
Internal IP address range		<p>The internal IP addresses are for internal communication between the file modules. Select one of the IP address ranges listed below. The available IP address ranges are:</p> <ol style="list-style-type: none"> 1. 10.254.8.1, 10.254.8.2, 10.254.8.3, 10.254.8.10 2. 172.31.8.1, 172.31.8.2, 172.31.8.3, 172.31.8.10 3. 192.168.8.1, 192.168.8.2, 192.168.8.3, 192.168.8.10 <p>Important: You must check carefully that each of the IP addresses in the range that you chose are not already in use somewhere else in your network. Refer to “Checking that IP addresses are not already in use” on page 11.</p>
Storwize V7000 Unified management IP address		<p>Management IP address for the Storwize V7000 Unified system. This gives access to the management GUI and CLI running on which ever file module is currently the active management node (such as 123.123.123.10)</p>
File module 1 IP address		<p>The service access IP address assigned to file module 1 (such as 123.123.123.11)</p>
File module 2 IP address		<p>The service access IP address assigned to file module 2 (such as 123.123.123.12)</p>

Note: The Storwize V7000 service IP addresses are not set by the USB Initialize or by the initial configuration done through the management GUI. Refer to “Step 25. Next steps” on page 74 for how to set them.

Additional information must be ready before you start the initial configuration of your system using the “Step 18. Configuring the system using the management GUI” on page 67. Refer to “Information required before starting initial configuration of your system.”

Information required before starting initial configuration of your system

Identify the information needed to configure your system using the management GUI.

About this task

You must enter specific information into the management GUI. These tables help you record the key values needed before the initial set up and initial configuration.

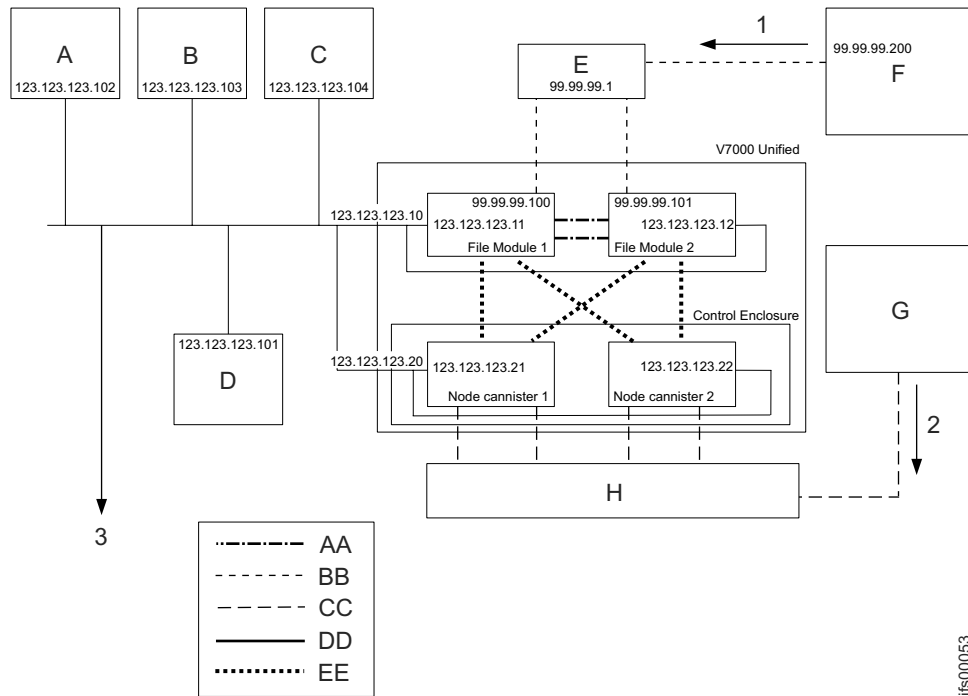

Figure 12. Here are examples of IP addresses and network services needed for the system. The expansion enclosures are not shown.

Legend for above graphic:

- **1** File storage path
- **2** Block storage path
- **3** Remote support services via internet
- **A** DNS server
- **B** NTP server
- **C** Email server
- **D** Authentication server
- **E** 10 Gbps Ethernet switch
- **F** Client machine
- **G** Client machine (fibre channel attached host)
- **H** Fibre Channel switch
- **AA** 1 Gbps Ethernet direct connection between the file modules
- **BB** 10 Gbps Ethernet network
- **CC** Fibre Channel network
- **DD** 1 Gbps Ethernet
- **EE** Fibre Channel direct connection from file module to node canisters

Required information:

Fill out all the information in the following tables in order to navigate through the initial configuration wizard in the management GUI. Your chances of completing the initial configuration successfully are greatly increased if you have carefully planned and completed these tables before you start the initial setup and initial configuration of the system.

Table 5. This table can be used for recording the information needed for the initial configuration wizard in the management GUI. The table entries serve as a guide only. Enter the Value column with your system information.

Field	Value	Notes
System name		The name of the Storwize V7000 Unified system. It is best if this is also the IP name for the management IP address (For example : myfilesystem1)
NetBIOS name		Name used for NetBIOS access to the system. Note: To change the NetBIOS name after the initial configuration, use the cfgcluster CLI command.
Time zone		Refer to Time Zone List in the IBM Storwize V7000 Unified Information Center. Example: If the machine is being installed in Tucson, Arizona, USA, the best match for the time zone is America/Phoenix. You will match this to a drop down menu located in the management GUI.
Network Time Protocol (NTP) Server		Site NTP server address (for example, 123.123.123.103)
Alternate NTP server		Alternate NTP server if applicable
VLAN ID		Optional. This list shows one or more Virtual LAN Identifiers. A VLAN ID must be in the range from 2 to 4095. If you do not use VLANs then leave this field blank.
Domain name		This name is the public network domain name. Example: company.com The system name and domain name are typically used in combination. Example: myfilesytem1.company.com
DNS servers		Numerical address of user Domain Name Server (for example, 123.123.123.102) can be multiple server addresses
DNS search domain		Additional domain names to be used with primary domain name (for example, a.company.com or us.company.com)
Authentication method for network access to file systems		Refer to Table 9 on page 22, Table 10 on page 22, Table 11 on page 24, Table 12 on page 25 to set up your authentication method. When done, return here to continue.
Public subnet or subnets		Where subnet is the numeric IP address of the public network (data path). It is used for all of the Ethernet data path connections. Note: The Subnet is entered as the subnet address followed by the CIDR equivalent of the subnet mask (for example 99.99.99.0/24). You may have more than one public network to access the file systems and file sets shared by this system.
Public subnet mask or subnet masks		This is the subnet mask or subnet masks associated with the public subnet or subnets (for example, 255.255.255.0).

Table 5. This table can be used for recording the information needed for the initial configuration wizard in the management GUI. The table entries serve as a guide only. Enter the Value column with your system information. (continued)

Field	Value	Notes
CIDR equivalent of the subnet mask		This is the CIDR (/XX) equivalent of the subnet mask that was specified previously. Look up the subnet mask (specified previously) then refer to the Table 8 on page 19 and find the CIDR equivalent and record it on this line. It must be between /0 and /32 (for example, /24).
Default gateway IP address		This is the numeric gateway IP address. It is used for all network access to the file systems. For example, 99.99.99.1
Public IP addresses		The public IP addresses are the data path connections to your network. They are used for all of the Ethernet data path connections the file modules. At least 2 addresses are recommended (1 per node). The data path connections use Ethernet bonding, so a single IP address (along with a subnet mask and gateway) is used for all available Ethernet ports on a single file module. The system automatically load balances between the physical ports on a single file module. (For example, 99.99.99.100, 99.99.99.101,99.99.99.102,99.99.103)
Additional public gateway IP addresses		Additional gateways IP addresses for access to the file systems across each of the public networks.
Email server IP address		The IP address of your email server for outgoing mail (for example, 123.123.123.104)

Table 6. Information that the system will provide to IBM Remote Technical Support

Field	Value	Note
Company Name		The name of your company
Address		This is the address where the machines are located. Example: Bldg. 123, Room 456, 789 N Data Center Rd, City, State
Your Contact Phone Number		This is the primary phone number that IBM Remote Technical Support will call, if the system calls home to report a problem.
Your Off Shift Contact Phone Number		This is the alternate phone number that IBM Remote Technical Support will call, if the system calls home to report a problem.
IP address of proxy server (for call home)	_____	Optional. If a proxy server is needed to access the internet for Call Home from the file modules, this is the IP address of that server. If no proxy server is used, leave this field blank.
Port Of Proxy Server (For Call Home)		Optional. If a proxy server is needed, this is the port corresponding to the IP address listed previously. If no proxy server is used, leave this field blank.

Table 6. Information that the system will provide to IBM Remote Technical Support (continued)

Field	Value	Note
Userid For Proxy Server (For Call Home)		Optional. If a proxy server is needed, and the proxy server requires a user ID and password, record the user ID here. If no proxy server is used, or no user ID and password are used, leave this field blank.
Password For Proxy Server (For Call Home)		Optional. If a proxy server is needed, and the proxy server requires a user ID and password, record the password here. If no proxy server is used, or no user ID and password are used, leave this field blank.

If a proxy server is not used, your network must provide access to the following addresses and ports to facilitate call home from each of the file module service IP addresses. Note that call home from one of the storage enclosures is done using email.

Table 7. All the information in this table is required.

Host Name	IP Address	Port	Description
eccgw01.boulder.ibm.com	207.25.252.197	443	ECC transaction gateway
eccgw02.rochester.ibm.com	129.42.160.51	443	ECC transaction gateway
ftp.ecurep.ibm.com	192.109.81.7	20, 21	File upload for status reporting and problem reporting through FTP
www6.software.ibm.com	170.225.15.41	443	File upload for status reporting and problem reporting. Proxy to testcase.boulder.ibm.com
www-945.ibm.com	129.42.26.224	443	Problem reporting server v4
www-945.ibm.com	129.42.34.224	443	Problem reporting server v4
www-945.ibm.com	129.42.42.224	443	Problem reporting server v4
www.ibm.com	129.42.56.216	80, 443	Service provider file (CCF) download
www.ibm.com	129.42.58.216	80, 443	Service provider file (CCF) download
www.ibm.com	129.42.60.216	80, 443	Service provider file (CCF) download
www-03.ibm.com	204.146.30.17	80, 443	Service provider file (CCF) download

Table 8. CIDR subnet mask information

Subnet Mask	CIDR Equivalent	Note
255.255.255.255	/32	Host (single address)
255.255.255.254	/31	Unusable
255.255.255.252	/30	2 usable
255.255.255.248	/29	6 usable
255.255.255.240	/28	14 usable
255.255.255.224	/27	30 usable

Table 8. CIDR subnet mask information (continued)

Subnet Mask	CIDR Equivalent	Note
255.255.255.192	/26	62 usable
255.255.255.128	/25	126 usable
255.255.255.0	/24	Class C 254 usable
255.255.254.0	/23	2 Class Cs
255.255.252.0	/22	4 Class Cs
255.255.248.0	/21	8 Class Cs
255.255.240.0	/20	16 Class Cs
255.255.224.0	/19	32 Class Cs
255.255.192.0	/18	64 Class Cs
255.255.128.0	/17	128 Class Cs
255.255.0.0	/16	Class B
255.254.0.0	/15	2 Class Bs
255.252.0.0	/14	4 Class Bs
255.248.0.0	/13	8 Class Bs
255.240.0.0	/12	16 Class Bs
255.224.0.0	/11	32 Class Bs
255.192.0.0	/10	64 Class Bs
255.128.0.0	/9	128 Class Bs
255.0.0.0	/8	Class A
254.0.0.0	/7	2 Class As
254.0.0.0	/6	4 Class As
252.0.0.0	/5	2 Class As
248.0.0.0	/4	8 Class As
224.0.0.0	/3	16 Class As
192.0.0.0	/2	32 Class As
128.0.0.0	/1	64 Class As
0.0.0.0	/0	IP space

Authentication Method Decision Tree:

The Storwize V7000 Unified systems require one, and only one, authentication system to allow network users to access file systems or file sets exported (shared) by the Storwize V7000 Unified system. The authentication system may also be used to provide User ID mapping. Several authentication methods are supported. They are:

- Microsoft Active Directory - with or without SUA / SFU
- Lightweight Directory Access Protocol (LDAP)
- Network Information Service (NIS)

A local LDAP server can also be used which runs on the file modules, but this is limited. For example it does not support asynchronous filesystem replication to another Storwize V7000 Unified system. Refer to Managing authentication and ID mapping, located in the Information Center.

Use the flow chart below to assist in deciding which authentication method is right for you. The factors that influence the decision are the types of client hosts, the existing authentication infrastructure (if any), and if asynchronous file system replication is to be utilized.

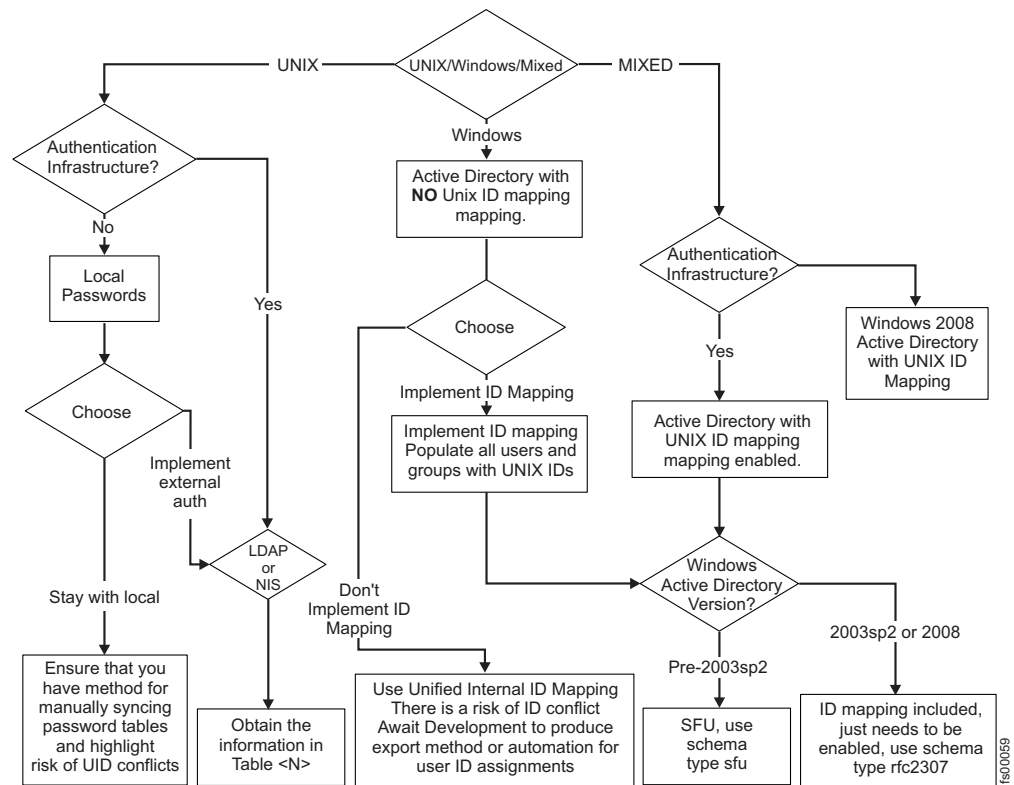

Internally the Storwize V7000 Unified use IBM's General Parallel File System (GPFS). GPFS is a Unix file system, and uses Unix style User IDs (UID) and Group Ids (GID) to manage file permissions. In order for Windows (CIFS) users to access files, there has to be some sort of User ID Mapping. For example, some way to map the Windows user and group objects to Unix UIDs and GIDs. The Storwize V7000 Unified support user ID mapping either internally or externally. While external user ID mapping is preferred, internal mapping can be done using a table local to the Storwize V7000 Unified to map Windows user and group objects to arbitrary Unix UIDs and GIDs. That table is not accessible externally, even to another Storwize V7000 Unified system for asynchronous file system replication. Thus asynchronous replication requires external user ID mapping, specifically Windows Active Directory with the Subsystem for Unix (SUA) enabled and populated. Mixed client access, i.e. having both Unix and Windows clients access the same files (via NFS and CIFS) also requires external user mapping using either AD with SUA/SFU or LDAP with Samba extensions.

Table 9. Authentication method information. Refer to the notes above

Field	Value	Note
Authentication Method	<input type="checkbox"/> Microsoft Active Directory (AD) <input type="checkbox"/> Lightweight Directory Access Protocol (LDAP) <input type="checkbox"/> Samba Primary Domain Controller (PDC) - NT4 <input type="checkbox"/> None (requires configuring Network Information Service (NIS) for NFS NetGroup support)	Check one of the options. If you check None , do not select either of the following NIS options.
Options	<input type="checkbox"/> Kerberos, compatible with authentication method of LDAP only <input type="checkbox"/> Services For UNIX (SFU) - compatible with authentication method of AD only <input type="checkbox"/> Network Information Service (NIS) - NFS NetGroup support without User ID Mapping - compatible with authentication method of AD or PDC only. <input type="checkbox"/> Network Information Service (NIS) - NFS NetGroup support authentication method with User ID Mapping - compatible with authentication method of AD or PDC only.	One or more of these optional capabilities may be used to extend the capabilities of the authentication method selected previously. If none of these options are needed then leave this row blank.

If you checked Microsoft Active Directory in the **Authentication Method** field of Table 9, then you must complete this table.

Table 10. Active Directory Configuration Information

Field	Value	Note
Active Directory Server Ip Address	_____ _____	This is the numeric IP address of the remote Active Directory server (domain controller) on your network.
Active Directory Userid		This is the user ID that must be provided when communicating with the remote Active Directory server. The following user ID and the password are used to authenticate to the Active Directory server.
Active Directory Password		This is the password that must be provided when communicating with the remote Active Directory server.

Table 10. Active Directory Configuration Information (continued)

Field	Value	Note
SFU DOMAIN NAME		<p>If you checked Services For Unix (SFU) in the Options field of Table 9 on page 22, then you must complete this field. If you did not check SFU, leave this field blank.</p> <p>This field is used to specify the Trusted Domain Name for the Active Directory server.</p>
SFU RANGE	Upper range: _____ Lower range: _____	<p>If you checked Services For Unix (Sfu) in the Options field of Table 9 on page 22, then you must complete this field. If you did not check SFU, leave this field blank.</p> <p>This field is used to specify the Lower and Upper bounds of the User Identifier (UID) and Group Identifier (GID) ranges for the storage system. Use the format Lower-Upper (for example, 25-37).</p> <p>The SFU Range must contain the UNIX UID/GID numbers corresponding to users/groups who need to access the system with SFU.</p> <p>The primary group assigned to the SFU users must be an existing Active Directory group with a valid UNIX GID assigned to it. The SFU users must have the same UNIX Attribute primary group and Windows primary group.</p> <p>The UNIX UID/GID that are assigned to such users/groups must be in the ID range provided with -cp parameter of the cfgsfu command. The range for UID/GID must not intersect with 10000000-11000000, this range is used by Scale Out Network Attached Storage internally for other UID/GID mapping</p>
SFU SCHEMA MODE	<input type="checkbox"/> SFU <input type="checkbox"/> rfc2307	<p>If you checked Services For Unix (Sfu) in the Options field of Table 9 on page 22, then you must complete this field. If you did not check SFU, leave this field blank.</p> <p>This field is used to specify the schema Mode. The schema Mode can be either sfu or rfc2307 depending on the operating system of the Active Directory domain server. If the operating system of the domain server is Microsoft Windows 2008 or Windows 2003 with SP2R2 packages use the schemaMode of rfc2307 for Windows 2000 and Windows 2003 with SP1, use sfu.</p>

If you checked **LDAP** in the **Authentication Method** field of Table 9 on page 22, then you must complete this table.

Table 11. LDAP CONFIGURATION INFORMATION

Field	Value	Note
LDAP SERVER IP ADDRESS	____.____.____.____ ____.____.____.____	This is the numeric IP address of the remote LDAP server on your network.
SECURITY METHOD	<input type="checkbox"/> Off <input type="checkbox"/> SSL (Secure Sockets Layer) <input type="checkbox"/> TLS (Transport Layer Security)	<p>The communications link between the Storwize V7000 Unified system and your LDAP server may be open (unencrypted), or may be secured (encrypted). If secured, one of two methods is used: SSL or TLS.</p> <p>Note: When SSL or TLS is used, a security certificate file must be copied from your LDAP server to the Storwize V7000 Unified Management Node.</p>
Certificate Path		If the SSL method is Off, leave this field blank. If the SSL method is SSL or TLS, record the path on the Storwize V7000 Unified Management Node where you copy the Certificate file. As an example, if the Certificate File is cacert.pem and you store it in a directory called /certificates, then record /certificates/cacert.pem .
User Suffix		Specifies the LDAP user suffix to be used.
Group Suffix		Specifies the LDAP group suffix to be used.
Bind Distinguished Name		This is the bind distinguished name from the /etc/openldap/slapd.conf file on your LDAP server. In the example following note 1 below, the bind distinguished name is cn=Manager,dc=v7kuldap,dc=com
Bind Password		This is the bind password from the /etc/openldap/slapd.conf file on your LDAP server. In the example following note 1 below, the bind password is secret .
Kerberos Server Name		If you checked Kerberos in the Options field of Table 9 on page 22, then you must complete this field. If you did not check Kerberos, leave this field blank. This field is the name of the Kerberos server used with your LDAP environment.
Kerberos Realm		If you checked Kerberos in the Options field of Table 9 on page 22, then you must complete this field. If you did not check Kerberos, leave this field blank. This field is the Realm for the Kerberos server used with your LDAP environment.
Kerberos Keytab File		If you checked Kerberos in the Options field of Table 9 on page 22, then you must complete this field. If you did not check Kerberos, leave this field blank. This field is the file name for the Kerberos KeyTab file.

Table 12. NIS configuration information

Field	Value	Note
NIS MODE	<p><input type="checkbox"/> Basic - NIS is used (to provide NFS NetGroup support) in an environment without Active Directory (AD), LDAP, or Samba Primary Domain Controller (PDC).</p> <p><input type="checkbox"/> Extended - NIS is used (to provide NFS NetGroup support or to map UNIX IDs to Windows IDs) for an environment where Active Directory (AD) or Samba Primary Domain Controller (PDC) is used for Authentication.</p>	<p>NIS is typically used for one of the following purposes:</p> <ul style="list-style-type: none"> • NIS can be used to provide NFS Netgroup support in an environment without AD, LDAP, or PDC. • NIS can be used to provide NFS Netgroup support in an environment with AD, or PDC. • NIS can be used to provide NFS NetGroup support and map UNIX user IDs (which are numeric) to Windows user IDs (which are text strings), allowing UNIX servers to access Network Attached Storage devices that use Microsoft Active Directory or PDC to authenticate users. <p>If you checked None in the Authentication Method field of Table 9 on page 22, then select Basic.</p> <p>If you checked either of the NIS items in the Options field of Table 9 on page 22, then select Extended.</p>
Domain Map		<p>If the NIS Mode is Basic, leave this field blank.</p> <p>If the NIS mode is Extended, this field is optional.</p> <p>This field can be used to specify the mapping between AD domains and different NIS domains.</p> <p>When specifying a domain map, use a colon between the AD domain and the NIS domain or domains. Example: ad_domain:nis_domain1</p> <p>If more than one NIS domain is specified, use a comma-separated list. Example: ad_domain:nis_domain1,nis_domain2</p> <p>To specify more than one AD domain, use a semicolon. Example: ad_domain1:nis_domain1,nis_domain2; ad_domain2:nis_domain3,nis_domain4</p>

Table 12. NIS configuration information (continued)

Field	Value	Note
Server Map		<p>This field must be used to specify the mapping between NIS servers and NIS domains.</p> <p>When specifying a server map, use a colon between the NIS server and the NIS domain or domains. Example: nis_server:nis_domain1</p> <p>If more than one NIS domain is specified, use a comma-separated list. Example: nis_server:nis_domain1,nis_domain2</p> <p>To specify more than one NIS server, use a semicolon. Example: nis_server1:nis_domain1,nis_domain2; nis_server2:nis_domain3,nis_domain4</p>
User Map		<p>If the NIS Mode is Basic, leave this field blank.</p> <p>This optional field can be used to specify the handling for a user who is not known to the NIS server. Only one rule can be specified for each AD or PDC domain.</p> <p>The handling is specified using one of the following keywords:</p> <ul style="list-style-type: none"> • DENY_ACCESS - denies any user from the specified domain access if they do not have a mapping entry in the NIS. Example: ad_domain1:DENY_ACCESS • AUTO - a new ID for the user is generated from the specific domain which does not have an entry in the NIS. This ID is generated from a pre-specified ID range and is auto-incremented. The administrator must make sure that existing NIS IDs do not fall in this provided ID range. This mapping is kept in Scale Out Network Attached Storage and NIS is not aware of this ID mapping. The ID range can be specified using the ID Map User Range and ID Map Group Range options. Example: ad_domain1:AUTO • DEFAULT - any user from the specified domain who does not have a mapping entry in the NIS server is mapped to a specified user (typically a guest user). Example: ad_domain1:DEFAULT:ad_domain\guest <p>To specify rules for multiple AD or PDC domains, separate the rules with a semicolon. Example: ad_domain1:DENY_ACCESS; ad_domain2:AUTO; ad_domain3:DEFAULT:ad_domain3\guest</p>
NIS DOMAIN		<p>This field must be used to specify the NIS Domain that is stored in the registry.</p>

Table 12. NIS configuration information (continued)

Field	Value	Note
Use Id Map	[] Use ID Map - NIS is used to map UNIX IDs to Windows IDs for an environment where Active Directory (AD) or Samba Primary Domain Controller (PDC) is used for Authentication.	<p>If the NIS Mode is Basic, leave this field blank.</p> <p>If you checked NIS - NFS NetGroup support without User ID Mapping in the Options field of Table 9 on page 22, leave this field blank.</p> <p>If you checked NIS - NFS NetGroup support with User ID Mapping in the Options field of Table 9 on page 22, then check the Use ID Map field.</p>
ID MAP USER RANGE		<p>If the Use ID Map field is blank, leave this field blank.</p> <p>If the Use ID Map field is checked AND at least one User Map rule is AUTO then you must specify a User Range and/or a Group Range. Example: 10000-20000. Note: The User Range values must be a minimum of 1024.</p>
ID MAP GROUP RANGE		<p>If the Use ID Map field is blank, leave this field blank.</p> <p>If the Use ID Map field is checked AND at least one User Map rule is AUTO then you must specify a User Range and/or a Group Range. Example: 30000-40000. Note: The Group Range values must be a minimum of 1024.</p>

Chapter 2. Performing the hardware installation

Install the hardware components and connect the data cables and power cords.

You have completed the initial steps of verifying the shipping contents and becoming familiar with the hardware components. You have verified that the power and environmental requirements are met and have planned the location of the enclosures and file modules. You are now ready to begin installing the hardware components and connecting the data cables and power cords.

Step 6. Installing the support rails for the enclosures

Install the enclosure's support rails in the rack.

About this task

Review the documentation that comes with the rack cabinet for safety and cabling information. Before you install the control enclosure in a rack cabinet, review the following guidelines

- Two or more people are required to install devices 2U or larger in a rack cabinet.
- Make sure that the room air temperature is below 35°C (95°F).
- Do not block any air vents; usually 15 cm (6 inch) of space provides proper airflow.
- Do not leave open spaces above or below an installed control enclosure in the rack cabinet. To help prevent damage to control enclosure components, always install a blank filler panel to cover the open space and to help ensure proper air circulation. Install the control enclosure only in a rack cabinet with perforated doors.
- Plan the device installation starting from the bottom of the rack cabinet.
- Install the heaviest device in the bottom of the rack cabinet.
- Do not extend more than one device out of the rack cabinet at the same time.
- Remove the rack doors and side panels to provide easier access during installation.
- Connect the control enclosure to a properly grounded outlet.
- Do not overload the power outlet when you install multiple devices in the rack cabinet.
- Install the control enclosure in a rack that meets the following requirements:
 - Minimum depth of 70 mm (2.76 inch) between the front mounting flange and inside of the front door.
 - Minimum depth of 157 mm (6.18 inch) between the rear mounting flange and inside of the rear door.



Figure 13. Securing an enclosure to a rack cabinet

- Minimum depth of 718 mm (28.27 inch) and maximum depth of 762 mm (30 inch) between the front and rear mounting flanges to support the use of the cable management arm.

To install the support rails, perform the following steps:

1. Locate the rack mounting rails and screws.

The rail assembly is made up of two sets of rails. One set of rails is already installed, or preinstalled, on the sides of the enclosures. The other set of rails must be installed in the rack cabinet. The rails on the sides of the enclosures slide into the rails that are installed in the rack cabinet.

2. Working at the front of the rack cabinet, identify the two standard rack units of space in the rack into which you want to install the support rails.

Figure 14 on page 31 shows two rack units with the front mounting holes identified.

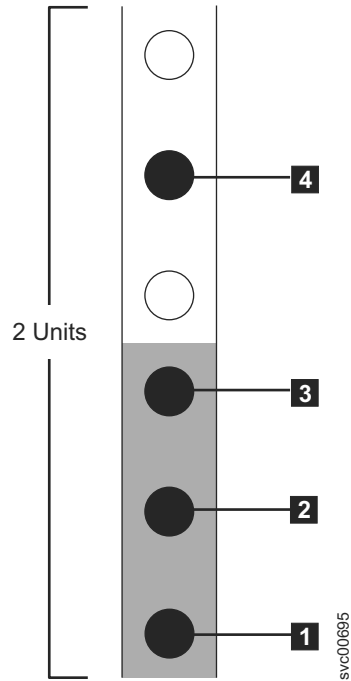

Figure 14. Hole locations in the front of the rack

- **1** Bottom rail location pin hole
 - **2** Enclosure mounting screw hole. Do not insert the screw until the enclosure is installed.
 - **3** Rack mounting screw hole
 - **4** Top rail location pin hole
3. Align the bottom of the rail with the bottom of the two rack units. Insert the rail location pins **1** and **4** through the holes in the rack cabinet.
 4. Insert a clamping screw into the rack mounting hole **3** between the rail location pins.
 5. Tighten the screw to secure the rail to the rack.
 6. Working from the rear of the rack cabinet, extend the rail that you secured to the front to align the bottom of the rail with the bottom of the two rack units.

Note: Ensure that the rail is level between the front and the back.

Figure 15 on page 32 shows two rack units with the back mounting holes identified.

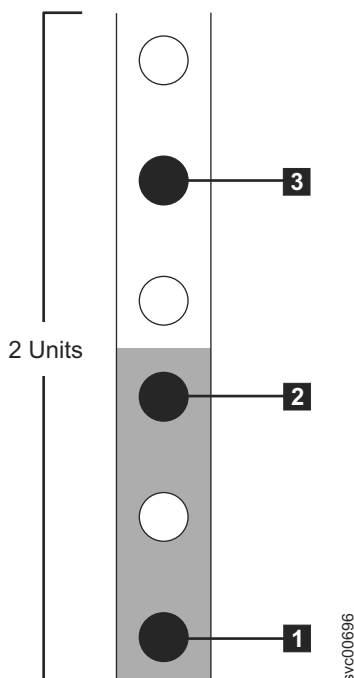

Figure 15. Hole locations in the back of the rack

- **1** Bottom rail location pin hole
 - **2** Rack mounting screw hole
 - **3** Top rail location pin hole
7. Insert the rail location pins through the holes **1** and **3** in the rack cabinet.
 8. Insert a clamping screw into the rack mounting hole **2** between the rail location pins.
 9. Tighten the screw to secure the rail to the rack from the back side.
 10. Repeat the steps to secure the opposite rail to the rack cabinet.
 11. Repeat the procedure for each additional enclosure.

Step 7. Installing the enclosures

Install the enclosures making sure you follow the safety guidelines.

About this task

CAUTION:

1. To lift and install the enclosure into the rack requires at least two people.
2. Load the rack from the bottom to ensure rack stability. Empty the rack from the top down.

Following your enclosure location plan, install the correct type of enclosure starting from the bottom.

1. On either side of the drive assemblies, remove the enclosure end caps by squeezing the middle of the cap and pulling it away from the front of the enclosure.



Figure 16. Removing the enclosure end cap

2. Align the enclosure with the front of the rack cabinet.
3. Carefully slide the enclosure into the rack along the rails until the enclosure is fully inserted.

Notes:

- a. The preinstalled rails on the sides of the enclosure must fit into the rack-mounted rails that you previously installed.
 - b. The rails are not designed to hold an enclosure that is partially inserted. The enclosure must always be in a fully inserted position.
 - c. Do not have more than one enclosure extended out of the rack at the same time to avoid the danger of the rack toppling over.
4. Insert a screw into the hole behind each enclosure end cap and tighten the screw.



Figure 17. Securing an enclosure to a rack cabinet

5. After matching each end cap's serial number to the serial number found on the rear of each enclosure, push the end caps back into position.
6. Repeat this procedure for each additional enclosure that you install.

Step 8. Installing the support rails for file module slides

Install the file module's support rails in the rack.

About this task

Review the documentation that comes with the rack cabinet for safety and cabling information. Before you install the file module in a rack cabinet, review the following guidelines:

- Two or more people are required to install devices 2U or larger in a rack cabinet.
- Make sure that the room air temperature is below 35°C (95°F).
- Do not block any air vents; usually 15 cm (6 inch) of space provides proper airflow.
- Do not leave open spaces above or below an installed file module in the rack cabinet. To help prevent damage to file module components, always install a blank filler panel to cover the open space and to help ensure proper air circulation.
- Install the file module only in a rack cabinet with perforated doors.
- Plan the device installation starting from the bottom of the rack cabinet.
- Install the heaviest device in the bottom of the rack cabinet.
- Do not extend more than one device out of the rack cabinet at the same time.
- Remove the rack doors and side panels to provide easier access during installation.
- Do not overload the power outlet when you install multiple devices in the rack cabinet.
- Install the file module in a rack that meets the following requirements:

- Minimum depth of 70 mm (2.76 inch) between the front mounting flange and inside of the front door.
- Minimum depth of 157 mm (6.18 inch) between the rear mounting flange and inside of the rear door.
- Minimum depth of 718 mm (28.27 inch) and maximum depth of 762 mm (30 inch) between the front and rear mounting flanges to support the use of the cable management arm.

Note: The maximum distance between the front and the rear EIA rails of the rack is 810 mm (31.9 inch). Also, cage nuts and clip nuts are not required to install the file module in a rack cabinet.

- Install the cable management arm on either side of the file module. These instructions are shown with the cable management arm mounted on the left side. The installation instructions in this document can be reversed if you are installing the cable management arm on the side of the file module not shown.

The following illustration shows the items that you need to install the file module in the rack cabinet. If any items are missing or damaged, contact your place of purchase. The contents from the slide rail box and the cable management arm box are necessary for this installation.

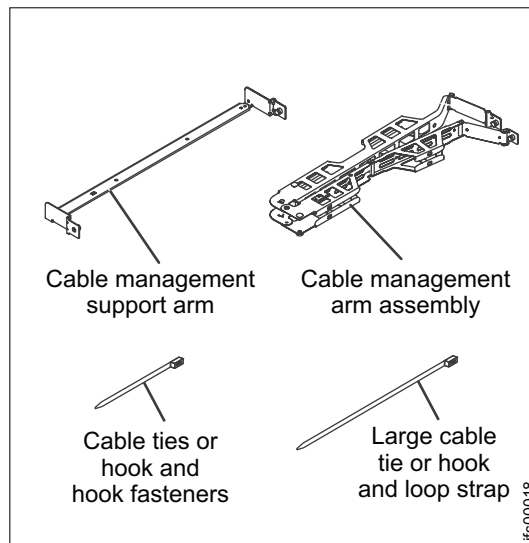

Figure 18. Cable management arm box contents.

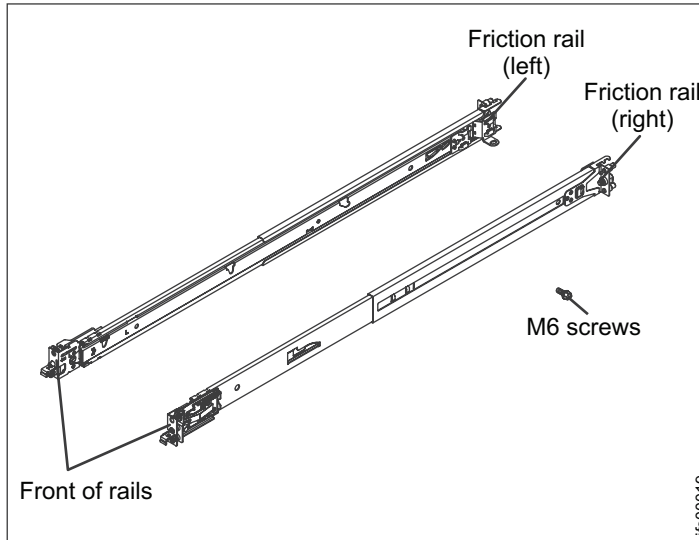

Figure 19. Friction rail box contents.

If the slide rails in your rack installation kit came with shipping thumbscrews, remove them before you begin the following installation procedure.

Follow these installation instructions:

1. Select an available 2U space in the rack to install the file modules.

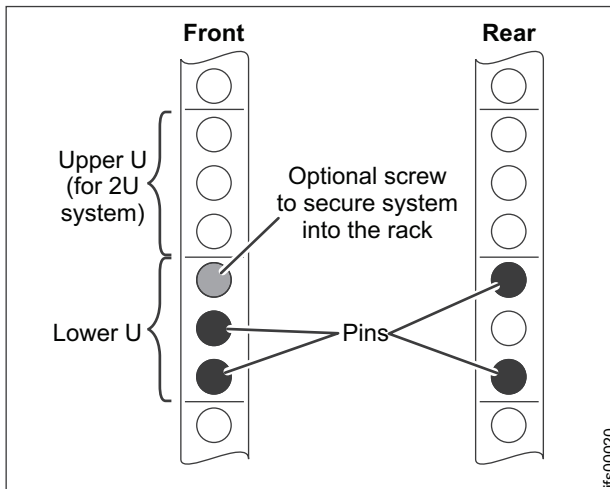

Figure 20. Locate a 2U space in the lower section of the rack.

2. Each slide rail is marked with either an R (right) or an L (left). Select one of the slide rails and pull the rear bracket all the way back. If a thumbscrew is installed in the slide rail, remove it.

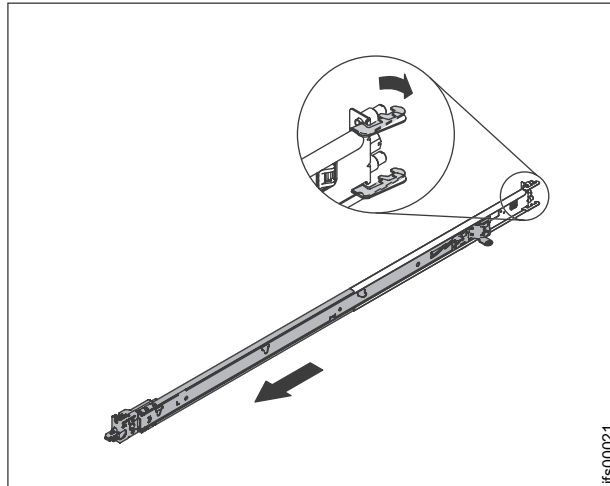

Figure 21. Open the rear slide rail hooks.

3.

Note: If you are installing the slide rails into a 1U space with devices already installed directly above and below this 1U space, you need to extend the slide rails to slide the rear of the slide rails into the rear of the rack. When installing a 2U device, be sure to install the slide rails in the bottom position of the 2U area in the rack.

From the front of the rack, line up the two pins on the rear of the slide rail in the selected unit on the rear of the rack. Push the rails so that the pins go into the holes and slide the rails into the rack to lock the rear of the slide rails into the rack.

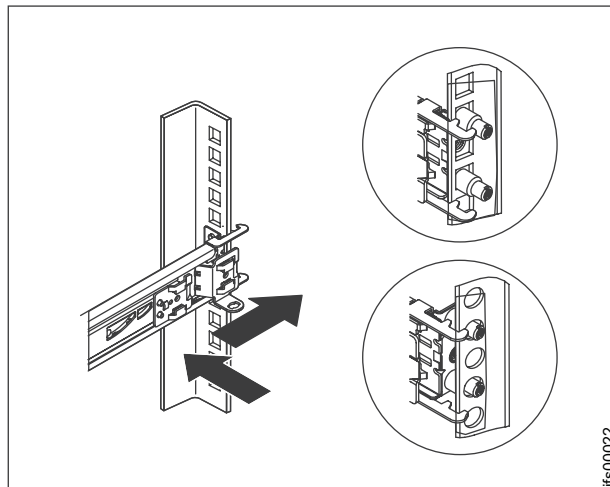

Figure 22. Install the rear end of the slide rails.

4. Push the blue button to allow the latch to slide forward. Then pull the slide rail forward and locate the front latch in the appropriate unit space in front of the rack EIA rail. Adjust the length of the rail.

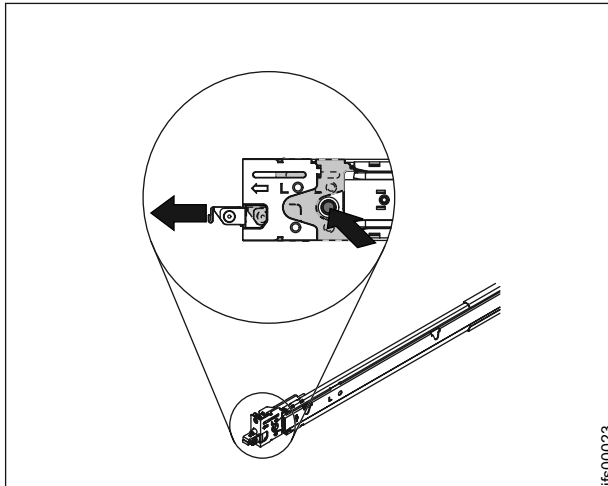

Figure 23. Install the front end of the slide rails.

5. Press the blue button to release the bracket. Push the front latch in all the way. Make sure the latch is fully engaged. Repeat steps 1 through 5 to install the other rail into the rack. Make sure that each front latch is fully engaged.

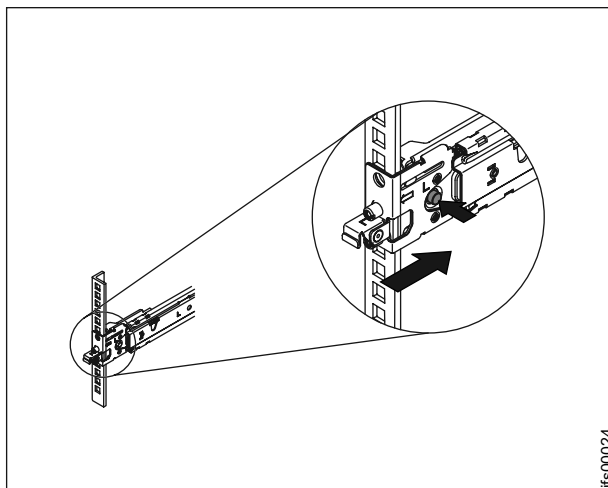

Figure 24. Install the front end of the slide rails.

Step 9. Installing the file modules

Install the file modules in the rack following the safety guidelines.

About this task

To install each file module in the rack, follow these instructions:

1. Pull the slide rails forward **1** until they click, two times, into place. Carefully lift the file module and tilt it into position over the slide rails so that the rear nail heads **2** on the device line up with the slide rails. Slide the file module down until the rear nail heads slip into the two rear slots, and then slowly lower the front of the file module **3** until the other nail heads slip into the other slots on the slide rails.

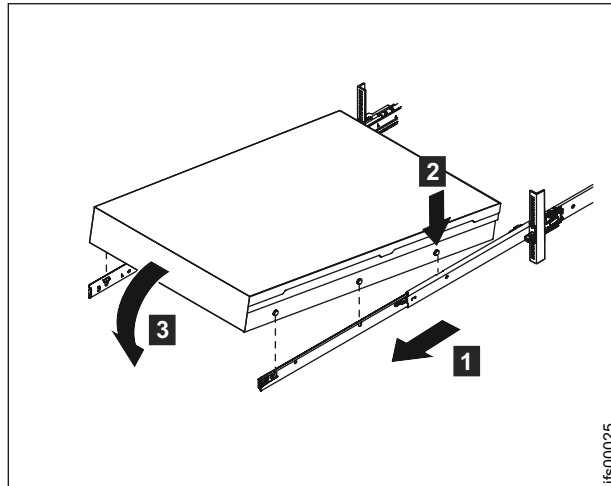

Figure 25. Install the file module on the slide rails.

2. Lift the locking levers **1** on the slide rails and push the file module **2** all the way into the rack until it clicks into place.

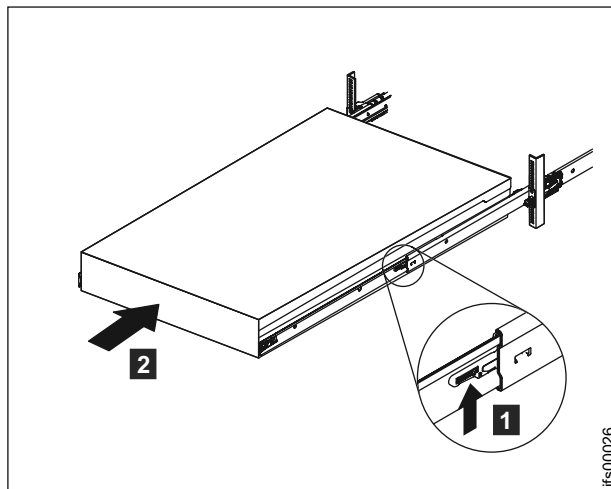

Figure 26. Slide the file module into the rack.

3. Insert both ends of the cable management support arm to the slide rail.

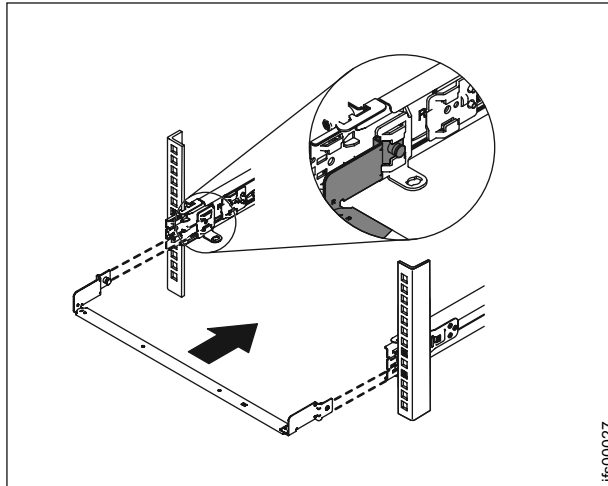

Figure 27. Install the cable management support arm. It can be installed on either side (left or right). The graphic shows the rear of the rack.

4.

Note: Make sure the arm with junctions is facing the file module. Place the cable management arm on the support arm. Pull out both cable management arm pins and then slide the cable management arm tabs into the slots on both inside and outside of the slide rail. Push the tabs until they snap into place.

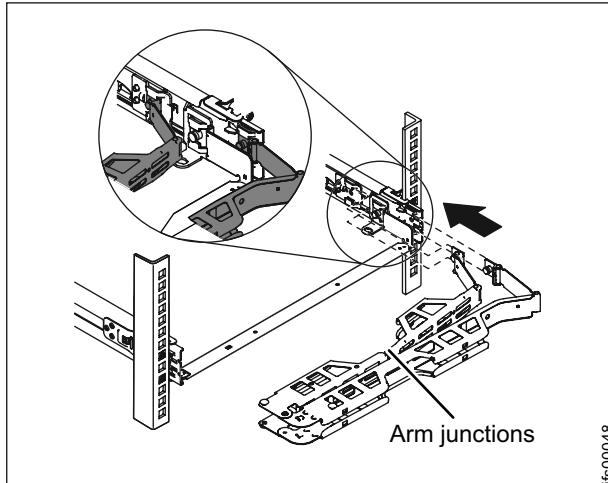

Figure 28. Install the cable management arm.

5. Make sure that the support rail is located between the 2 nail head features.

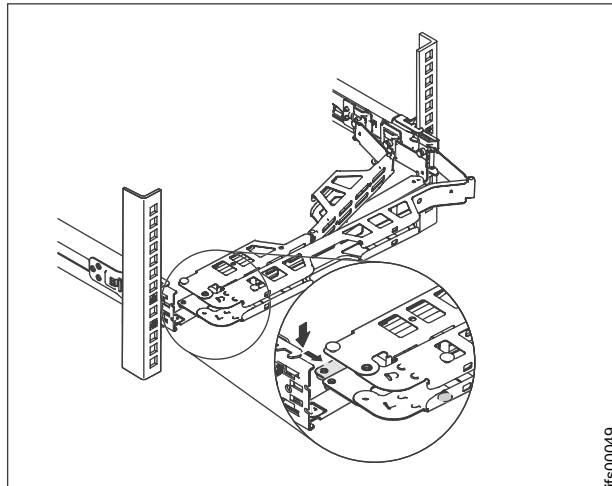

Figure 29. Adjust the location of the cable management arm.

6. Attach the power cords and other cables to the rear of the file module (including keyboard, monitor, and mouse cables, if required).
Route the cables and power cords on the cable management arm **1** and secure them with cable ties or hook-and-loop fasteners.

Note: Allow slack in all cables to avoid tension in the cables as the cable management arm moves.

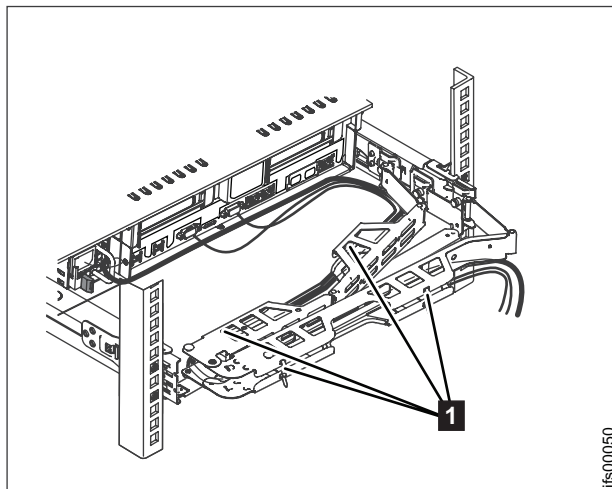

Figure 30. Connect and route the cables.

7. Insert the M6 screws to the rear of the slides. Use a cable tie to secure the free end of the cable management arm to the rack, if needed.

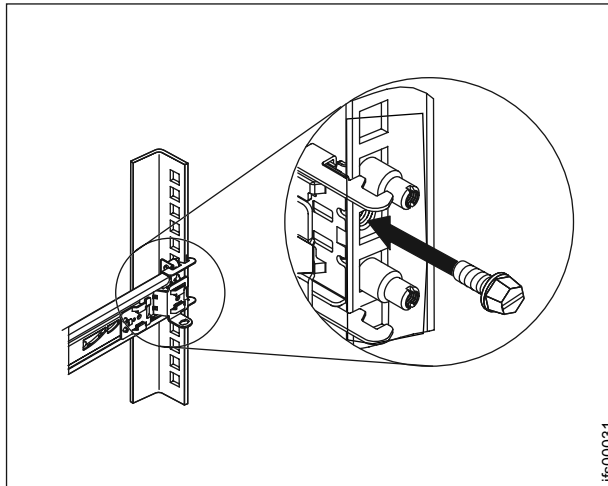

Figure 31. Secure the cable management arm and the file module in the rack for shipping if needed.

8. Slide the file module into the rack until it snaps into place. To slide the file module out of the rack, press on the release latches **1**.

Note: When you move the rack cabinet, or if you install the rack cabinet in a vibration-prone area, insert the M6 screws **2** in the front of the file module.

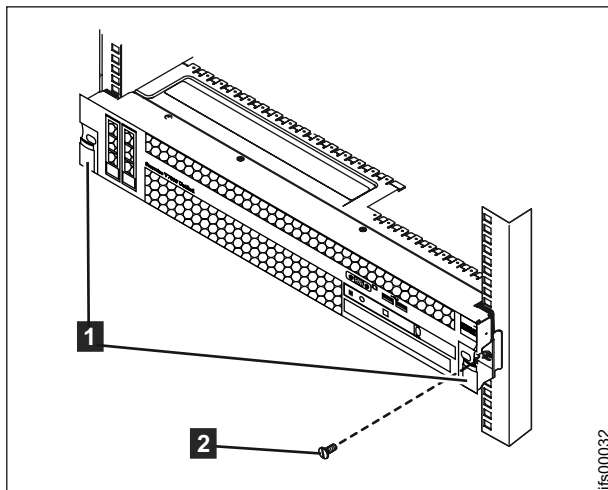

Figure 32. Install the front screws.

Step 10. Connecting the SAS cables to the expansion enclosures

Connect the SAS cables to the expansion enclosures.

About this task

This task applies if you are installing one or more expansion enclosures.

Note: The enclosure terminology that is used in this topic is described fully in “Step 2. Identifying the hardware components” on page 3.

Be aware of these guidelines when you begin to attach the cables to the SAS ports:

- No more than five expansion enclosures can be chained to port 1 (below the control enclosure). The connecting sequence from port 1 of the node canister is called chain 1.
- No more than four expansion enclosures can be chained to port 2 (above the control enclosure). The connecting sequence from port 2 of the node canister is called chain 2.
- No cable can be connected between a port on an upper canister and a port on a lower canister.
- Attach cables serially between enclosures; do not skip an enclosure.
- The last enclosure in a chain must not have cables in port 2 of canister 1 and port 2 of canister 2.
- Ensure that cables are installed in a tidy manner to reduce the risk of cable damage when Storwize V7000 Unified replaceable units are removed or inserted.
- Arrange your cables to provide access to:
 - The USB ports. Access is required to this port when you use the USB flash drive to configure the system.
 - The enclosures themselves. Access is required to the hardware for servicing and for safely removing and replacing components using two or more people.
- Ensure that each SAS cable is fully inserted. A click is heard when the cable is successfully inserted.

Note: If you make a mistake during cabling and must unplug a SAS cable, pull the blue tag to release the cable.

The following table refers to Figure 33 on page 44.

Table 13. Use this table to identify the file module, control enclosure, and expansion unit port locations. Follow the links to identify detailed port locations.

Key	Description	
A	Control enclosure. This unit consists of two canisters; the upper and the lower. The lower canister is position upside down. See Figure 3 on page 4 for detailed port locations.	1 SAS port 1 2 SAS port 2 3 SAS port 1 4 SAS port 2
B	Expansion enclosure. This configuration is for enclosure units 1, 3, 5. This unit consists of two canisters; the upper and the lower. The lower canister is position upside down. See Figure 6 on page 6 for detailed port locations.	Note: All port locations are identical for B through C 5 SAS port 1 6 SAS port 2 The lower unit is upside down: 7 SAS port 2 8 SAS port 1
C	Expansion enclosure. This configuration is for enclosure units 2, 4, 6. This unit consists of two canisters; the upper and the lower. The lower canister is position upside down. See Figure 6 on page 6 for detailed port locations.	Ports are identical to B .

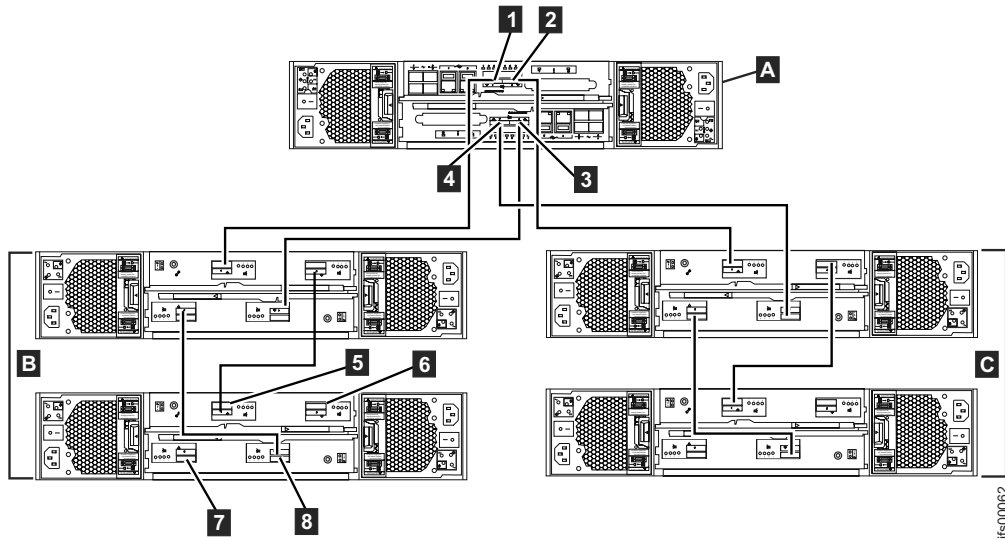

Figure 33. Internal cabling connections between the control enclosure (A) and the expansion enclosures (B & C).

Procedure

1. Review Table 14 and the figures before attaching the SAS cables. The table below refers to Figure 33.

Table 14. How to connect SAS cables to expansion units.

SAS Connections: How the first unit connects to the second unit		
First Unit	Second Unit	Number of Expansions
Controller	Expansion 1	1 Expansions
Upper canister port 1	Upper canister port 1	
Lower canister port 1	Lower canister port 1	
Controller	Expansion 2	2 Expansions
Upper canister port 2	Upper canister port 1	
Lower canister port 2	Lower canister port 1	
Expansion 1	Expansion 3	3 Expansions
Upper canister port 2	Upper canister port 1	
Lower canister port 2	Lower canister port 1	
Expansion 2	Expansion 4	4 Expansions
Upper canister port 2	Upper canister port 1	
Lower canister port 2	Lower canister port 1	
Expansion 3	Expansion 5	5 Expansions
Upper canister port 2	Upper canister port 1	
Lower canister port 2	Lower canister port 1	
Expansion 4	Expansion 6	6 Expansions
Upper canister port 2	Upper canister port 1	
Lower canister port 2	Lower canister port 1	
Expansion 5	Expansion 7	7 Expansions
Upper canister port 2	Upper canister port 1	

Table 14. How to connect SAS cables to expansion units. (continued)

SAS Connections: How the first unit connects to the second unit		
First Unit	Second Unit	Number of Expansions
Lower canister port 2	Lower canister port 1	
Expansion 6	Expansion 8	8 Expansions
Upper canister port 2	Upper canister port 1	
Lower canister port 2	Lower canister port 1	
Expansion 7	Expansion 9	9 Expansions
Upper canister port 2	Upper canister port 1	
Lower canister port 2	Lower canister port 1	

- Attach the SAS cables from the control enclosure to the first expansion enclosure as shown in Figure 34. Remove the protective end covers, if necessary. The first expansion enclosure is below the control enclosure.

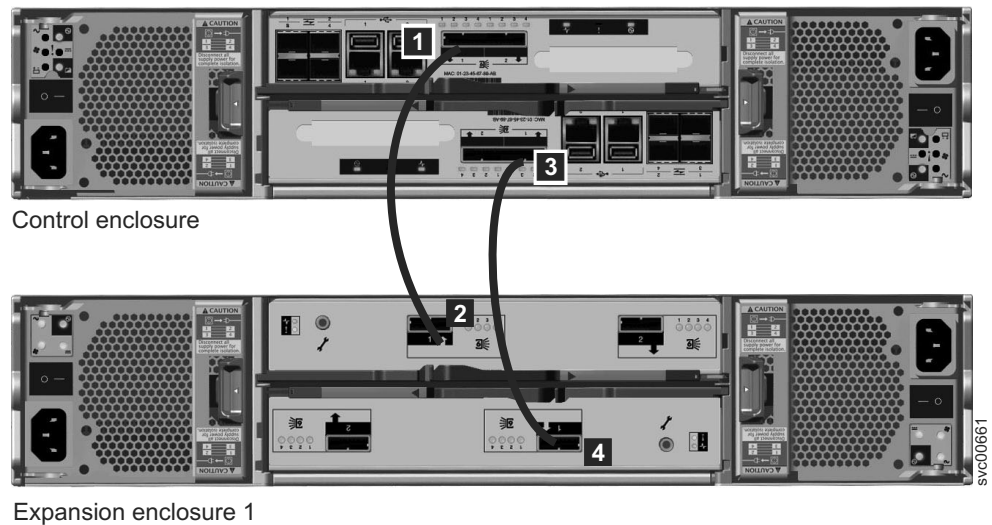

Figure 34. Attaching an expansion enclosure to the control enclosure

- Port 1 **1** of the upper canister, control enclosure, attaches to Port 1 **2** of the upper canister, expansion enclosure 1.
- Port 1 **3** of the lower canister, control enclosure, attaches to Port 1 **4** of the lower canister, expansion enclosure 1. The port locations on the lower canister are inverted from the port locations on the upper canister. Port 1 on the lower canister is opposite port 1 on the upper canister.

Note: The connecting sequence from port 1 of the node canister is called chain 1.

- Attach the SAS cables from the control enclosure to the second expansion enclosure as shown in Figure 35 on page 46. The second expansion enclosure is above the control enclosure.

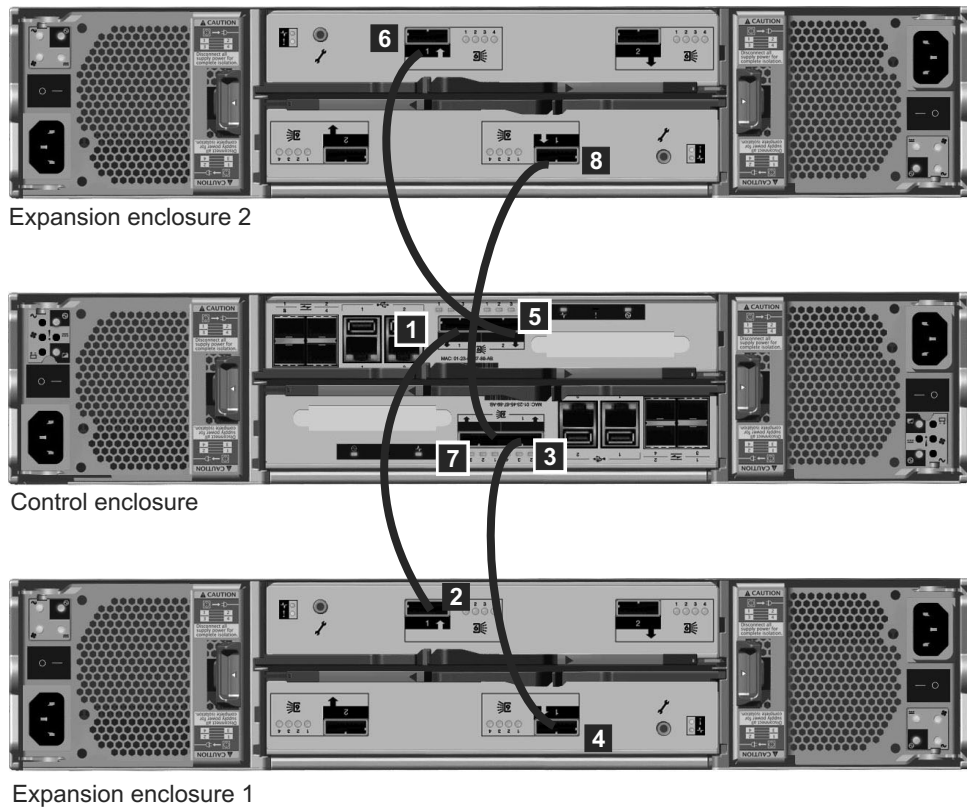

Figure 35. Adding a second expansion enclosure

- a. Port 2 **5** of the upper canister, control enclosure, attaches to Port 1 **6** of the upper canister, expansion enclosure 2.
- b. Port 2 **7** of the lower canister, control enclosure, attaches to Port 1 **8** of the lower canister, expansion enclosure 2. The port locations on the lower canister are inverted from the port locations on the upper canister. Port 1 on the lower canister is opposite port 1 on the upper canister.

Note: The connecting sequence from port 2 of the node canister is called chain 2.

4. Attach the SAS cables from the first expansion enclosure to the third expansion enclosure.

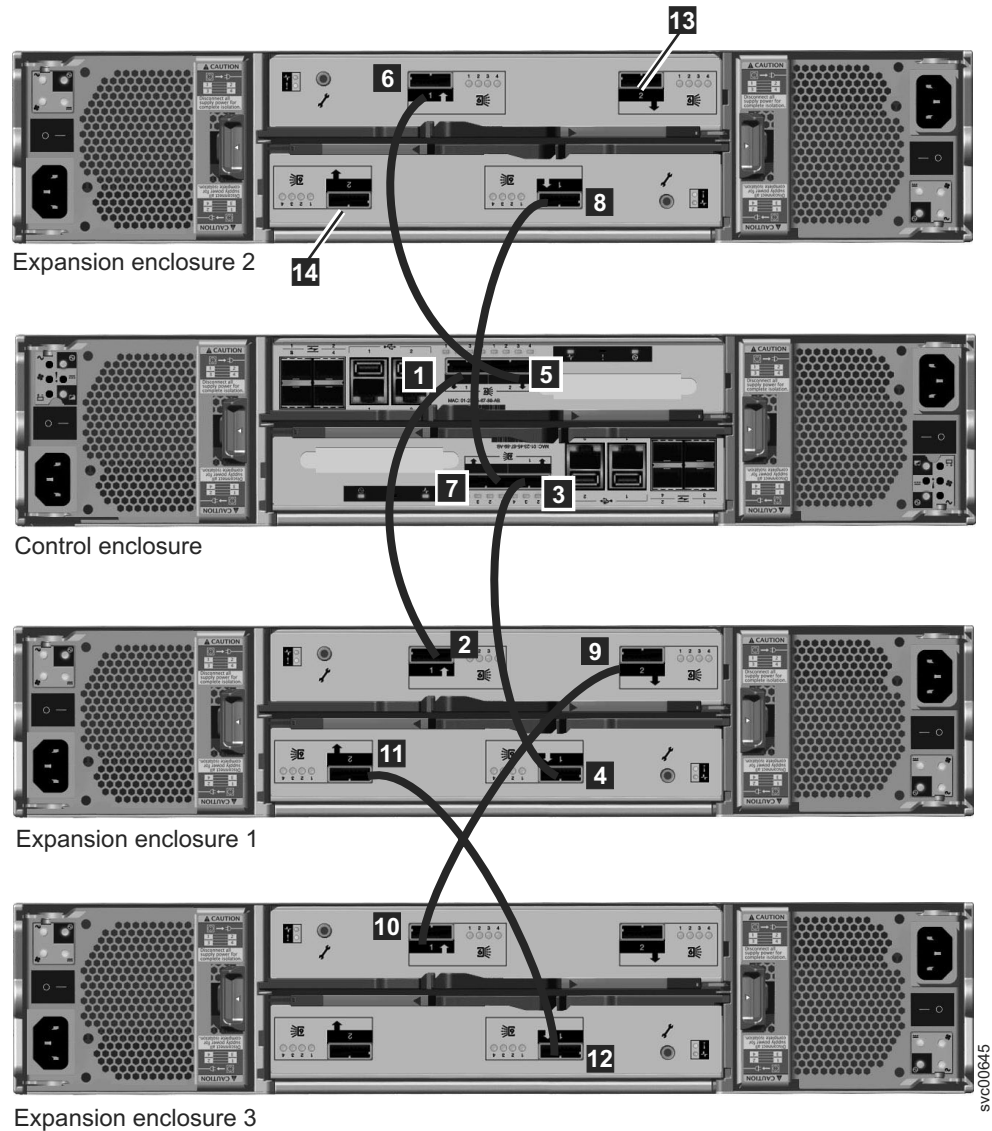

Figure 36. Attaching SAS cables to the enclosures

- a. Port 2 **9** of the upper canister, expansion enclosure 1, attaches to Port 1 **10** of the upper canister, expansion enclosure 3.
- b. Port 2 **11** of the lower canister, expansion enclosure 1, attaches to Port 1 **12** of the lower canister, expansion enclosure 3.
5. Attach SAS cables for additional expansion enclosures. You can add up to nine expansion enclosures. You add a fourth expansion enclosure at **13** and **14** on expansion enclosure 2.
 - a. Add the enclosures alternately to chain 1, and then chain 2.
 - b. Use port 2 on the canisters that are already connected to attach to port 1 on the canisters of the enclosures that you want to add.
6. Verify your cabling.

Step 11. Attaching the Ethernet cables

Attach the Ethernet cables to the control enclosure and any expansion enclosures.

About this task

This task guides you through connecting both the internal and external Ethernet connections for your system.

This task assumes that your initial planning has determined where the Ethernet cables are to be located. The Storwize V7000 Unified control enclosure requires at least one and a maximum of two 1 Gbps Ethernet connections. Refer to Figure 37, Figure 38 on page 49, and Table 15 on page 49. For the file modules, the first two 1 Gbps Ethernet ports labelled **1** and **2** in Figure 39 on page 50 are used for internal communications between the file modules. The third and fourth 1 Gbps Ethernet ports are used for management and data (if needed). All 10 Gbps Ethernet ports are dedicated to data. Management cannot be performed over the 10 Gbps Ethernet. Refer to Figure 39 on page 50 and Table 16 on page 50.

Note: It is important that the file modules are able to communicate over the network with the Storwize V7000 control enclosure for management, service and optional file access.

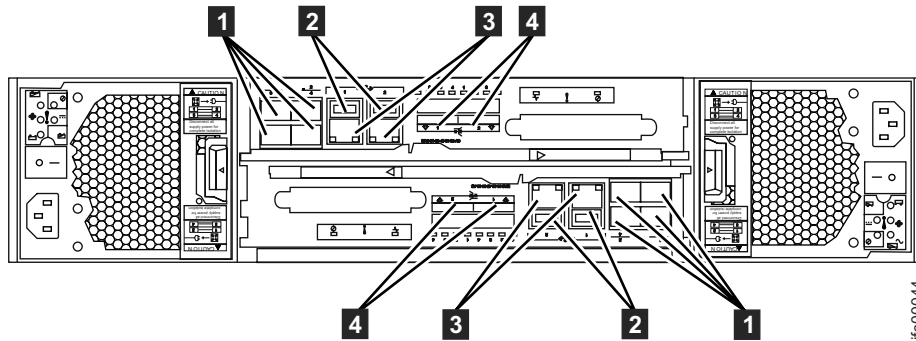
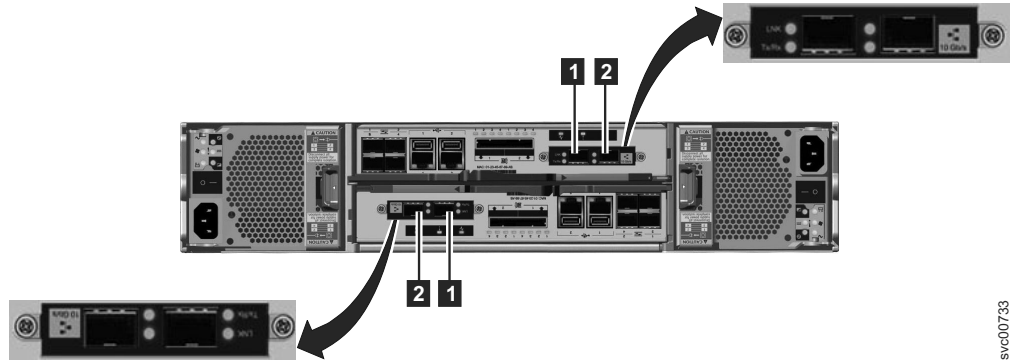

Figure 37. Control enclosure Ethernet network connections.

- **1** Fibre Channel ports (8 Gbps). Each canister has four Fibre Channel ports. They are in a block of four in two rows of two connectors. The ports are numbered 1 - 4 from left to right, top to bottom. Two ports connect to the file modules and two are connected to the SAN.
- **2** USB ports. Each canister has two USB ports. The ports are side by side on the canister and are numbered 1 on the left and 2 on the right. One port is used during installation.
- **3** Ethernet ports (1 Gbps). Each canister has two Ethernet ports. The ports are side by side on the canister. They are numbered 1 on the left and 2 on the right on the upper canister. The port locations are inverted for the lower canister. Port 1 must be connected first; the use of port 2 is optional.
- **4** Serial-attached SCSI (SAS) ports (6 Gbps). Each canister has two SAS ports. The ports are side by side on the canister. They are numbered 1 on the left and 2 on the right. Port 1 must be connected first if you are adding one expansion enclosure. Port 2 must be connected if you are adding a second expansion enclosure.



sv000733

Figure 38. 10 Gbps Ethernet ports on the rear of the Storwize V7000 enclosure

- **1** 10 Gbps Ethernet port 3 which is the left port.
- **2** 10 Gbps Ethernet port 4 which is the right port.

Table 15. Ethernet connections available with the control enclosure

Item	Port	Purpose	IP address is assigned by InitTool	Use
3 (left port, Figure 37 on page 48)	Built-in Ethernet port 1	1 Gbps external network connection	Yes	Management and service port for each canister, optional iSCSI. (The Storwize V7000 control enclosure must be able to communicate over the network with the file modules.)
3 (right port Figure 37 on page 48)	Built-in Ethernet port 2	1 Gbps external network connection	No	Optional management and service port, optional iSCSI
1 (Figure 38)	Ethernet port 3 on a 2076-312 or 2076-324	10 GbE external network connection	No	Optional iSCSI
2 (Figure 38)	Ethernet port 4 on a 2076-312 or 2076-324	10 GbE external network connection	No	Optional iSCSI

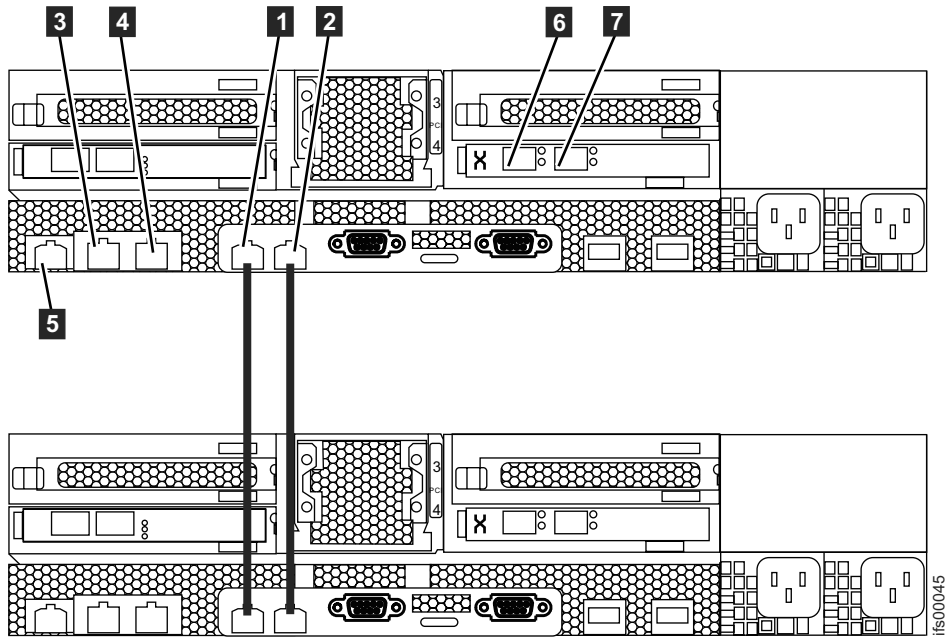

Figure 39. File module Ethernet direct connections.

Table 16. Ethernet connections available with the file modules

Item	Port	Purpose	IP address is assigned by InitTool	Use
1	Built-in Ethernet port 2	1 Gbps file module to file module interconnect	From the range	File module to file module configuration mirroring
2	Built-in Ethernet port 1	1 Gbps file module to file module interconnect	From the range	File module to file module configuration mirroring
3	Built-in Ethernet port 3	1 Gbps external network connection	Yes	Management, service and optional file access. (The file modules must be able to communicate over the network with the Storwize V7000 control enclosure.)
4	Built-in Ethernet port 4	1 Gbps external network connection	No	Optional management, optional service, optional file access

Table 16. Ethernet connections available with the file modules (continued)

Item	Port	Purpose	IP address is assigned by InitTool	Use
5	IMM Ethernet port	Ethernet link to the system X Integrated Management Module	No	Not supported
6	PCI slot 4, port 1	10 GbE external network connection	No	Optional file access
7	PCI slot 4, port 0	10 GbE external network connection	No	Optional file access

Attention: The default service IP addresses on your new Storwize V7000 Unified control enclosure might conflict with existing devices that are attached to the network or with other new control enclosures that you are installing. The service IP address 192.168.70.121 subnet mask 255.255.255.0 is preconfigured on Ethernet port 1 of the upper canister, canister 1. The service IP address 192.168.70.122 subnet mask 255.255.255.0 is preconfigured on Ethernet port 2 of the lower canister, canister 2.

If you encounter that situation, change the service IP addresses on the new nodes before connecting the Ethernet cables. For details, see Figure 39 on page 50 or see the *Storwize V7000 Unified Problem Determination Guide* PDF on the DVD for further information about setting service IP addresses using a USB flash drive.

Perform the following steps:

1. For each node canister in the control enclosure, connect an Ethernet cable between Ethernet port 1 of the canister and the Ethernet network.

Note: Ethernet cables are not supplied as part of your order. A CAT 5 unshielded twisted pair (UTP) is the minimum requirement for an Ethernet cable.

Ensure that cables are installed in a tidy manner to reduce the risk of cable damage.

2. Optionally attach Ethernet cables between Ethernet port 2 on each node canister and your Ethernet network.

File module to file module:

- Connect an Ethernet cable from Ethernet port 1 on the first file module to the first Ethernet port on the second file module. Refer to Figure 39 on page 50 for port locations.

Note: Ethernet cables for the internal network are provided by IBM with the file modules.

- Connect an Ethernet cable from Ethernet port 2 on first file module to Ethernet port 2 on the second file module.
- Route the Ethernet cables through the cable management arms, and secure any excess using the cable retention features of the rack.

File module management ports:

- Connect an Ethernet cable from Ethernet port 3 on the first file module to an Ethernet network. If using two Ethernet cables (as recommended), connect another Ethernet network cable to Ethernet port 4. When using only one Ethernet port, the network status is marked as degraded and an associated warning event is listed in the health center.
- Repeat the previous step for the second file module.
- Route the Ethernet cables through the cable management arm, and secure any excess using the cable retention features of the rack.

File modules to external (host ports) network (10 GB Fibre Ethernet):

You have two 10 Gbps Fibre Ethernet ports available for host connections from each file module. The ports are on the PCI card located in slot 4. Connect your network cables to the Ethernet ports in these slots as applicable. Refer to Figure 39 on page 50.

Step 12. Attaching the Fibre Channel cables

Attach the Fibre Channel cables from the file modules to the control enclosure.

About this task**File modules:**

To attach the Fibre Channel cables, perform the following steps:

- Connect two Fibre Channel cables from the first file module to the control enclosure. Be sure to plug one cable into one node canister on the control enclosure and the other cable into the other node canister for redundancy. Route the Fibre Channel cables through the Cable Management Arms.

Note: Fibre Channel cables are provided by IBM with the file modules.

- Repeat the previous step for the other file module.
- Before continuing, make sure that you have connected the Fibre Channel cabling as shown in Figure 40 on page 53 to ensure proper redundancy. Incorrect cabling may result in a loss of service during system maintenance procedures.
- Secure any excess cable length using the cable retention features of the rack.

Note: After the blue indicator light appears when the file modules are powered on, the amber LED (with the number 8 stamped on the metal next to each Fibre Channel port) should be lit to show that the link speed is 8 Gbps.

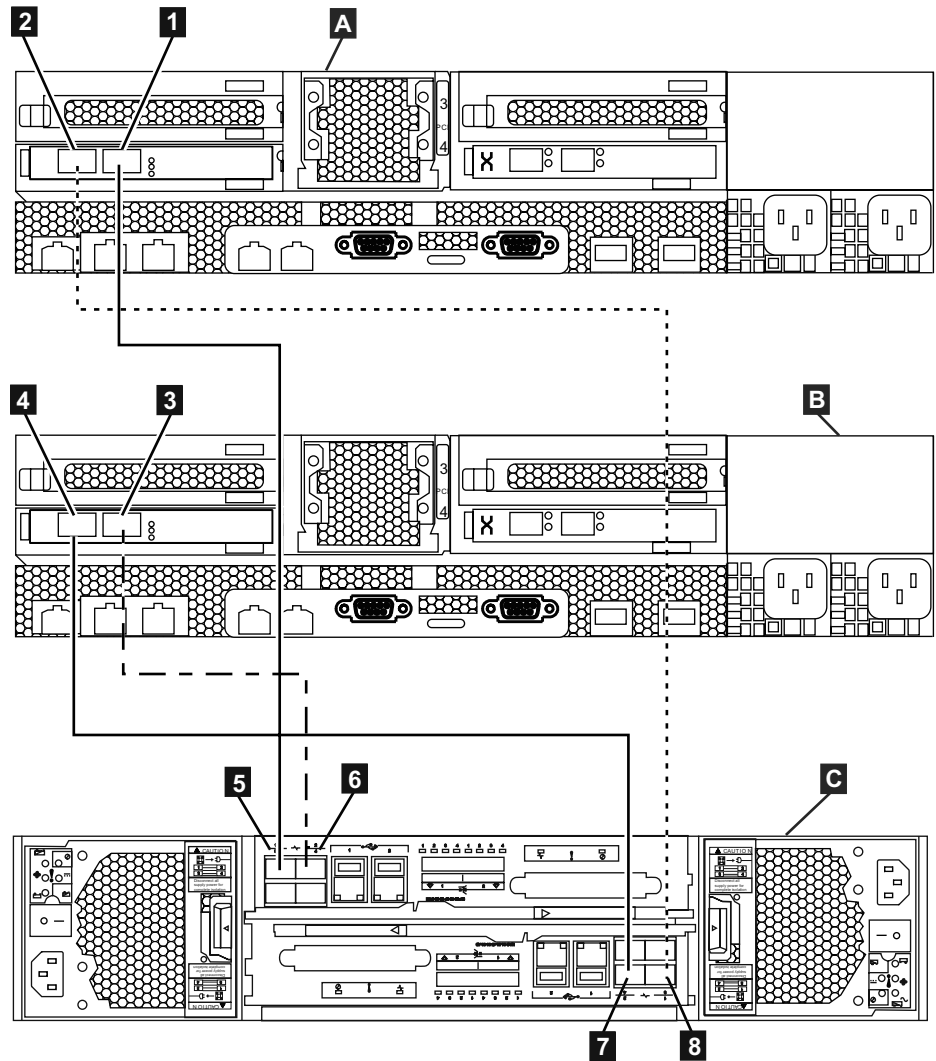

Figure 40. Diagram showing how to connect the file modules to the control enclosure using Fibre Channel cables. Refer to previous table.

- **A** File module 1
- **B** File module 2
- **C** Storwize V7000 control enclosure
- **1** File module1 - Fibre Channel port 1
- **2** File module 1 - Fibre Channel port 2
- **3** File module 2 - Fibre Channel port 1
- **4** File module 2 - Fibre Channel port 2
- **5** Upper node canister - Fibre Channel port 1
- **6** Upper node canister - Fibre Channel port 2
- **7** Lower node canister - Fibre Channel port 2
- **8** Lower node canister - Fibre Channel port 1

2 = 3 = 4 = 5 = 6 = 7 = 8 =

Note: If you want this control enclosure to communicate with other Storwize V7000 control enclosures, storage controllers, the Storwize V7000 Unified or block

hosts, then connect the Fibre cables from your Fibre Channel switch to the remaining node canisters Fibre Channel ports 3 and 4.

Step 13. Connecting the power cords

Connect the power cords to the power supply units.

About this task

Control enclosure:

Two power supply units are located in each enclosure. Ensure that the power switches for the control enclosure and expansion enclosures power supply unit are switched off.

Note: Each power supply unit comes with an attached cable retention bracket that fastens around the power cord to prevent the cord from being removed accidentally.

Perform the following steps when you attach the power cord to each power supply unit:

1. Straighten the cable tie on the cable retention bracket. The cable retention bracket is attached to the power supply unit.
2. Open the cable retention bracket.



syc00686

Figure 41. Unlocking the cable retention bracket

3. Slide the cable retention bracket away from the power supply unit until there is enough room to attach the cable retention bracket to the cable. When sliding the bracket away from the cable plug-in, pull the lever on the bracket that controls the cable tie slightly towards the center of the canister. You do not need to pull the lever to slide the bracket towards the cable plug-in.
4. Attach a power cord to each of the two power supply units in each enclosure. Ensure that cables are installed in a tidy manner to reduce the risk of cable damage when Storwize V7000 Unified replaceable units are removed or inserted.
5. Place the cable retention bracket around the end of the cable that plugs into the power supply unit.
6. Slide the cable retention bracket along the cord until it fits snugly against the plug end of the cable.

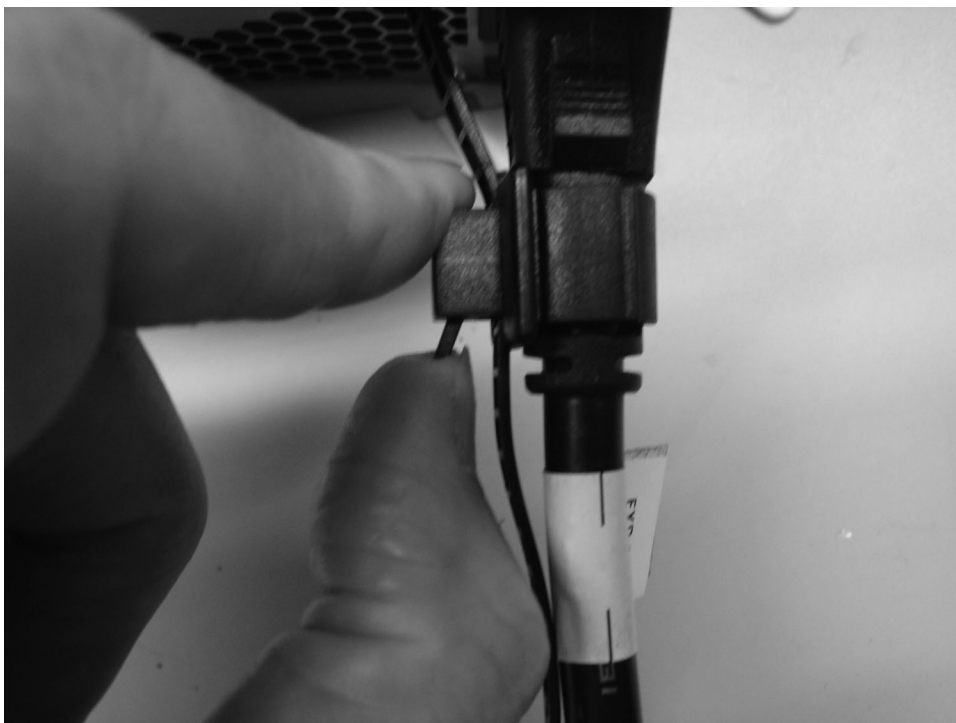

svc00644

Figure 42. Sliding the cable retention bracket directly behind the power cord

7. Tighten the fastener around the plug.
8. Repeat the steps for each additional power cord.
9. Plug the power cords into a properly grounded electrical outlet. To provide power failure redundancy, plug the power cords for the individual power supply units for each enclosure into separate power distribution units, if possible.

File modules:

Perform the following steps when you attach the power cord to each power supply unit:

1. Connect two power cords from a file module rack power supply. Plugging them into separate Power Distribution Units (PDUs) is recommended for redundancy. Route the power cords through the Cable Management Arms.
2. Repeat the previous step for the other file module.
3. Secure any excess cable length using the cable retention features of the rack.

Step 14. Powering the system on and off

Power on the system after the cables and power cords are properly installed.

About this task

Follow the procedures for powering on the expansion enclosure and file modules, and in the order specified.

Attention: Do not operate the system when the drive assemblies are missing. Drive assemblies that are missing disrupt the airflow; the drives do not receive sufficient cooling. You must insert blank carriers into unused drive bays.

Powering on an expansion enclosure:

1. Power on the newly installed enclosures. Use the power switch on each of the two power supply units in the back of the expansion enclosure.
2. Use the information in Table 18 on page 58 to verify the state of the light emitting diodes (LEDs) on the system. Verify that no faults are detected. See the *Storwize V7000 Unified Problem Determination Guide* PDF on the CD if problems are encountered.

Both Figure 43 and Figure 44 show the location of the LEDs on the power supply units, located at the front of the expansion enclosure. Figure 45 on page 58 shows the location of the LEDs on the power supply units, located at the rear of the expansion enclosure. The LEDs are located at position **1**.



Figure 43. 24 drives and two end caps

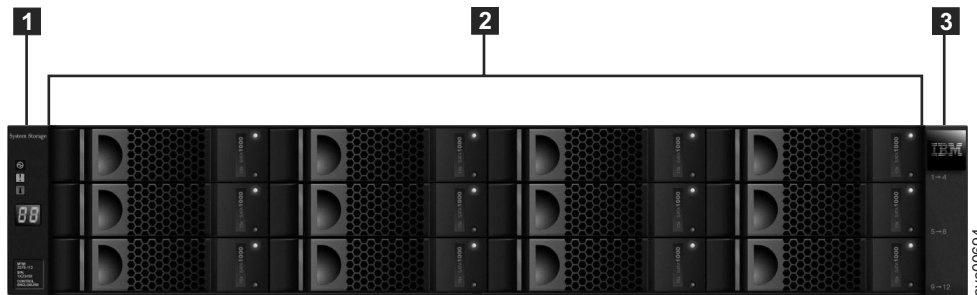

Figure 44. 12 drives and two end caps

Table 17. LED status front of control enclosure or expansion enclosure. Refers to item [1] in the figures above.

Hardware component	LED name and symbol	If power on and no fault is detected
Left enclosure end cap, front of enclosure	Power, top	LED is on.
	Fault, middle	LED is off.
	Identify, bottom	LED is off.

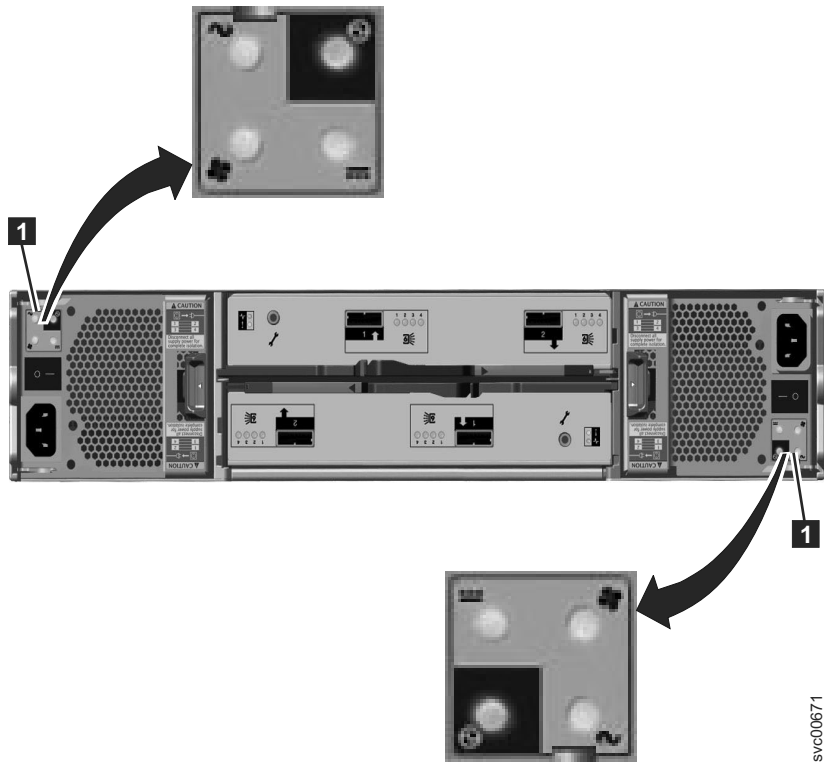







Figure 45. LEDs on the power supply units of the expansion enclosure

Table 18. LED status rear of expansion enclosure.

Hardware component	LED name and symbol	If power on and no fault is detected
Expansion canister, rear. The reference to the top and bottom locations applies to canister 1, which is the upper canister. The LED locations are inverted for canister 2, which is the lower canister.	Canister status, top 	LED is on.
	Fault status, bottom 	LED is off.
	SAS ports	When a SAS port is functioning correctly, all four green LEDs above the port are on. If no cable is plugged into the port, or if the canister at either end of the cable is not yet fully started, the LEDs are not on.
Power supply unit, expansion enclosure. The reference to the left and right locations applies to power supply unit 1, which is the left power supply. The LED locations are inverted for power supply unit 2, which is the right power supply.	Power supply, upper right 	LED is on.
	Fan failure 	LED is off.
	dc power failure 	LED is off.
	ac power failure 	LED is off.

Powering on a control enclosure:

1. Power on the control enclosure, if it is not already powered on and configured. Use the power switch on each of the two power supply units, located in the back of the enclosure.
2. Use Table 19 to verify the state of the LEDs on the system. Verify that no faults are detected.

Figure 46 shows the location of the LEDs on the power supply units in the rear of the control enclosure.

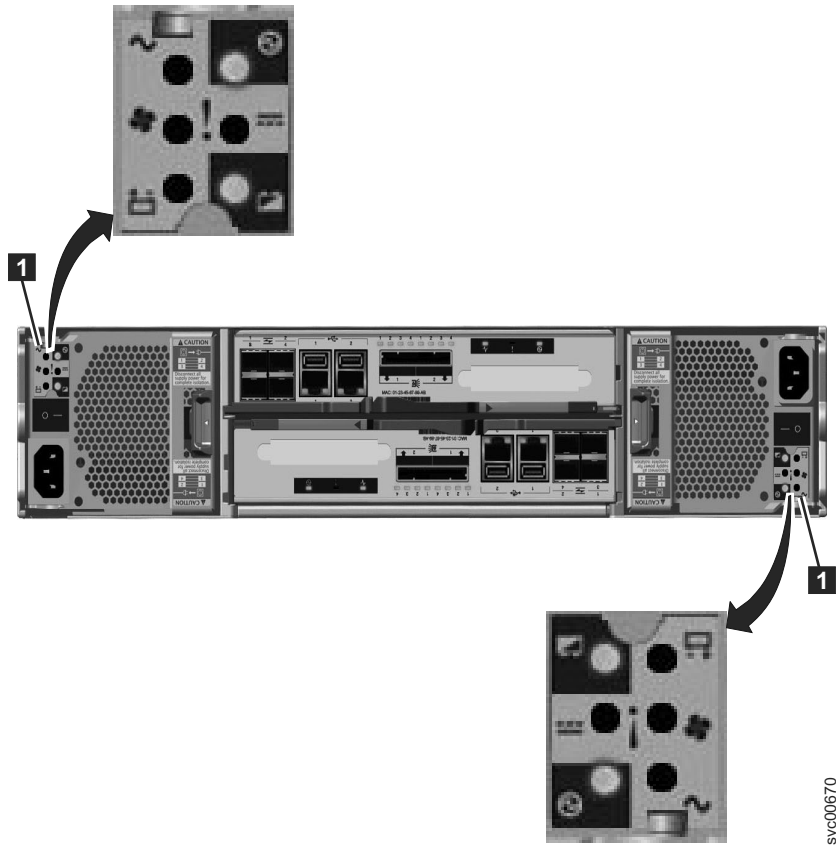

Figure 46. LEDs on the power supply units of the control enclosure

Table 19. LED status when control enclosure is powered on













Hardware component	LED name	If power on and no fault is detected
Left enclosure end cap, front of enclosure	Power, top 	LED is on.
	Fault, middle 	LED is off.
	Identify, bottom 	LED is off.

Table 19. LED status when control enclosure is powered on (continued)

Hardware component	LED name	If power on and no fault is detected
Node canister, rear. The reference to the top and bottom locations applies to canister 1, which is the upper canister. The LED locations are inverted for canister 2, which is the lower canister.	Fibre Channel port	If the Fibre Channel port is used: One or more LEDs are on or flashing per port. The LEDs are located between the Fibre Channel ports. The arrow-shaped LEDs point toward the affected port.
	Ethernet port, if used	One or more LEDs are on per port.
	SAS ports	When a SAS port is functioning correctly, all four green LEDs above the port are on. If no cable is plugged into the port, or if the canister at either end of the cable is not yet fully started, the LEDs are not on.
	System status, left 	LED is flashing or on. The status is on if the node canister is an active member of a clustered system. The LED is flashing if the node canister is in service or candidate state. If the LED is off, the node canister might still be booting up. Wait up to 5 minutes for the node canister to complete booting up.
	Fault status, middle 	LED is off.
	Power status, right 	LED is on.
Power supply unit, control enclosure. The reference to the left and right locations applies to power supply unit 1, which is the left power supply. The LED locations are inverted for power supply unit 2, which is the right power supply.	Power supply, upper right 	LED is on.
	ac power failure 	LED is off.
	dc power failure 	LED is off.
	Fan failure 	LED is off.
	Battery failure 	LED is off
Battery good, lower right 	LED is on or flashing.	

Attention: Do not go to the next section until the LEDs are in the required states. If any error lights are displayed, see the *Storwize V7000 Unified Problem Determination Guide* documentation CD for more information about light path issues.

See the IBM Storwize Problem Determination Guide PDF on the CD if problems are encountered.

File module power features:

When the file module is connected to a power source but is not turned on, the operating system does not run, and all core logic except for the integrated management module is shut down. However, the file module can respond to requests from the integrated management module, such as a remote request to turn on the file module. The power-on LED flashes to indicate that the file module is connected to power but is not turned on. The power on LED is found in the front of the file module.

Powering on the file module

Approximately 3 minutes after the file module is connected to power, the power-control button becomes active. Also, one or more fans might start running to provide cooling while the file module is connected to power. You can turn on the file module and start the operating system by pressing and releasing the power on button. The power on button is located at the front of the file module.

Turning off the file module

When you turn off the file module and leave it connected to power, the file module can respond to requests from the integrated management module. For example, it can respond to a remote request to turn on the file module. While the file module remains connected to power, one or more fans might continue to run. To remove all power from the file module, you must disconnect it from the power source.

Important: To view the error LEDs on the system board, leave the file module connected to a power source.

Some operating systems require an orderly shutdown before you turn off the file module. See your operating-system documentation for information about shutting down the operating system.

CAUTION:

The power on button on the device does not turn off the electrical current supplied to the device. The device also might have more than one power cord. To remove all electrical current from the device, ensure that all power cords are disconnected from the power source.

Press and release the power on button to start an orderly shutdown of the operating system and turn off the file module, if your operating system supports this feature

Attention: If you have a problem powering off the system, see the *Storwize V7000 Unified Problem Determination Guide* documentation CD for more information about light path issues.

Chapter 3. Initializing the system

This topic contains a set of instructions to help you initialize your system.

Step 15. Using InitTool.exe on the USB flash drive

The USB flash drive is required to initialize the system.

About this task

WARNING: You must check carefully that the IP addresses that you provide to InitTool.exe are valid and not already in use by some other system on the network apart from the gateway IP address. Refer to “Checking that IP addresses are not already in use” on page 11. If you provide an IP address that is already in use then the initial setup may appear to be successful and the system could work for some time before random problems start to happen which are very hard to troubleshoot.

Procedure

1. Locate the USB flash drive that was shipped with your order in the documentation package.

Note: You might encounter a problem where the code cannot be run if you use your own USB flash drive. The USB flash drive that you use must:

- Contain a FAT32 formatted file system on its first partition. NTFS and other file system types are not supported.
- Contain a copy of the Microsoft Windows USB flash drive InitTool.exe executable that is located in the root directory of the file system.
- Be write enabled.

2. Insert the USB flash drive into a USB port in a personal computer that is running Microsoft Windows XP Professional or higher.

If the system is configured to autorun for USB keys, the initialization tool starts automatically. Otherwise, open the USB flash drive from **My Computer** and double-click the InitTool.exe.

Note: If you are running a non-Windows operating system, skip to 4 on page 64.

3. Select the **Initialize a new Storwize V7000 Unified** option from the Welcome panel of the initialization tool. Click **Next**. Use the initialization tool to complete the following steps:

Note: See 4 on page 64 for details on IP addresses that are used in these steps.

- a. Enter the primary IP address of the Storwize V7000 system, netmask for this network subnet, and gateway IP addresses for this network subnet. Click **Next**.
- b. Enter the **Management IP** address, **File Module 1**, and **File Module 2** IP addresses. Then select an Internal IP address range that you are sure is not in use somewhere else in your network. Click **Next**.
- c. Read the instructions of what to do next on the final page. Click **Finish** on the Final Page and make sure that both the satask.txt and the cfgtask.txt file are on the USB flash drive. If the files are not on the USB flash drive refer to

USB key and Initialization tool interface located in the *Storwize V7000 Unified Problem Determination Guide* PDF on the DVD.

d. Proceed to “Step 16. Initialize the Storwize V7000.”

WARNING: If InitTool.exe does not ask you for the management IP, file module 1 IP, and file module 2 IP addresses. Then you are probably using the wrong version of InitTool.exe.

- If you are running a non-Windows operating system, you must create the files manually on the USB flash drive. Use table Table 4 on page 14 to determine the appropriate addresses for the table below.

The table examples are from the table in “Information required before initializing your system” on page 12.

Table 20. Create two files and enter one line each, adjusted to the values fitting to your environment.

Filename	Content
satask.txt	<pre>satask mknascluster -clusterip 123.123.123.20 -mask 255.255.248.0 -gw 123.123.123.1 -consoleip 123.123.123.10</pre> <p>Where:</p> <ul style="list-style-type: none"> • clusterip = primary IP address for the Storwize V7000 system (the block system cluster) • mask = subnet mask • gw = gateway IP address for this subnet • consoleip = management IP address
cfgtask.txt	<pre>cfginit --ip=123.123.123.10 --netmask=255.255.248.0 --gateway=123.123.123.1 --serviceip1=123.123.123.11 --serviceip2=123.123.123.12 --internalips=10.254.8.1 --storwizeip=123.123.123.20</pre> <p>Where:</p> <ul style="list-style-type: none"> • ip = management IP address • netmask = subnet mask • gateway =gateway IP address • serviceip1 = file module 1 IP address • serviceip2 = file module 2 IP address • internalips = start of the internal IP address range • storwizeip = primary IP address for the Storwize V7000 system

Step 16. Initialize the Storwize V7000

This topic guides you through initializing the enclosures.

About this task

Initialize the Storwize V7000 enclosures.

Procedure

- Make sure the Storwize V7000 control enclosure has completed booting. You can verify this by checking that the power LED is solid green and the status LED is blinking green on each of the node canisters.
- Insert the USB flash drive into either USB connector (located at the back of the Storwize V7000 control enclosure) on the upper canister (node 1). While the

clustered system is being created, the amber fault LED, on the node canister blinks (the middle light, at the rear of the unit designated by the !).

3. When the amber fault LED stops blinking, proceed to “Step 17. Initializing the file modules.”

Step 17. Initializing the file modules

You must initialize your file modules before using them for the first time.

Procedure

As soon as you remove the USB flash drive from the control enclosure as instructed by the InitTool.exe tool, perform the following procedure:

1. Make sure that the blue identify indicator on each file module is blinking.
2. Insert the USB flash drive into the upper file module so that it becomes node 1. The configuration files that the control enclosure and the initialization tool put onto the upper file module set up the management communication paths in the Storwize V7000 Unified system.
3. Wait for the blue identify indicator on each file module to go out or to start blinking again. This should only take a few minutes, but it might take more than one hour if the Storwize V7000 Unified software level is older than 1.3.2.
4. Insert the USB flash drive into a Windows PC and run the initialization tool executable program that is on the USB flash drive.
5. If this part of the initial setup of the system completes successfully, the initialization tool provides a link to the management GUI where you can view the progress to completion of the initial setup task.
6. If there was a problem with this part of the initial setup, the initialization tool provides the error code and links you to the Information Center page that helps you troubleshoot the problem.
7. If the initial setup does not complete successfully, the management GUI provides the error code and links you to the Information Center page that helps you to troubleshoot the problem.

Chapter 4. Configuring the system

Set up your system for the first time.

About this task

Setting up your system for the first time:

Before you begin, make sure your system is properly cabled for the Storwize V7000 Unified system and any expansion enclosures. Refer to the cabling sections listed under Chapter 2, “Performing the hardware installation,” on page 29. The following guides you through setting up your system for the first time. The process includes the following key steps:

- Initialize the Storwize V7000
- Initialize the file modules
- Configure the software
- Check the Storwize V7000 Unified system status
- Upgrade the Storwize V7000 Unified software
- Problems with initial configuration
- Enable IBM Tivoli Assist On-Site (AOS)

Step 18. Configuring the system using the management GUI

Use the management GUI to configure your system.

About this task

Use the management GUI to configure your Storwize V7000 Unified system

What to do next

Note: For each window, complete the required information, then select **Next**, verify that there is a green check mark when the task results are presented, and select **Close**. If there is an error select the **Details** drop-down arrow and determine the issue.

1. Accept the license agreement.
2. Complete the system attributes as required. Refer to Table 5 on page 17. Select **Next**.
3. At the **System License** window, leave the values at **0** if you are not using this feature. For more information about external virtualization go to www.ibm.com/storage/support/storwize/v7000. In the **Search support** box enter **external virtualization**.
4. If you want to set up support notifications now, select **Configure Support Notifications Now**, if not, select **Next**.
 - a. If you select **Configure Support Notifications Now** then complete all the information as prompted, such as **Email server IP address**, then move to the next window.
 - b. Choose if you want to enable a proxy server from the **Configure Support Notifications** window, then select **Finish**.

5. If multiple entries from the **Domain Name Service (DNS)** are needed, enter one address then hit the + (plus) to add more.
6. Select **Edit** to indicate how the system authenticates users. Use table Table 9 on page 22 to work through the authentication strategy outlined in the tables.
7. Review the hardware image and verify that it reflects your configuration. Refer to the onscreen instructions and take the recommended actions if necessary.

Note: Depending on your server placement in the frame, the rack locations may not match.

8. It is recommended that you select **yes** to automatically configure the storage. You can choose to skip this step by selecting **Next** and configure the storage using the GUI at a later time.

Note: You have to configure the storage before using the system.

9. At the Public Networks window select the **New Network** button to add one or more public network addresses. Refer to Table 5 on page 17 for information to set up the public network information.
 - The Subnet is entered as the subnet address followed by the CIDR equivalent of the subnet mask (for example 9.11.100.100/32).
 - The Interface drop down menu specifies the network interface (for example, ethX1) to use for attaching the network. It is important to make a selection. If you leave the selection as **Not Attached** you are unable to attach new public addresses to the network
10. Select **OK**, then **Finish**, then **Close** to complete the process. The file modules reboot. Allow 15 minutes for the system to come back up before continuing.

Schedule a periodic backup of the TDB:

The Trivial DataBase (TDB) is used to store various types of information used to manage the system. It is recommended that you set up a periodic backup of the TDB, so backups are available to support personnel, in the event a TDB becomes lost or corrupted.

1. ssh to the file module management IP address (refer to Table 4 on page 14). Log in with user ID **admin** and password **admin**.
2. Type **mktask BackupTDB --minute 0 --hour 2 --dayOfWeek "*" "**

Note: If you are prompted with following message, the management service is probably not up from the reboot. Wait a few minutes and try again:

```
IBM SONAS management service is stopped
EFSSG0026I Cannot execute commands because Management Service is stopped.
Use startmgtsrv to restart the service
```

The previous command schedules a backup of the Trivial DataBase at 2:00 a.m. every day. If you want to schedule the backup at a different time, change the number following the hour parameter. The 2 in the command can range from 0 (midnight) to 23 (11 p.m.).

3. Press **Enter**.
4. Exit the ssh session.

Step 19. Change default passwords

Use the ssh connection to set the superuser, root, and admin passwords.

About this task

For best security practices, it is always recommended that you change the default passwords for the superuser, root, and admin passwords. Make sure you record the new passwords in a secure location.

Note: A good password should be at least eight characters in length and contain a mix of uppercase letters, lowercase letters, and numbers.

Procedure

1. First ssh to the file module management IP address (refer to Table 5 on page 17) using port 22. Log in with user ID **admin** and password **admin**.
2. Change the default superuser password for the control enclosure. Issue command `svctask chuser -password superuser_password superuser`, where `superuser_password` is the new superuser password that you want to use. **The password must be a minimum of 6 characters.**
3. Change the default root password for the management node. Issue command `chrootpwd` and follow the prompts to change the password. **The password must be a minimum of 5 characters.**
4. Change the default admin password for the management node. Issue command `chuser admin -p new_password` where `new_password` is the new password that you want to use. **The password must be a minimum of 8 characters.**
5. Type `exit` to close the connection.

Step 20. Check the Storwize V7000 Unified system status

Check the health status of your system.

About this task

To check the health status of the system follow these procedures.

Procedure

1. Log into the management GUI, if not already logged in from the previous step.
2. Check the **Health Status** in the lower right corner of the GUI.
3. If there are any warning or errors noted, hover over the **Monitoring** icon on the left of the page and select **Events**. A listing of errors will be posted.
4. Click on the error for further analysis and details of corrective actions to take.

Step 21. Upgrade the Storwize V7000 Unified software

Upgrade the system software if necessary.

About this task

Use the management GUI to install the latest Storwize V7000 Unified software.

Procedure

Select **Settings** and then **General** from the management GUI. From the **General** menu select **Upgrade Software**. This page will help you to search for upgrades, get upgrades, and install an upgrade.

Step 22. Problems with initial configuration

This topic helps you to solve configuration problems.

About this task

If USB key is missing or faulty:

- Contact the IBM Support Center.
- Install the latest InitTool.exe (or reinstall if tool is not launching). Go to <http://www-933.ibm.com/support/fixcentral/options> and select the following options to locate the tool. The options are listed under the **Select product** tab, at the bottom of the page:
 - Product Group: **Storage Systems**
 - Product Family: **Disk Systems**
 - Product: **IBM Storwize V7000 Unified**
 - Release: **All**
 - Platform: **All**

Before loading the USB flash drive verify it has a FAT32 formatted file system. Plug the USB flash drive into the laptop. Go to Start (my computer), right-click the USB drive. The general tab next to File system should say FAT32.

- If the USB flash drive is not formatted as FAT32, format it. To format, right-click it, select format, under filesystem. Select FAT32 and then click Start. Continue as prompted.

InitTool.exe is not loaded on the USB key, or fails to launch:

- Install the latest InitTool.exe (or reinstall if tool is not launching). Go to <http://www-933.ibm.com/support/fixcentral/options> and select the following options to locate the tool. The options are listed under the **Select product** tab, at the bottom of the page:
 - Product Group: **Storage Systems**
 - Product Family: **Disk Systems**
 - Product: **IBM Storwize V7000 Unified**
 - Release: **All**
 - Platform: **All**

Amber LED on node canister does not stop flashing during install:

Allow at least 15 minutes for the LED to stop flashing. If flashing continues beyond 15 minutes, remove the USB flash drive and insert in your laptop. Navigate to the `satask_results.html` file and scan for errors and follow the service action recommendation. Take that action and retry installation.

An error is posted in the `satask_results.html`:

Take the recommended action, reboot the node, and restart the procedure.

Amber LED on node canister does not stop flashing during install:

Allow at least 15 minutes for the LED to stop flashing. If flashing continues beyond 15 minutes, remove the USB flash drive and insert in your laptop.

Navigate to the `satask_results.html` file and scan for errors and follow the service action recommendation. Take that action and retry installation.

An error is posted in the `satask_results.html`:

Take the recommended service action given by **`sainfo lsservicerecommendation`** in the `satask_results.html` file, reboot the node, and restart the initial setup procedure.

If `satask_results.html` contains node error code 835 or node error code 550 then this can indicate that the node canisters were not able to communicate with each other at some time during the creation of the block cluster. This can occur because the PCIe link between the node canisters is temporarily broken when the nodes are restarted, as part of the create cluster process. This can generate node error codes 835 and 550. These are transitional errors that can be ignored if the nodes are now in active state with no errors. Follow this procedure to check that the errors are gone, using the USB flash drive:

- Save a copy of `satask.txt` and `satask_results.html`.
- Make sure that there is no `satask.txt` file on the USB flash drive before you plug it into the control enclosure. Plug the USB flash drive into the control enclosure. The orange fault light should go on for a short time only (such as a slow blink for a few seconds). Wait for the orange fault light to go out then unplug the USB flash drive and plug it into another computer so that you can look at the contents of the `satask_results.html` file on the USB flash drive. The `satask_results.html` will contain the output from a number of `sainfo` commands.
- Check the following:
 - The `cluster_status` under **`sainfo lsservicenodes`** should be Active.
 - The `node_status` should be Active for both node canisters in the cluster under **`sainfo lsservicenodes`**. Otherwise, follow the service action under `sainfo lsservicerecommendation`.
 - There should be nothing in the `error_data` column against each node under `sainfo lsservicenodes`. Otherwise, follow the service action under **`sainfo lsservicerecommendation`**.

This is an example of what the `satask_results.html` can contain on a healthy storage system, with which you can compare your results:

Service Command Results

Thu Apr 19 08:23:42 UTC 2012
satask.txt file not found.

System Status

sainfo lsservicenodes

panel_name	cluster_id	cluster_name	node_id	node_name	relation	node_status
error_data						
01-1	00000200A4E008BA	Cluster_9.71.18.184	1	node1	local	Active
01-2	00000200A4E008BA	Cluster_9.71.18.184	2	node2	partner	Active

sainfo lsservicestatus

panel_name 01-1
cluster_id 00000200a4e008ba
cluster_name Cluster_9.71.18.184
cluster_status Active
cluster_ip_count 2
cluster_port 1
cluster_ip 9.71.18.184
cluster_gw 9.71.18.1
cluster_mask 255.255.255.0

...
...

sainfo lsservicerecommendation

service_action
No service action required, use console to manage node.

Blue LED on file module, where the USB key was inserted, keeps flashing (does not turn solid as stated in the instructions):

- Allow 5 minutes at least, remove the USB flash drive, insert it into your laptop. Verify that the InitTool set up information is correct, navigate to the SONAS_results.txt file, and open it. Check for errors and corrective actions. Refer to *Storwize V7000 Unified Problem Determination Guide* PDF on the CD.
- If no errors are listed, reboot the server (allow server to start), reinsert the USB flash drive, and try again.

Blue LED on the other file module (without USB key) keeps flashing (does not turn solid or off as listed in instructions):

Wait for the primary file module to start flashing, remove the USB flash drive, insert it into you laptop, verify the InitTool set up information is correct , navigate to the SONAS_results.txt file and open it. Check for errors and corrective actions (refer to *Storwize V7000 Unified Problem Determination Guide* PDF on the CD). If no errors are listed, reboot both file modules, allow file modules to boot completely, reinsert the USB flash drive as originally instructed and try again.

Installed with the incorrect control enclosure or file module IP addresses:

If it is determined that the addresses were entered incorrectly, they can be changed at the command line as user **admin** with the following commands:

- For control enclosure IP changes use: **svctask chsystemip**
- For file module management node changes use: **chnwmgt**

Refer to the man pages for usage.

Step 23. Enable IBM Tivoli Assist On-Site (AOS)

IBM Tivoli Assist On-Site (AOS) is a lightweight remote support program intended primarily for help desks and support engineers to diagnose and fix problems without the need of any external dependencies. Assist On-Site is based on the IBM Tivoli Remote Control technology.

About this task

Assist On-Site has been developed specifically to meet functionality, security, and privacy requirements of IBM and IBM customers. Support engineers and their customers can run it on various platforms. It currently has a native version for the 32 bit Windows environment and generic Linux compatible operating systems. Assist On-Site uses IBM AES MARS encryption, NTLM authentication, and IBM intranet authentication for IBM support engineers. Assist On-Site can also support lightweight Rational® Host Access Transformation Services emulator sessions for computers running z/OS® and Power i.

Assist On-Site provides a launch-in-context feature such that support engineers can start Assist On-Site from within the session of the third-party support tool. For restricted use only, Assist On-Site supports IBM diagnostic tools to function over the Assist On-Site connection for the purpose of debugging hardware devices and IBM software.

The AOS feature is disabled by default. To enable it, do the following:

1. From the Storwize V7000 Unified GUI, select **Support**, under **Setting** icon.
2. Click the **AOS** tab.
3. Click the **Edit** button at the bottom.
4. Click **Enable Assist on Site (AOS)**
5. Select either **Lights On** or **Lights Out**. For Storwize V7000 Unified it is recommend to select **Lights Out**. **Lights On** establishes a connection through the local console of the system and thus requires the specific file module to have a keyboard, mouse, and monitor attached for local access and connectivity. **Lights Out** allows for remote support connection to be accepted automatically by the system.
6. Enter any proxy settings if required for AOS.

Note: Establishment of an AOS connection requires access to ports 80, 443, and 8200. The AOS connection provides the ability to make direct outgoing TCP connections, availability of a SOCKS server, or an HTTP proxy.

7. Click on **OK** to complete this procedure.

Step 24. Registering for My Notification

IBM periodically issues updates to products, which help improve overall quality and reliability, through My Notifications.

About this task

Register for My Notifications to establish quick links to important information and to receive daily or weekly notifications of the following product specific information:

- Downloads and drivers
- Flashes

- Forums/discussion groups
- Problem solving information
- Product information and publications

Procedure

To register for My Notifications:

1. Establish an IBM ID and password at <https://www.ibm.com/account/myibm/profile.do?cc=us&lc=en&page=reg>.
2. Then go to <https://www.ibm.com/support/mynotifications> to set up your notification preferences.

Step 25. Next steps

After you have completed the initialization and initial configuration of your system here are some pointers to the next configuration steps.

Pointers to the configuration tasks that you may want to do next

- If you wish to change the bonding of the public network ports on the file modules, for example to change the bond mode to 4. It is best to do this before defining the public IP addresses, so that you do not have to detach and reattach the Public networks (ethX0 and ethX1). Thus, client computers will not lose access to files because access has not, yet, been configured. In addition, it is also convenient to enable jumbo frames at the same time. Refer to Changing a bond network interface on a file module, located in the Information Center, for information on changing network bonding.
- If you have additional control enclosures to add to the system refer to Installing additional control enclosures, located in the Information Center.
- If you have connected the second 1 Gbps Ethernet port on each node canister in each control enclosure to your network then you can configure it with the secondary system IP address to give a redundant path for the active management node running on a file module to ssh block storage CLI commands to the main configuration node running on one of the node canisters in one of the control enclosures. Refer to Ethernet connectivity from file modules to the control enclosure, located in the Information Center, for examples of using the **chsystemip** and **chstoragesystem** CLI commands.
- Investigate the Suggested tasks by selecting the **Suggested Tasks** button in the **Home > Overview** panel of the management GUI. For example you can set up the service IP addresses for the node canisters in the control enclosures and you can set up event notifications if you skipped that during initial configuration.
- For other configuration tasks refer to the Configuring section of the Information Center.

Appendix. Accessibility features for *IBM Storwize V7000 Unified*

Accessibility features help a user who has a physical disability, such as restricted mobility or limited vision, to use software products successfully.

Accessibility features

These are the major accessibility features associated with the *Storwize V7000 Unified Information Center*:

- You can use screen-reader software and a digital speech synthesizer to hear what is displayed on the screen. PDF documents have been tested using Adobe Reader version 7.0. HTML documents have been tested using JAWS version 13.0.
- This product uses standard Windows navigation keys.

Keyboard navigation

You can use keys or key combinations to perform operations and initiate menu actions that can also be done through mouse actions. You can navigate the *Storwize V7000 Unified Information Center* from the keyboard by using the shortcut keys for your browser or screen-reader software. See your browser or screen-reader software Help for a list of shortcut keys that it supports.

IBM and accessibility

See the IBM Human Ability and Accessibility Center for more information about the commitment that IBM has to accessibility.

Notices

This information was developed for products and services offered in the U.S.A.

IBM may not offer the products, services, or features discussed in this document in other countries. Consult your local IBM representative for information on the products and services currently available in your area. Any reference to an IBM product, program, or service is not intended to state or imply that only that IBM product, program, or service may be used. Any functionally equivalent product, program, or service that does not infringe any IBM intellectual property right may be used instead. However, it is the user's responsibility to evaluate and verify the operation of any non-IBM product, program, or service.

IBM may have patents or pending patent applications covering subject matter described in this document. The furnishing of this document does not grant you any license to these patents. You can send license inquiries, in writing, to:

*IBM Director of Licensing
IBM Corporation
North Castle Drive
Armonk, NY 10504-1785
U.S.A.*

For license inquiries regarding double-byte character set (DBCS) information, contact the IBM Intellectual Property Department in your country or send inquiries, in writing, to:

*Intellectual Property Licensing
Legal and Intellectual Property Law
IBM Japan Ltd.
19-21, Nihonbashi-Hakozakicho, Chuo-ku
Tokyo 103-8510, Japan*

The following paragraph does not apply to the United Kingdom or any other country where such provisions are inconsistent with local law:

INTERNATIONAL BUSINESS MACHINES CORPORATION PROVIDES THIS PUBLICATION "AS IS" WITHOUT WARRANTY OF ANY KIND, EITHER EXPRESS OR IMPLIED, INCLUDING, BUT NOT LIMITED TO, THE IMPLIED WARRANTIES OF NON-INFRINGEMENT, MERCHANTABILITY OR FITNESS FOR A PARTICULAR PURPOSE. Some states do not allow disclaimer of express or implied warranties in certain transactions, therefore, this statement may not apply to you.

This information could include technical inaccuracies or typographical errors. Changes are periodically made to the information herein; these changes will be incorporated in new editions of the publication. IBM may make improvements and/or changes in the product(s) and/or the program(s) described in this publication at any time without notice.

Any references in this information to non-IBM Web sites are provided for convenience only and do not in any manner serve as an endorsement of those Web sites. The materials at those Web sites are not part of the materials for this IBM product and use of those Web sites is at your own risk.

IBM may use or distribute any of the information you supply in any way it believes appropriate without incurring any obligation to you.

Licensees of this program who wish to have information about it for the purpose of enabling: (i) the exchange of information between independently created programs and other programs (including this one) and (ii) the mutual use of the information which has been exchanged, should contact:

*IBM Corporation
Almaden Research
650 Harry Road
Bldg 80, D3-304, Department 277
San Jose, CA 95120-6099
U.S.A.*

Such information may be available, subject to appropriate terms and conditions, including in some cases, payment of a fee.

The licensed program described in this document and all licensed material available for it are provided by IBM under terms of the IBM Customer Agreement, IBM International Program License Agreement or any equivalent agreement between us.

Any performance data contained herein was determined in a controlled environment. Therefore, the results obtained in other operating environments may vary significantly. Some measurements may have been made on development-level systems and there is no guarantee that these measurements will be the same on generally available systems. Furthermore, some measurements may have been estimated through extrapolation. Actual results may vary. Users of this document should verify the applicable data for their specific environment.

Information concerning non-IBM products was obtained from the suppliers of those products, their published announcements or other publicly available sources. IBM has not tested those products and cannot confirm the accuracy of performance, compatibility or any other claims related to non-IBM products. Questions on the capabilities of non-IBM products should be addressed to the suppliers of those products.

All statements regarding IBM's future direction or intent are subject to change or withdrawal without notice, and represent goals and objectives only.

This information is for planning purposes only. The information herein is subject to change before the products described become available.

This information contains examples of data and reports used in daily business operations. To illustrate them as completely as possible, the examples include the names of individuals, companies, brands, and products. All of these names are fictitious and any similarity to the names and addresses used by an actual business enterprise is entirely coincidental.

COPYRIGHT LICENSE:

This information contains sample application programs in source language, which illustrate programming techniques on various operating platforms. You may copy, modify, and distribute these sample programs in any form without payment to IBM, for the purposes of developing, using, marketing or distributing application

programs conforming to the application programming interface for the operating platform for which the sample programs are written. These examples have not been thoroughly tested under all conditions. IBM, therefore, cannot guarantee or imply reliability, serviceability, or function of these programs. The sample programs are provided "AS IS", without warranty of any kind. IBM shall not be liable for any damages arising out of your use of the sample programs.

If you are viewing this information softcopy, the photographs and color illustrations may not appear.

Trademarks

IBM trademarks and special non-IBM trademarks in this information are identified and attributed.

IBM, the IBM logo, and ibm.com[®] are trademarks or registered trademarks of International Business Machines Corp., registered in many jurisdictions worldwide. Other product and service names might be trademarks of IBM or other companies. A current list of IBM trademarks is available on the web at Copyright and trademark information at www.ibm.com/legal/copytrade.shtml.

Adobe and the Adobe logo are either registered trademarks or trademarks of Adobe Systems Incorporated in the United States, and/or other countries.

Intel, Intel logo, Intel Xeon, and Pentium are trademarks or registered trademarks of Intel Corporation or its subsidiaries in the United States and other countries.

Linux is a registered trademark of Linus Torvalds in the United States, other countries, or both.

Microsoft, Windows, Windows NT, and the Windows logo are trademarks of Microsoft Corporation in the United States, other countries, or both.

UNIX is a registered trademark of The Open Group in the United States and other countries.

Java and all Java-based trademarks and logos are trademarks or registered trademarks of Oracle and/or its affiliates.

Electronic emission notices

The following electronic emission statements apply to this product. The statements for other products that are intended for use with this product are included in their accompanying documentation.

Federal Communications Commission (FCC) statement

This explains the Federal Communications Commission's (FCC) statement.

This equipment has been tested and found to comply with the limits for a Class A digital device, pursuant to Part 15 of the FCC Rules. These limits are designed to provide reasonable protection against harmful interference when the equipment is operated in a commercial environment. This equipment generates, uses, and can radiate radio frequency energy and, if not installed and used in accordance with the instruction manual, might cause harmful interference to radio communications.

Operation of this equipment in a residential area is likely to cause harmful interference, in which case the user will be required to correct the interference at his own expense.

Properly shielded and grounded cables and connectors must be used in order to meet FCC emission limits. IBM is not responsible for any radio or television interference caused by using other than recommended cables and connectors, or by unauthorized changes or modifications to this equipment. Unauthorized changes or modifications could void the user's authority to operate the equipment.

This device complies with Part 15 of the FCC Rules. Operation is subject to the following two conditions: (1) this device might not cause harmful interference, and (2) this device must accept any interference received, including interference that might cause undesired operation.

Industry Canada compliance statement

This Class A digital apparatus complies with ICES-003.

Cet appareil numérique de la classe A est conform à la norme NMB-003 du Canada.

Avis de conformité à la réglementation d'Industrie Canada

Cet appareil numérique de la classe A est conforme à la norme NMB-003 du Canada.

Australia and New Zealand Class A Statement

Attention: This is a Class A product. In a domestic environment this product might cause radio interference in which case the user might be required to take adequate measures.

European Union Electromagnetic Compatibility Directive

This product is in conformity with the protection requirements of European Union (EU) Council Directive 2004/108/EC on the approximation of the laws of the Member States relating to electromagnetic compatibility. IBM cannot accept responsibility for any failure to satisfy the protection requirements resulting from a non-recommended modification of the product, including the fitting of non-IBM option cards.

Attention: This is an EN 55022 Class A product. In a domestic environment this product might cause radio interference in which case the user might be required to take adequate measures.

Responsible Manufacturer:

International Business Machines Corp.
New Orchard Road
Armonk, New York 10504
914-499-1900

European community contact:

IBM Deutschland GmbH
Technical Regulations, Department M372
IBM-Allee 1, 71139 Ehningen, Germany
Tele: +49 7032 15 2941
e-mail: mailto:lugi@de.ibm.com

Germany Electromagnetic compatibility directive

Deutschsprachiger EU Hinweis: Hinweis für Geräte der Klasse A EU-Richtlinie zur Elektromagnetischen Verträglichkeit

Dieses Produkt entspricht den Schutzanforderungen der EU-Richtlinie 2004/108/EG zur Angleichung der Rechtsvorschriften über die elektromagnetische Verträglichkeit in den EU-Mitgliedsstaaten und hält die Grenzwerte der EN 55022 Klasse A ein.

Um dieses sicherzustellen, sind die Geräte wie in den Handbüchern beschrieben zu installieren und zu betreiben. Des Weiteren dürfen auch nur von der IBM empfohlene Kabel angeschlossen werden. IBM übernimmt keine Verantwortung für die Einhaltung der Schutzanforderungen, wenn das Produkt ohne Zustimmung der IBM verändert bzw. wenn Erweiterungskomponenten von Fremdherstellern ohne Empfehlung der IBM gesteckt/eingebaut werden.

EN 55022 Klasse A Geräte müssen mit folgendem Warnhinweis versehen werden:

"Warnung: Dieses ist eine Einrichtung der Klasse A. Diese Einrichtung kann im Wohnbereich Funk-Störungen verursachen; in diesem Fall kann vom Betreiber verlangt werden, angemessene Maßnahmen zu ergreifen und dafür aufzukommen."

Deutschland: Einhaltung des Gesetzes über die elektromagnetische Verträglichkeit von Geräten

Dieses Produkt entspricht dem "Gesetz über die elektromagnetische Verträglichkeit von Geräten (EMVG)." Dies ist die Umsetzung der EU-Richtlinie 2004/108/EG in der Bundesrepublik Deutschland.

Zulassungsbescheinigung laut dem Deutschen Gesetz über die elektromagnetische Verträglichkeit von Geräten (EMVG) (bzw. der EMC EG Richtlinie 2004/108/EG) für Geräte der Klasse A

Dieses Gerät ist berechtigt, in Übereinstimmung mit dem Deutschen EMVG das EG-Konformitätszeichen - CE - zu führen.

Verantwortlich für die Einhaltung der EMV Vorschriften ist der Hersteller:

International Business Machines Corp.
New Orchard Road
Armonk, New York 10504
Tel: 914-499-1900

Der verantwortliche Ansprechpartner des Herstellers in der EU ist:

IBM Deutschland GmbH
Technical Regulations, Department M372

IBM-Allee 1, 71139 Ehningen, Germany
Tele: +49 7032 15 2941
e-mail: <mailto:lugi@de.ibm.com>

**Generelle Informationen: Das Gerät erfüllt die
Schutzanforderungen nach EN 55024 und EN 55022 Klasse A.**

Japan VCCI Council Class A statement

この装置は、クラス A 情報技術装置です。この装置を家庭環境で使用すると電波妨害を引き起こすことがあります。この場合には使用者が適切な対策を講ずるよう要求されることがあります。 VCCI-A

People's Republic of China Class A Electronic Emission Statement

中华人民共和国“A类”警告声明

声明

此为A级产品，在生活环境中，该产品可能会造成无线电干扰。在这种情况下，可能需要用户对其干扰采取切实可行的措施。

International Electrotechnical Commission (IEC) statement

This product has been designed and built to comply with (IEC) Standard 950.

United Kingdom telecommunications requirements

This apparatus is manufactured to the International Safety Standard EN60950 and as such is approved in the U.K. under approval number NS/G/1234/J/100003 for indirect connection to public telecommunications systems in the United Kingdom.

Korean Communications Commission (KCC) Class A Statement

이 기기는 업무용(A급)으로 전자파적합기기로서 판매자 또는 사용자는 이 점을 주의하시기 바라며, 가정외의 지역에서 사용하는 것을 목적으로 합니다.

Russia Electromagnetic Interference (EMI) Class A Statement

ВНИМАНИЕ! Настоящее изделие относится к классу А.
В жилых помещениях оно может создавать радиопомехи, для снижения которых необходимы дополнительные меры

rusemi

Taiwan Class A compliance statement

警告使用者：
這是甲類的資訊產品，在居住的環境中使用時，可能會造成射頻干擾，在這種情況下，使用者會被要求採取某些適當的對策。

tailemi

European Contact Information

This topic contains the product service contact information for Europe.

European Community contact:
IBM Technical Regulations
Pascalstr. 100, Stuttgart, Germany 70569
Tele: 0049 (0)711 785 1176
Fax: 0049 (0)711 785 1283
Email: [mailto: tjahn @ de.ibm.com](mailto:tjahn@de.ibm.com)

Taiwan Contact Information

This topic contains the product service contact information for Taiwan.

IBM Taiwan Product Service Contact Information:
IBM Taiwan Corporation
3F, No 7, Song Ren Rd., Taipei Taiwan
Tel: 0800-016-888

台灣IBM 產品服務聯絡方式：
台灣國際商業機器股份有限公司
台北市松仁路7號3樓
電話：0800-016-888

f2c00790



Part Number: 00AR049

Printed in USA

GA32-1056-07



(1P) P/N: 00AR049

