

IBM TotalStorage SAN256B Director



# Installation, Service, and User's Guide

*Service information: 2109/M48*

**Read Before Using**

This product contains software that is licensed under written license agreements. Your use of such software is subject to the license agreements under which they are provided.



IBM TotalStorage SAN256B Director



# Installation, Service, and User's Guide

*Service information: 2109/M48*

**Note:**

Before using this information and the product it supports, read the information in “Notices” on page 123.

**First Edition (August 2005)**

The following paragraph does not apply to any country (or region) where such provisions are inconsistent with local law.

INTERNATIONAL BUSINESS MACHINES CORPORATION PROVIDES THIS PUBLICATION “AS IS” WITHOUT WARRANTY OF ANY KIND, EITHER EXPRESS OR IMPLIED, INCLUDING, BUT NOT LIMITED TO, THE IMPLIED WARRANTIES OF MERCHANTABILITY OR FITNESS FOR A PARTICULAR PURPOSE. Some states (or regions) do not allow disclaimer of express or implied warranties in certain transactions; therefore, this statement may not apply to you.

Order publications through your IBM representative or the IBM branch office serving your locality.

© Copyright International Business Machines Corporation 2005. All rights reserved.

US Government Users Restricted Rights – Use, duplication or disclosure restricted by GSA ADP Schedule Contract with IBM Corp.

---

# Contents

<b>Figures</b> . . . . .	vii
<b>Tables</b> . . . . .	ix
<b>Safety and environmental notices</b> . . . . .	xi
Safety notices and labels . . . . .	xi
Danger notices . . . . .	xi
Caution notices . . . . .	xiv
Safety labels . . . . .	xvi
Attention notices . . . . .	xvii
Rack safety . . . . .	xviii
Rack installation . . . . .	xviii
Rack relocation (19" rack) . . . . .	xix
Safety inspections . . . . .	xx
Removing ac power . . . . .	xx
External machine checks . . . . .	xx
Internal machine checks . . . . .	xx
Environmental notices . . . . .	xx
Product recycling and disposal . . . . .	xxi
Battery return program . . . . .	xxi
Cable warning . . . . .	xxii
<b>About this document</b> . . . . .	xxiii
Who should read this document . . . . .	xxiii
Product documents . . . . .	xxiii
Brocade documents . . . . .	xxiii
IBM and Brocade product matrix . . . . .	xxiii
Getting help . . . . .	xxiv
How to send your comments . . . . .	xxv
<b>Chapter 1. Introduction</b> . . . . .	1
Overview of the SAN256B . . . . .	1
Hardware components . . . . .	2
High availability . . . . .	4
Reliability . . . . .	5
Serviceability . . . . .	5
Software features . . . . .	6
Security . . . . .	6
Network Manageability . . . . .	7
Port numbering . . . . .	7
<b>Chapter 2. Installing and removing a SAN256B director</b> . . . . .	9
Ordering the lift tool . . . . .	10
World trade locations . . . . .	10
United States locations . . . . .	10
Unpacking the director . . . . .	11
Installing an additional director in a cabinet . . . . .	13
Time required . . . . .	13
Tools required . . . . .	13
Installing the brackets . . . . .	14
Using the lift tool, the 24-inch load plate, and the bridge tool . . . . .	18
Removing a SAN256B from the cabinet . . . . .	23

<b>Chapter 3. Starting and configuring the director</b>	27
Providing initial power to the director	28
Establishing a serial connection	30
Initial configuration parameters	31
Configuring the director IP addresses	32
Establish an Ethernet connection	33
Customize a switch name	34
Set the Domain ID	34
Verifying the PID mode and connecting to the fabric	34
Enabling software licenses	35
Backing up the configuration	36
<b>Chapter 4. Monitoring system components</b>	37
Port blade status	37
CP blade status	40
Power supply status	43
Blower assembly status	44
WWN card status	46
<b>Chapter 5. Removing and installing components</b>	49
Removing and installing the chassis door	49
Time required	49
Items required	49
Removing the chassis door	49
Installing the chassis door	50
Managing cables	50
Removing and installing the cable management tray	54
Replacing the cable guides (16-port blades only)	56
Installing and removing SFPs in a port blade	57
Removing and installing a port blade or filler panel	57
Time required	59
Items required	59
Removing a port blade	59
Removing a filler panel	60
Installing a port blade	61
Installing a filler panel	63
Removing and installing a CP blade	63
Time required	64
Items required	64
Confirming a failed CP blade	64
Recording critical switch information	65
Removing a CP blade	66
Installing a CP blade	68
Verifying the operation of the new CP blade	69
Removing and installing a power supply and filler panel	71
Time required	72
Items required	72
Removing a power supply	72
Removing and installing a filler panel	74
Installing a power supply	74
Removing and installing a blower assembly	76
Time required	76
Item required	76
Removing a blower assembly	76
Installing a blower assembly	78
Replacing the WWN bezel and card	79

Time required . . . . .	80
Items required . . . . .	80
Verifying if a WWN card needs replacing . . . . .	80
Removing the WWN card . . . . .	81
Installing a WWN Card . . . . .	82
<b>Chapter 6. Replacing the chassis . . . . .</b>	<b>85</b>
Verifying necessity of replacement. . . . .	85
Preparing for a chassis replacement . . . . .	86
Time required . . . . .	86
Items required . . . . .	86
Recording critical director and SAN information . . . . .	86
Chassis critical information checklist . . . . .	89
Disconnecting the director from the network and fabric . . . . .	90
Removing components from the chassis . . . . .	90
Removing and replacing the chassis . . . . .	91
Installing components into the new chassis . . . . .	92
Reconnecting modems (optional) . . . . .	93
Verifying the correct operation of hardware . . . . .	93
Configuring the new chassis serial number . . . . .	93
Verifying the correct operation of the system . . . . .	94
Reconnecting the system to the network and fabric . . . . .	95
Verifying the correct configuration of the fabric . . . . .	96
Cable routing tables . . . . .	97
<b>Appendix A. Product specifications . . . . .</b>	<b>99</b>
System architecture . . . . .	99
Physical dimensions . . . . .	100
Facility requirements . . . . .	101
Power specifications . . . . .	101
Environmental requirements . . . . .	102
Thermal policy . . . . .	103
Data transmission ranges . . . . .	103
Fibre channel port specifications . . . . .	103
CP blade specifications . . . . .	104
Memory specifications . . . . .	104
Battery specifications . . . . .	104
Terminal serial port specifications. . . . .	104
Modem serial port specifications . . . . .	105
Power cords . . . . .	106
<b>Appendix B. Diagnostics and troubleshooting . . . . .</b>	<b>109</b>
Obtaining chassis and component status . . . . .	109
Interpreting POST and boot results . . . . .	110
POST . . . . .	110
Boot . . . . .	111
Diagnostics . . . . .	111
Troubleshooting . . . . .	112
<b>Appendix C. Setting up and installing the modems . . . . .</b>	<b>115</b>
Using high availability connectivity . . . . .	115
Connecting modems . . . . .	116
Setting up a remote modem system. . . . .	117
Verifying the modem connection . . . . .	118
<b>Appendix D. Port numbering template . . . . .</b>	<b>121</b>

<b>Notices</b> . . . . .	123
Trademarks. . . . .	125
Electronic emission notices . . . . .	125
Federal Communications Commission (FCC) Class A Statement . . . . .	125
Industry Canada Class A Emission Compliance Statement . . . . .	125
Avis de conformité à la réglementation d'Industrie Canada . . . . .	125
European Union (EU) Electromagnetic Compatibility Directive . . . . .	126
Japan VCCI Class A ITE Electronic Emission Statement . . . . .	126
Korea Class A Electronic Emission Statement . . . . .	126
 <b>Glossary</b> . . . . .	 127
 <b>Index</b> . . . . .	 141



---

## Figures

1. Port side of the SAN256B . . . . .	3
2. Blower (non-port) side of the SAN256B . . . . .	4
3. Fully populated SAN256B director with ports numbered . . . . .	8
4. SAN256B director on a pallet with packing foam removed. . . . .	12
5. Removing the chassis door . . . . .	13
6. Placement of the shelf brackets and clip nuts on the cabinet rails . . . . .	14
7. Shelf brackets are installed on the rails (cabinet walls are not shown) . . . . .	15
8. Placing the clip nuts on the rear rails (service aisle side) . . . . .	16
9. Attaching the right and left flat upper mount brackets to the chassis . . . . .	17
10. Attaching the L-shaped upper mount brackets to the rails . . . . .	17
11. Rear view of cabinet and lift tool . . . . .	19
12. Locking the shelf into position . . . . .	20
13. Attaching the mount brackets to the cabinet rails . . . . .	21
14. Attaching the port side of the chassis to the cabinet rails . . . . .	22
15. Reinstalling the chassis door . . . . .	23
16. On/Off Switch for a CP4 blade . . . . .	28
17. AC panel and power cord retainers . . . . .	29
18. FC4-16 and FC4-32 port blades . . . . .	38
19. Front of CP4 blade . . . . .	41
20. Power supply LEDs . . . . .	43
21. Blower assembly LEDs and other parts . . . . .	45
22. LEDs on the WWN card and bezel . . . . .	47
23. Upper door hinge. . . . .	50
24. Effective cable management . . . . .	52
25. Cable management tray . . . . .	53
26. Cable guides (pillars) . . . . .	53
27. Ac power connectors and ac power switches . . . . .	54
28. Cable management tray replacement . . . . .	55
29. SFP extraction tool . . . . .	57
30. Port blade removal and replacement (16-port blade shown as example) . . . . .	58
31. Removing and replacing a filler panel . . . . .	61
32. Guides inside each blade slot . . . . .	62
33. CP blade removal and replacement . . . . .	67
34. Removing and installing a power supply or filler panel . . . . .	71
35. Director ac power connectors and switches . . . . .	72
36. Power supply removal and replacement . . . . .	74
37. Blower assembly LEDs and other parts . . . . .	77
38. Blower assembly removal and installation. . . . .	78
39. WWN bezel and card removal and replacement . . . . .	79
40. Power cords . . . . .	106
41. Two modems attached for high availability . . . . .	116
42. Remote modem setup . . . . .	117
43. SAN256B port numbering template. . . . .	122



---

## Tables

1. Brocade and IBM product and model number matrix . . . . .	xxiv
2. Configuration parameters . . . . .	30
3. Example login without changing the password . . . . .	31
4. Example screen, verifying active CP blade . . . . .	31
5. Example of viewing enabled licenses . . . . .	35
6. Port blade LED descriptions . . . . .	39
7. CP blade LED patterns . . . . .	42
8. Power supply LED patterns . . . . .	44
9. Blower assembly LED patterns . . . . .	45
10. Data Stored on the WWN Card . . . . .	46
11. Messages That Can Indicate WWN Card Failure . . . . .	47
12. WWN bezel LED patterns . . . . .	48
13. Data Stored on the WWN Card . . . . .	81
14. WWN card related system log messages . . . . .	81
15. Critical information checklist example . . . . .	89
16. Sample cable routing table for SAN256B director (Switch Name: swDir) . . . . .	97
17. Cable routing table for SAN256B director . . . . .	98
18. System architecture . . . . .	99
19. System size and weight . . . . .	100
20. FRU weights . . . . .	100
21. Power specifications . . . . .	101
22. Environmental requirements . . . . .	102
23. Data transmission ranges by cable type and port speed . . . . .	103
24. Terminal serial port pinouts . . . . .	105
25. Terminal serial port pinouts . . . . .	105
26. Power cord part numbers by country or region . . . . .	106
27. Environmental status and maintenance commands . . . . .	110
28. Troubleshooting the director . . . . .	112
29. Configuration parameters . . . . .	118



---

## Safety and environmental notices

This section contains information about:

- “Safety notices and labels”
- “Rack safety” on page xviii
- “Safety inspections” on page xx
- “Environmental notices” on page xx

---

### Safety notices and labels

When using this product, observe the danger, caution, and attention notices contained in this guide. The notices are accompanied by symbols that represent the severity of the safety condition. The danger and caution notices are listed in numerical order based on their IDs, which are displayed in parentheses, for example (D004), at the end of each notice. Use this ID to locate the translation of these danger and caution notices in the *IBM eServer Safety Notices* (G229–9054) publication, which is on the CD-ROM that accompanies this product.

The following notices and statements are used in IBM® documents. They are listed below in order of increasing severity of potential hazards. Follow the links for more detailed descriptions and examples of the danger, caution, and attention notices in the sections that follow.

- **Note:** These notices provide important tips, guidance, or advice.
- **“Attention notices” on page xvii:** These notices indicate potential damage to programs, devices, or data.
- **“Caution notices” on page xiv:** These statements indicate situations that can be potentially hazardous to you.
- **“Danger notices”:** These statements indicate situations that can be potentially lethal or extremely hazardous to you. Safety labels are also attached directly to products to warn of these situations.
- In addition to these notices, “Safety labels” on page xvi may be attached to the product to warn of potential hazards.

### Danger notices

A danger notice calls attention to a situation that is potentially lethal or extremely hazardous to people. A lightning bolt symbol accompanies a danger notice to represent a dangerous electrical condition. Read and comply with the following danger notices before installing or servicing this device.



#### DANGER

To prevent a possible shock from touching two surfaces with different protective ground (earth), use one hand, when possible, to connect or disconnect signal cables. (D001)



**DANGER**

Overloading a branch circuit is potentially a fire hazard and a shock hazard under certain conditions. To avoid these hazards, ensure that your system electrical requirements do not exceed branch circuit protection requirements. Refer to the information that is provided with your device or the power rating label for electrical specifications. (D002)



**DANGER**

If the receptacle has a metal shell, do not touch the shell until you have completed the voltage and grounding checks. Improper wiring or grounding could place dangerous voltage on the metal shell. If any of the conditions are not as described, STOP. Ensure the improper voltage or impedance conditions are corrected before proceeding. (D003)



**DANGER**

An electrical outlet that is not correctly wired could place hazardous voltage on metal parts of the system or the devices that attach to the system. It is the responsibility of the customer to ensure that the outlet is correctly wired and grounded to prevent an electrical shock. (D004)

A comprehensive danger notice provides instructions on how to avoid shock hazards when servicing equipment. Unless instructed otherwise, follow the procedures in the following danger notice.



## DANGER

Electrical voltage and current from power, telephone, and communication cables are hazardous.

### To avoid a shock hazard:

- Do not connect or disconnect any cables or perform installation, maintenance, or reconfiguration of this product during an electrical storm.
- Connect all power cords to a properly wired and grounded electrical outlet. Ensure outlet supplies proper voltage and phase rotation according to the system rating plate.
- Connect any equipment that will be attached to this product to properly wired outlets.
- When possible, use one hand only to connect or disconnect signal cables.
- Never turn on any equipment when there is evidence of fire, water, or structural damage.
- Disconnect the attached power cords, telecommunications systems, networks, and modems before you open the device covers, unless instructed otherwise in the installation and configuration procedures.
- Connect and disconnect cables as described below when installing, moving, or opening covers on this product or attached devices.

### To Disconnect:

1. Turn everything OFF (unless instructed otherwise).
2. Remove power cords from the outlet.
3. Remove signal cables from connectors.
4. Remove all cables from devices.







### To Connect:

1. Turn everything OFF (unless instructed otherwise).
2. Attach all cables to devices.
3. Attach signal cables to connectors.
4. Attach power cords to outlet.
5. Turn device ON.

(D005)

## Caution notices

A caution notice calls attention to a situation that is potentially hazardous to people because of some existing condition. A caution notice can be accompanied by different symbols, as in the examples below:

If the symbol is...	It means....
	A hazardous electrical condition with less severity than electrical danger.
	A generally hazardous condition not represented by other safety symbols.
 >55kg (121.2 lb)	A specification of product weight that requires safe lifting practices. The weight range of the product is listed below the graphic, and the wording of the caution varies, depending on the weight of the device.
 <small>PIN 18P380-B 5.000752</small>	A potential hazard of pinching the hand or other body parts between parts.
	A hazardous condition due to moving parts nearby.
 Class I	A hazardous condition due to the use of a laser in the product. Laser symbols are always accompanied by the classification of the laser as defined by the U. S. Department of Health and Human Services (for example, Class I, Class II, and so forth).

Read and comply with the following caution notices before installing or servicing this device.



**CAUTION:**

**Energy hazard present. Shorting may result in system outage and possible physical injury. Remove all metallic jewelry before servicing. (C001)**



**CAUTION:**

**Only trained service personnel may replace this battery. The battery contains lithium. To avoid possible explosion, do not burn or charge the battery.**

*Do Not:*

- **Throw or immerse into water**
- **Heat to more than 100°C (212°F)**
- **Repair or disassemble**

**Exchange only with the IBM-approved part. Recycle or discard the battery as instructed by local regulations. In the United States, IBM has a process for the collection of this battery. For information, call 1-800-426-4333. Have the IBM part number for the battery unit available when you call. (C002)**





>55 kg (121.1 lb.)

**CAUTION:**

The weight of this part or unit is approximately 96 kg (216 lb). It takes specially-trained persons and/or a lifting device to safely lift this part or unit. (C011)



**CAUTION:**

The system contains circuit cards and/or assemblies that contain lead solder. To avoid the release of lead (Pb) into the environment, do not burn. Discard the circuit card as instructed by local regulations. (C014)



**CAUTION:**

This product is equipped with a 3-wire (two conductors and ground) power cable and plug. Use this power cable with a properly grounded electrical outlet to avoid electrical shock. (C018)



**CAUTION:**

This assembly contains mechanical moving parts. Use care when servicing this assembly. (C025)



Class I

**CAUTION:**

This product contains a Class 1M laser. Do not view directly with optical instruments. (C028)



**CAUTION:**

Servicing of this product or unit is to be performed by trained service personnel only. (C032)

## Safety labels

As an added precaution, safety labels are often installed directly on products or product components to warn of potential hazards. These can be either danger or caution notices, depending upon the level of the hazard.

The actual product safety labels may differ from these sample safety labels:



### DANGER

Hazardous voltage, current, or energy levels are present inside any component that has this label attached. (L001)

Do not service, there are no serviceable parts.



### DANGER

Rack-mounted devices are not to be used as a shelf or work space. (L002)

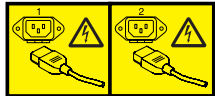

### DANGER

Multiple power cords (L003)

To remove all power to the device, disconnect all power cords.



### DANGER

High voltage present (L004)



### CAUTION:

High energy present (L005)



### CAUTION:

Hazardous moving parts nearby (L008)



SJ000752

**CAUTION:**  
**Pinch point nearby**

## Attention notices

An attention notice indicates the possibility of damage to a program, device, or system, or to data. An exclamation point symbol may accompany an attention notice, but is not required. A sample attention notice follows:

**Attention:** Do not bend a fibre cable to a radius less than 5 cm (2 in.); you can damage the cable. Tie wraps are not recommended for optical cables because they can be easily overtightened, causing damage to the cable.

---

## Rack safety

### Rack installation



#### DANGER

- Always lower the leveling pads on the rack cabinet.
- Always install stabilizer brackets on the rack cabinet.
- To avoid hazardous conditions due to uneven mechanical loading, always install the heaviest devices in the bottom of the rack cabinet. Always install servers and optional devices starting from the bottom of the rack cabinets.
- Rack-mounted devices are not to be used as a shelf or work space. Do not place any object on top of rack-mounted devices.
- Each rack cabinet might have more than one power cord. Be sure to disconnect all power cords in the rack cabinet before servicing any device in the rack cabinet.
- Connect all devices installed in a rack cabinet to power devices installed in the same rack cabinet. Do not plug a power cord from a device installed in one rack cabinet into a power device installed in a different rack cabinet.

#### CAUTION:

- Do not install a unit in a rack where the internal rack ambient temperatures will exceed the manufacturer's recommended ambient temperature for all your rack-mounted devices.
- Do not install a unit in a rack where the air flow is compromised. Ensure that air flow is not blocked or reduced on any side, front, or back of a unit used for air flow through the unit.
- Consideration should be given to the connection of the equipment to the supply circuit so that overloading of the circuits does not compromise the supply wiring or overcurrent protection.
- To provide the correct power connection to a rack, refer to the rating labels located on the equipment in the rack to determine the total power requirement of the supply circuit.
- *(For sliding drawers.)* Do not pull out or install any drawer or feature if the rack stabilizer brackets are not attached to the rack. Do not pull out more than one drawer at a time. The rack may become unstable if you pull out more than one drawer at a time.
- *(For fixed drawers.)* This drawer is a fixed drawer and should not be moved for servicing unless specified by manufacturer. Attempting to move the drawer partially or completely out of the rack may cause the rack to become unstable or cause the drawer to fall out of the rack.

(R001)

## Rack relocation (19" rack)

### CAUTION:

Removing components from the upper positions in the rack cabinet improves rack stability during relocation. Follow these general guidelines whenever you relocate a populated rack cabinet within a room or building:

- Reduce the weight of the rack cabinet by removing equipment starting at the top of the rack cabinet. When possible, restore the rack cabinet to the configuration of the rack cabinet as you received it. If this configuration is not known, you must do the following:
  - Remove all devices in the 32U position and above.
  - Ensure that the heaviest devices are installed in the bottom of the rack cabinet.
  - Ensure that there are no empty U-levels between devices installed in the rack cabinet below the 32U level.
  - If the rack cabinet you are relocating is part of a suite of rack cabinets, detach the rack cabinet from the suite.
  - Inspect the route that you plan to take when moving the rack to eliminate potential hazards.
  - Verify that the route that you choose can support the weight of the loaded rack cabinet. Refer to the documentation that came with your rack cabinet for the weight of a loaded rack cabinet.
  - Verify that all door openings are at least 760 x 2030 mm (30 x 80 in.).
  - Ensure that all devices, shelves, drawers, doors, and cables are secure.
  - Ensure that the four leveling pads are raised to their highest position.
  - Ensure that there is no stabilizer bracket installed on the rack cabinet during movement.
  - Do not use a ramp inclined at more than ten degrees.
  - Once the rack cabinet is in the new location, do the following:
    - Lower the four leveling pads.
    - Install stabilizer brackets on the rack cabinet.
    - If you removed any devices from the rack cabinet, repopulate the rack cabinet from the lowest position to the highest position.
  - If a long distance relocation is required, restore the rack cabinet to the configuration of the rack cabinet as you received it. Pack the rack cabinet in the original packaging material, or equivalent. Also, lower the leveling pads to raise the casters off of the pallet and bolt the rack cabinet to the pallet.

(R002)

---

## Safety inspections

Perform the following safety checks to identify unsafe conditions. Be cautious of potential safety hazards that are not covered in the safety checks. If unsafe conditions are present, determine how serious the hazards are and whether you should continue before you correct the problem.

### Removing ac power

Perform the following steps to remove the alternating current (ac) power:

1. Perform a controlled system shutdown.
2. Set the power switch on the product to the off position.
3. Disconnect the power cables from the power source.

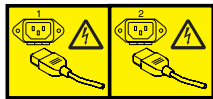

#### DANGER

Multiple power cords. (L003)

### External machine checks

Perform the following external machine checks:

1. Verify that all external covers are present and are not damaged.
2. Ensure that all latches and hinges are in correct operating condition.
3. Check the power cable for damage.
4. Check the external signal cable for damage.
5. Check the cover for sharp edges, damage, or alterations that expose the internal parts of the device.
6. Check that any unused serial ports are covered for dust and ESD protection. The cover should be kept on the serial port whenever it is not being used.
7. Correct any problems that you find.

### Internal machine checks

Perform the following internal machine checks:

1. Check for any non-IBM changes that might have been made to the machine. If any are present, obtain the “Non-IBM Alteration Attachment Survey” form, number R009, from the IBM branch office. Complete the form and return it to the branch office.
2. Check the condition of the inside of the machine for:
  - Metal or other contaminants
  - Indications of water or other fluid
  - Fire
  - Smoke damage
3. Check for any obvious mechanical problems, such as loose components.
4. Check any exposed cables and connectors for wear, cracks, or pinching.

---

## Environmental notices

Use the environmental statements and warning in this section to guide you when using this product and in properly disposing of the product and its components.

## Product recycling and disposal

This unit must be recycled or discarded according to applicable local and national regulations. IBM encourages owners of information technology (IT) equipment to responsibly recycle their equipment when it is no longer needed. IBM offers a variety of product return programs and services in several countries to assist equipment owners in recycling their IT products. Information on IBM product recycling offerings can be found on IBM's Internet site at <http://www.ibm.com/ibm/environment/products/prp.shtml>

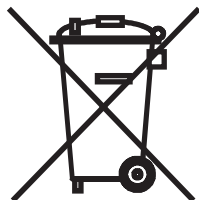

**Note:** This mark applies only to countries within the European Union (EU) and Norway.

Appliances are labeled in accordance with European Directive 2002/96/EC concerning waste electrical and electronic equipment (WEEE). The Directive determines the framework for the return and recycling of used appliances as applicable throughout the European Union. This label is applied to various products to indicate that the product is not to be thrown away, but rather reclaimed upon end of life per this Directive.

注意：このマークは EU 諸国およびノルウェーにおいてのみ適用されます。

この機器には、EU 諸国に対する廃電気電子機器指令 2002/96/EC(WEEE) のラベルが貼られています。この指令は、EU 諸国に適用する使用済み機器の回収とリサイクルの骨子を定めています。このラベルは、使用済みになった時に指令に従って適正な処理をする必要があることを知らせるために種々の製品に貼られています。

Remarque : Cette marque s'applique uniquement aux pays de l'Union Européenne et à la Norvège.

L'étiquette du système respecte la Directive européenne 2002/96/EC en matière de Déchets des Equipements Electriques et Electroniques (DEEE), qui détermine les dispositions de retour et de recyclage applicables aux systèmes utilisés à travers l'Union européenne. Conformément à la directive, ladite étiquette précise que le produit sur lequel elle est apposée ne doit pas être jeté mais être récupéré en fin de vie.

In accordance with the European WEEE Directive, electrical and electronic equipment (EEE) is to be collected separately and to be reused, recycled, or recovered at end of life. Users of EEE with the WEEE marking per Annex IV of the WEEE Directive, as shown above, must not dispose of end of life EEE as unsorted municipal waste, but use the collection framework available to customers for the return, recycling and recovery of WEEE. Customer participation is important to minimize any potential effects of EEE on the environment and human health due to the potential presence of hazardous substances in EEE. For proper collection and treatment, contact your local IBM representative.

## Battery return program

This product may contain sealed lead acid, nickel cadmium, nickel metal hydride, lithium, or lithium ion battery. Consult your user manual or service manual for specific battery information. The battery must be recycled or disposed of properly. Recycling facilities may not be available in your area. For information on disposal of

batteries outside the United States, go to <http://www.ibm.com/ibm/environment/products/batteryrecycle.shtml> or contact your local waste disposal facility.

In the United States, IBM has established a return process for reuse, recycling, or proper disposal of used IBM sealed lead acid, nickel cadmium, nickel metal hydride, and other battery packs from IBM equipment. For information on proper disposal of these batteries, contact IBM at 1-800-426-4333. Please have the IBM part number listed on the battery available prior to your call.

For Taiwan:



## Cable warning



**WARNING:** Handling the cord on this product or cords associated with accessories sold with this product, will expose you to lead, a chemical known to the State of California to cause cancer and birth defects or other reproductive harm. *Wash hands after handling.*



---

## About this document

This document describes how to install and service the IBM TotalStorage® SAN256B Director. Throughout this document, the product is referred to as the SAN256B or simply the director.

The sections that follow provide information about:

- “Who should read this document”
- “Product documents”
- “Brocade documents”
- “Getting help” on page xxiv
- “How to send your comments” on page xxv

---

## Who should read this document

This document is intended for trained service representatives who are responsible for installing and servicing the director, and for network administrators responsible for maintaining and using the director.

---

## Product documents

The following documents contain information related to this product:

- *IBM TotalStorage SAN256B Installation, Service, and User's Guide*, GC26-7761 (this document)
- *IBM eServer Safety Notices*, G229-9054
- *IBM TotalStorage SAN b-type 2109 Statement of Limited Warranty*, GC26-7743

---

## Brocade documents

IBM b-type switches use software licensed from Brocade Communications Systems, Inc. You can find information related to the software that supports the director in the following documents on the CD-ROM supplied with this product:

### **Brocade Fabric OS**

- *Brocade Fabric OS Administrator's Guide*
- *Brocade Fabric OS Command Reference Manual*
- *Brocade Fabric OS MIB Reference Manual*
- *Brocade Fabric OS System Error Message Reference Manual*

### **Brocade Fabric OS optional features**

- *Brocade Fabric Watch Administrator's Guide*
- *Brocade Secure Fabric OS User's Guide*
- *Brocade Web Tools Administrator's Guide*

## IBM and Brocade product matrix

When you use any of the Brocade documents, you will notice that the model numbers reflect the original Brocade switches. Table 1 on page xxiv provides a product matrix for you to use to correlate the Brocade model numbers to the IBM product names and machine types and model numbers. Note that a number of these products are no longer marketed by IBM or Brocade.

Table 1. Brocade and IBM product and model number matrix

Brocade product name	IBM TotalStorage product name	IBM product and model number
SilkWorm AP7420	SAN16B-R multiprotocol router	2109 Model A16
SilkWorm 200E	SAN16B-2	2005 Models B16 and 16B
SilkWorm 3250	SAN Switch H08	2005 Model H08
SilkWorm 3800	SAN Switch F16	2109 Model F16
SilkWorm 3850	SAN Switch H16	2005 Model H16
SilkWorm 3900	SAN Switch F32	2109 Model F32
SilkWorm 4100	SAN32B-2	2005 Models B32 and 32B
SilkWorm 12000	SAN Switch M12	2109 Model M12
SilkWorm 24000	SAN Switch M14	2109 Model M14
SilkWorm 48000	SAN256B Director	2109 Model M48

---

## Getting help

For the latest version of your product documentation, visit the web at <http://www.elink.ibm.link.ibm.com/public/applications/publications/cgibin/pbi.cgi>.

For more information about IBM SAN products, see the following Web site: <http://www.ibm.com/servers/storage/san/>

For support information for this product and other SAN products, see the following Web site: <http://www.ibm.com/servers/storage/support/san>

For detailed information about the Fibre Channel standards, see the Fibre Channel Industry Association (FCIA) Web site at: [www.fibrechannel.org/](http://www.fibrechannel.org/)

Visit [www.ibm.com/contact](http://www.ibm.com/contact) for the contact information for your country or region.

You can also contact IBM within the United States at 1-800-IBMSERV (1-800-426-7378). For support outside the United States, you can find the service number at: <http://www.ibm.com/planetwide/>.

---

## How to send your comments

Your feedback is important in helping us provide the most accurate and high-quality information. If you have comments or suggestions for improving this document, send us your comments by e-mail to [starpubs@us.ibm.com](mailto:starpubs@us.ibm.com) or use the Readers' Comments form at the back of this publication. Be sure to include the following:

- Exact publication title
- Form number (for example, GC26-1234-02)
- Page numbers to which you are referring

If the Reader Comment Form in the back of this manual is missing, you can direct your mail to:

International Business Machines Corporation  
Information Development  
Department GZW  
9000 South Rita Road  
Tucson, Arizona 85744-0001 U.S.A.

When you send information to IBM, you grant IBM a nonexclusive right to use or distribute the information in any way it believes appropriate without incurring any obligation to you.



---

## Chapter 1. Introduction

This chapter introduces the features and components of the IBM TotalStorage SAN256B Director. Throughout the remainder of this document, the SAN256B Director will be referred to as the SAN256B, or more commonly, as the director. This chapter contains the following information:

- “Overview of the SAN256B”
- “Hardware components” on page 2
- “High availability” on page 4
- “Reliability” on page 5
- “Serviceability” on page 5
- “Software features” on page 6

---

### Overview of the SAN256B

To meet your Storage Area Network (SAN) performance needs, the SAN256B Director is designed to deliver next generation enterprise director performance, scalability, flexibility, reliability, and availability. The director is designed to provide:

- A single domain with 256-port fabric switch functionality, yielding greater scalability with fewer domains
- Faster, dual-redundant Control Processor (CP) blades providing high availability and enabling nondisruptive software upgrades.
- Support for two new high-performance port blades running at 1-, 2-, or 4-Gbps, enabling flexible system configuration
- Redundant and hot swappable CPs, power supplies, and blower assemblies enabling a high availability platform
- Forward and backward compatibility with all IBM TotalStorage SAN Switch models
- 1-, 2-, and 4-Gbps auto-sensing capability
- Universal ports that self-configure as E\_Ports, F\_Ports, or FL\_Ports.
- Advanced Fabric Services and management tools

---

## Hardware components

Designed for mid-range to enterprise level SAN applications, the director includes a minimum of two control processors, dual power supplies, and three cooling fan assemblies, all contained in a 14U rack height. The SAN256B director base model includes the following functions:

- Full Fabric operation and Universal Port operation on all ports (F\_Port, FL\_Port, and E\_Port)
- Inter Switch Link (ISL) Trunking
- Advanced Zoning
- Web tools
- Fabric Watch
- Performance Monitor
- Hot Code Activation
- Fabric OS 5.0

The director is available with a number of options. The base configuration includes CP blades, but no port blades. Port blades are available in either 32- or 16-port configurations, with a minimum of two port blades required for host and storage connectivity. The director can be configured by adding up to eight port blades. Depending on the configuration selected, the director can contain up to 256 ports which can accommodate a mixture of both shortwave and longwave optical transceivers. Figure 1 on page 3 shows the port side of the SAN256B director with four 16-port blades, two CP blades, four 32-port blades, and two power supplies. Note that beginning with the SAN256B model, the port blades and the CP blades are labeled FC4 and CP4, respectively. The number of ports (16 or 32) are also included in the labels for the port blades. Figure 2 on page 4 shows the non-port side of the director, with three blower assemblies, and the WWN bezel.

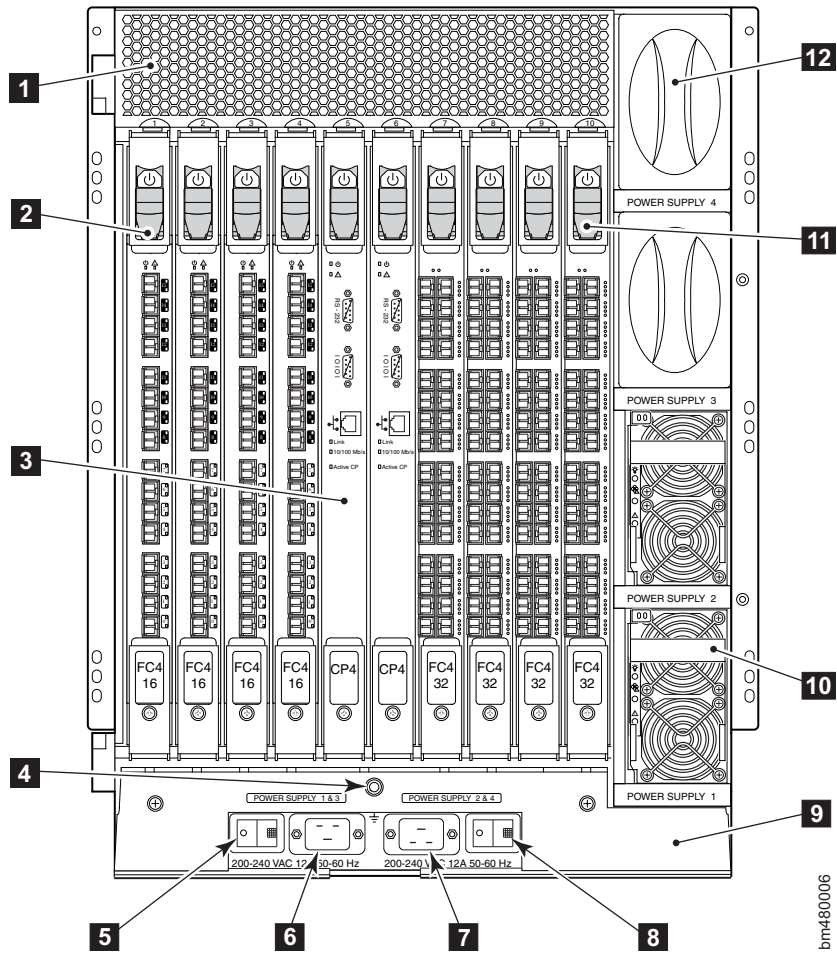

Figure 1. Port side of the SAN256B

- |  |  |
|--|--|
| <b>1</b> Exhaust vent                                    | <b>7</b> AC power switch (for power supplies 2 and 4)    |
| <b>2</b> FC4-16 port blade                               | <b>8</b> AC power connector (for power supplies 2 and 4) |
| <b>3</b> CP4 blade (control processor blade)             | <b>9</b> Cable management tray                           |
| <b>4</b> Grounding strap connector                       | <b>10</b> Power supply #1                                |
| <b>5</b> AC power switch (for power supplies 1 and 3)    | <b>11</b> FC4-32 port blade                              |
| <b>6</b> AC power connector (for power supplies 1 and 3) | <b>12</b> Power supply filler panel                      |

**Note:** Card slots are numbered 1 through 10 (left to right). Slots 1–4 and 7–10 accommodate the 16- and 32-port blades, and slots 5 and 6 accommodate the CP blades.

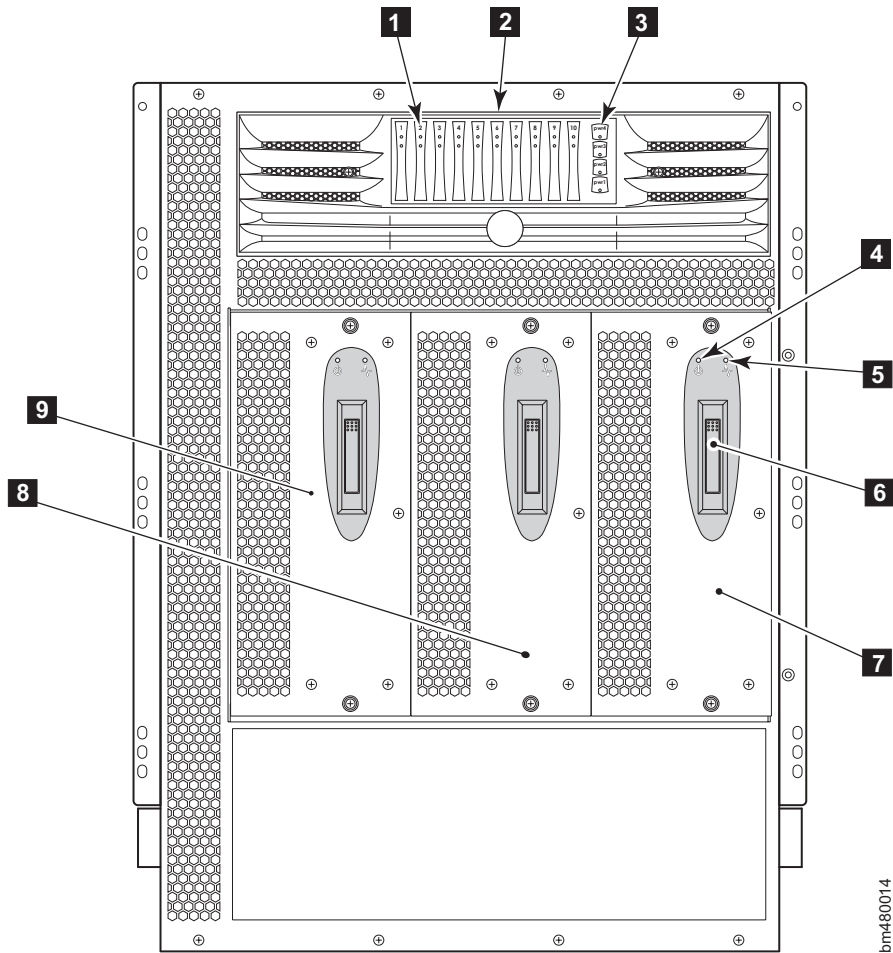

Figure 2. Blower (non-port) side of the SAN256B

- |          |                              |          |                    |
|----------|------------------------------|----------|--------------------|
| <b>1</b> | Port blade and CP blade LEDs | <b>6</b> | Blower handle      |
| <b>2</b> | WWN bezel                    | <b>7</b> | Blower assembly #3 |
| <b>3</b> | Power supply LEDs            | <b>8</b> | Blower Assembly #2 |
| <b>4</b> | Blower power LED             | <b>9</b> | Blower assembly #1 |
| <b>5</b> | Blower fault LED             |          |                    |

## High availability

The following features contribute to the director's high-availability design:

- Redundant, hot-swappable components
- Redundant power supply and blower assembly subsystems
- Enhanced data integrity on all data paths
- Fabric Shortest Path First (FSPF) rerouting around failed links
- Integration with Simple Network Management Protocol (SNMP) managers
- Automatic control processor failover
- Nondisruptive "hot" software code loads and activation



- Easy configuration, save, and restore
- Hot-swappable World Wide Name (WWN) card

The high-availability software architecture of the director provides a common framework for all applications that reside on the system, allowing global and local status to be maintained enough to manage any component failure. High-availability elements consist of the High Availability Manager, the heartbeat, the fault/health framework, the replicated database, initialization, and software upgrade.

The High Availability Manager controls access to the standby control processor, facilitates software upgrades, prevents extraneous switchover activity, closes and flushes streams as needed, provides flow control and message buffering, and supports a centralized active and standby state.

---

## Reliability

The director uses the following error detection and correction mechanisms to ensure the reliability of all data inside the chassis:

- All data inside the switch protected by the Error Detection and Correction mechanism, which checks for encoder errors and fault isolation (EDFI), such as cyclic redundancy checking (CRC), parity checking, checksum, and illegal address checking
- Power-on self test (POST)
- Dual control processors that enable hot, nondisruptive fast firmware upgrades
- Each control processor contains two serial ports and one Ethernet port. Offline control processor diagnostics and remote diagnostics simplify troubleshooting. The standby control processor continuously runs diagnostics to ensure it is operational, should a failover be necessary.
- Inter-IC (I<sup>2</sup>C) monitoring and control

---

## Serviceability

The director provides the following features to enhance and ensure serviceability:

- Modular design with hot-swappable components
- Redundant flash memory that stores two firmware images per control processor
- Extensive diagnostics and status reporting, along with a serial port to support an external, country-specific modem for remote diagnostics and status monitoring
- Nonvolatile random-access memory (NVRAM), containing the IBM serial number, Brocade serial number, revision information, and part number information
- Background health-check daemon
- Memory scrubber, self test, and bus ping to determine if a bus is not functioning
- Watchdog timers
- Status LEDs
- Predictive diagnostics analysis through Fabric Watch
- SNMP integration with higher-layer managers

---

## Software features

The SAN256B is supported by Brocade Fabric OS v5.0.1. The Fabric OS allows any Fibre Channel-compliant device to attach to the switches as long as it conforms to the device login, name service, and related Fibre Channel standards. Each operating environment requires that a Fibre Channel host bus adapter (HBA) be available with a standards-compliant driver for proper interface to the fabric.

Fabric OS consists of a set of embedded applications running on top of an embedded real-time Linux<sup>®</sup> operating system kernel. These applications are the name server, alias server, SNMP agent, and several tasks to manage address assignment, routing, link initialization, fabric initialization, link shutdown, switch shutdown, and the user interface.

Standard features include:

- **Fabric Watch**  
Monitors mission-critical fabric parameters, and provides automatic alerts to administrators of potential problems.
- **Web Tools**  
Administers, configures, and maintains fabric switches and SANs.
- **Advanced Zoning**  
Segments a fabric into virtual private SANs.
- **ISL Trunking**  
Allows up to four ISLs between the same pair of switches to be grouped and to act as a single, high-speed "pipe" or trunk with a capacity of up to 8 Gb/sec. In-order delivery of frames is guaranteed and allows ISLs to be added to or removed from the trunking group seamlessly.
- **Performance Monitoring**  
Provides SAN performance management through an end-to-end monitoring.

Optional features include:

- **Extended Fabrics**  
Provides increased ISL buffer credits to support disaster tolerance solutions with up to 70 km distance between sites
- **Remote Switch**  
Enables IBM switches to interconnect over a wide area network (WAN) using third-party gateway solutions that support FC over IP, FC over ATM, and FC over SONET.
- **Advanced Security**  
Enables policy-based security mechanisms integrated within the Fabric Operating System.
- **FICON<sup>®</sup> operation with CUP**  
Enables IBM host-based management programs to manage FICON fabric switches in-band.

## Security

Secure Telnet access is available using Secure Shell (SSH), a network security protocol for secure remote login and other secure network services over an insecure network.

Web tools management is available through a secure browser using Secure Sockets Layer (SSL). The SSL security protocol provides data encryption, server authentication, message integrity, and optional client authentication for a TCP/IP connection. Because SSL is built into all major browsers and Web servers, installing a digital certificate turns on the SSL capabilities.

## Network Manageability

The SAN256B is managed as a single element and appears as a single element to a Network Management System (NMS). The director responds to its own IP address and appears as a separate entity to the Telnet protocol and SNMP.

All management interfaces, such as Telnet, Web Tools, the Fabric Access Layer API, and Management Server, support a "port N within blade M" naming scheme.

When SNMP devices send SNMP messages to a management console running SAN management software, the information is stored in a management information base (MIB). Fabric OS v5.0.1 supports the latest Fibre Alliance Fibre Channel Management (FCMGMT) and Storage Management Initiative (SMI) MIBs, which allow common information necessary for management software to provide information to a SAN administrator.

**Note:** Refer to the *Brocade Fabric OS MIB Reference Manual* for additional MIB information.

---

## Port numbering

The area ID is equal the port number except in the following cases, :

- When you perform a port swap operation
- When you enable Extended Edge PID mode on the director. For more information on Extended Edge PID mode, refer to the *Brocade Fabric OS Administrator's Guide*.

The director uses the following port numbering scheme:

- For the FC4-16 port blade, ports are numbered from 0 through 15 from bottom to top.
- For the FC4-32 port blade, ports are numbered from 0 through 15 from bottom to top on the left set of ports and 16 through 31 from bottom to top on the right set of ports.

Slots are numbered 1 through 10, from left to right when facing the port side of the director. Figure 3 on page 8 identifies the port numbering for a fully populated (256 ports) director.

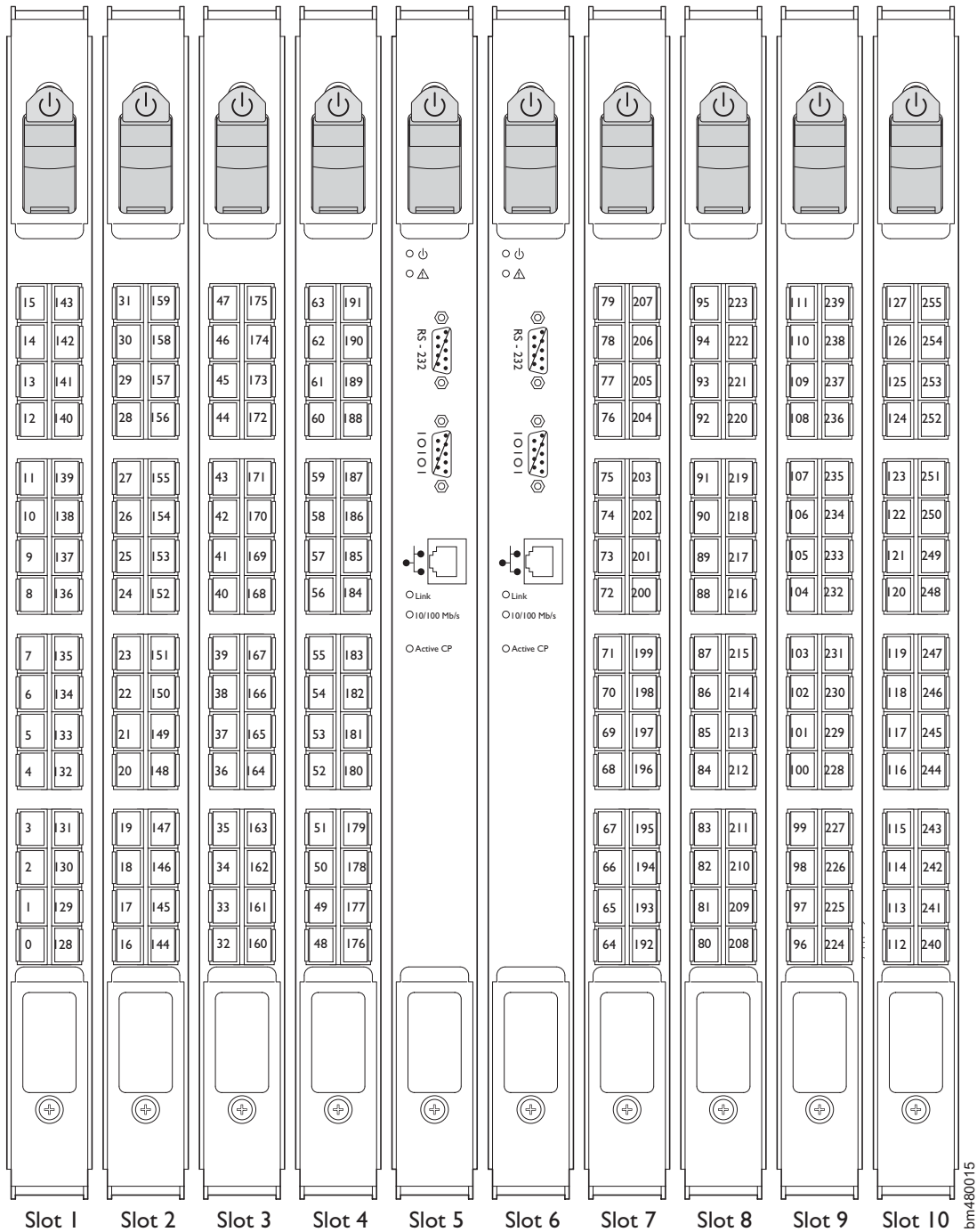

Figure 3. Fully populated SAN256B director with ports numbered

Use Appendix D, “Port numbering template,” on page 121 as a template to identify how the ports in your director are numbered with your particular configuration. If you have any 16-port blades installed, cross out the extra ports displayed on the template.

---

## Chapter 2. Installing and removing a SAN256B director

The SAN256B director is only available for installation in the IBM TotalStorage SAN Switch Cabinet C36. This director is to be installed and serviced only by qualified IBM service representatives. The SAN256B can be ordered pre-installed in the cabinet, or the director can be added to an existing C36 cabinet. The cabinet is designed to support a total of two SAN256B, M14, or M12 model directors. This chapter describes how to install the SAN256B director into a C36 cabinet, and how to remove the director from the cabinet in the event you need to move or replace the director. One director is installed in the cabinet at the factory. If the director is already installed in the cabinet, continue on to Chapter 3, “Starting and configuring the director,” on page 27.

**Attention:** Refer to “Safety and environmental notices” on page xi for general safety instructions, and “Rack safety” on page xviii before performing any installation or service procedures.



>55 kg (121.2 lb)

**CAUTION:**

**The weight of this part or unit is more than 96 kilograms (216 pounds). It takes specially trained persons with a lifting device to safely lift this part or unit. (C011)**

**CAUTION:**

**A fully populated SAN256B weighs approximately 96 kg (216 lb). Before you install it, verify that the additional weight of the chassis does not exceed the cabinet’s weight limit or unbalance the cabinet. When you calculate the additional weight, include the cards or power supplies that partially extend out of the chassis.**

Before you install a director into the cabinet, perform the following tasks:

- To ensure adequate cooling, plan to install the chassis with the port side facing the aisle where exhaust air is released (usually called the service aisle). This prevents the fans from pulling in heated exhaust air.
- Plan for managing the cables before you install the chassis. A fully populated director will have a large number of cables that must be carefully routed to minimize problems with installation and replacement of components, and in order to maintain the minimum bend radius required for optical cables. Refer to “Managing cables” on page 50 for more specific information. You can manage the cables in a variety of ways, such as:
  - Routing the cables down through the cable management tray
  - Routing the cables out either side of the chassis
  - Routing the cables through the cable channels on the sides of the cabinet
  - Using patch panels
- Ensure that the airflow in the vicinity of the director is a minimum of 595 cubic meters per hour (350 cubic feet per minute).
- Ensure that the air temperature that is measured at the blower inlet does not exceed 40°C (104°F ) during operation.

---

## Ordering the lift tool

### Important

The lift tool is required only when you install an additional director.

The ordering procedures for the lift tool vary depending on your location. You should direct questions about these procedures to your regional representative.

**Note:** The bridge tool (PN 18P5855), which is required for installation, is shipped with a new or a replacement director. The bridge tool, when installed, serves as a temporary ramp between the lift tool and the director rails that are installed in a C36 cabinet. You do not need to return the bridge tool when you are finished with it.

## World trade locations

The following ordering procedures are for world trade locations:

- Order the lift tool by using the parts order system, like any other part.
- Use the following part numbers when you order:
  - Lift tool: PN 09P2481
  - 24-inch load plate: PN 11P4369
- You do not record parts usage.
- Return the lift tool and the 24-inch load plate to the parts center after you complete the installation or removal of the director.

## United States locations

In the United States, call UPS Logistics at 800-528-6070 to order the lift tool and the 24-inch load plate.

**Note:** For the SSR branch and territory, the United States cannot order the lift tool or 24-inch load plate through the parts order system. UPS Logistics are used to ship and return the lift tool and 24-inch load plate.

Use the following part numbers when you order:

- Lift tool: PN 09P2481
- 24-inch load plate: PN 11P4369

**Note:** When you order the lift tool, you will receive an 18-inch load plate. Do not use the 18-inch load plate. You must order and use a 24-inch load plate when you install the director.

You must provide the following information when you order the lift tool. This information is necessary to ensure that the lift tool is delivered when you need it. Failure to provide this information might delay the completion of the order request and the shipping request. It might also result in a time and date to return the tool that is different from what you need.

- Phone number and customer contact
- Account code: 98577
- Time and date of delivery
- Accurate destination address with zip code

- Time and date of return pickup

You must return the lift tool at the time that was scheduled with UPS Logistics. If you need to change the scheduled return time or date, contact UPS Logistics.

You are responsible for ensuring that all of the paperwork and components are packed and restored in the arbocrate (shipping container) of the lift tool. Ensure that the lift tool is functioning properly before you release the tool to UPS Logistics for return. You are accountable for the lift tool until UPS Logistics picks up the lift tool for return delivery to their parts storage facility.

Contact your branch office tools coordinator or your region specialist if you have any questions or concerns.

---

## Unpacking the director

Complete the following steps to unpack the director.

**Note:** This procedure requires a 1/2 in. socket wrench to remove the pallet bolts.

1. Remove the upper portion of the packing crate while the switch is still in the shipping area to reduce clutter at the installation site.
  - a. Open the latches that hold the top of the crate to the pallet. To open a latch, pull the handle out, turn it to the left, then slide the latch open.
  - b. Lift the top of the crate off the pallet.
  - c. Leave the foam on top of the chassis to hold the kits in place during transportation to the installation area.
  - d. Do not move the chassis off the pallet until the door is removed.
2. Move the chassis on the pallet to the installation area, using a pallet jack or other assisted lift. Doorways must be at least 91 cm (36 in.) wide so the pallet on a pallet jack can fit through.
3. Once the pallet is in the installation location, remove the packing foam, antistatic plastic, 14U rack mount kit, and accessory kit.
4. Unscrew the four bolts that hold the director to the pallet. See Figure 4 on page 12. Remove the brackets.

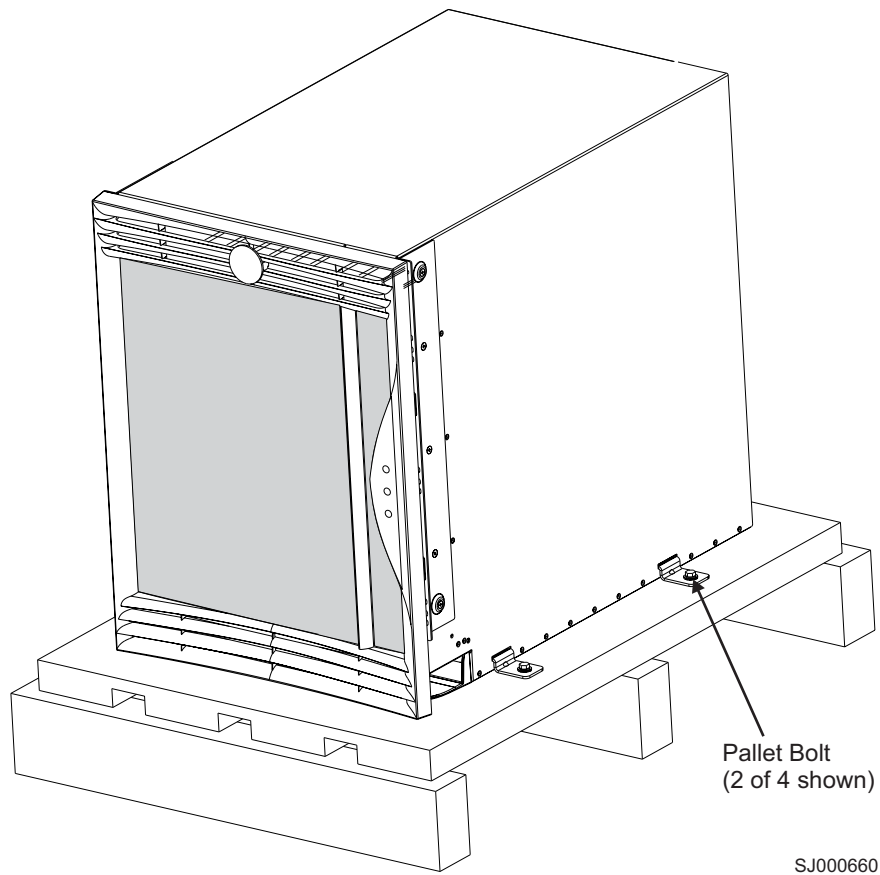

SJ000660

Figure 4. SAN256B director on a pallet with packing foam removed

**Attention:** Remove the chassis door before you move the chassis.

5. Remove the chassis door from the chassis.
  - a. Open the door 90°.
  - b. Support the door to prevent it from falling.
  - c. Push the spring-loaded pin on the upper hinge up and into the notch in the hinge. See Figure 5 on page 13.
  - d. Push the spring-loaded lever on the lower hinge down and into the notch in the hinge.
  - e. Pull the door away from the chassis.



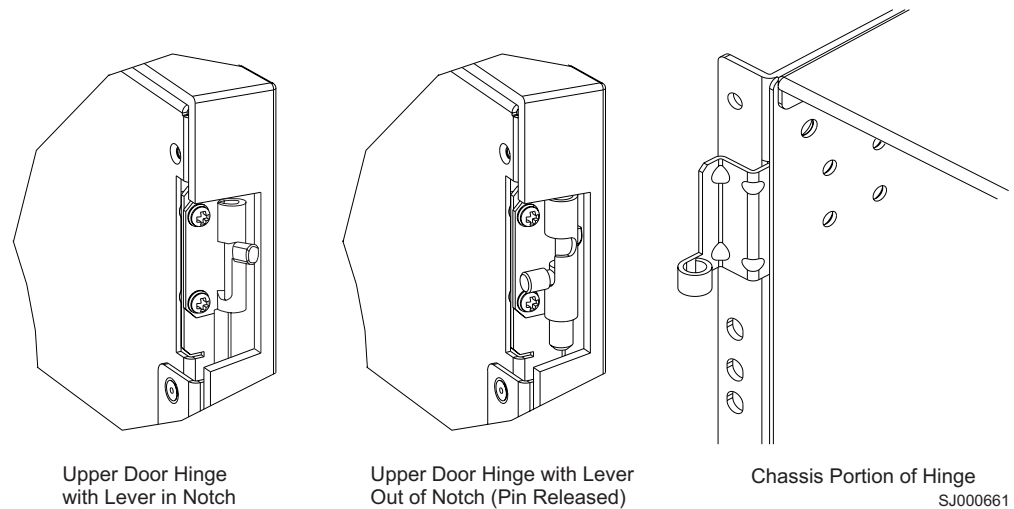

Figure 5. Removing the chassis door

---

## Installing an additional director in a cabinet

This section describes how to install the SAN256B in the Model C36 cabinet. These procedures use parts that are included in the 14U rack mount kit.

### Time required

Allow approximately 2.5 hours to complete this procedure. This includes unpacking, assembling, and repacking the lift tool. This is for the physical installation of the director only. It does not include installing Ethernet cables, SFPs, attaching and routing the fiber optic cables, or completing the initial configuration.

**Note:** Assembly instructions for the lift tool are in the shipping container.

### Tools required

You will require the following items to install the director in the cabinet:

- #2 Phillips screwdriver
- Lift tool

## Installing the brackets

Perform the following steps to install the brackets:

1. Loosen the adjusting screws on the left and right mount shelf brackets to allow for adjustment to the cabinet depth.
2. Attach the left and right mount shelf brackets to the rails in the cabinet. Standard EIA rail spacing of holes is sets of three, separated by 5/8 in., 5/8 in., and 1/2 in. See Figure 6.

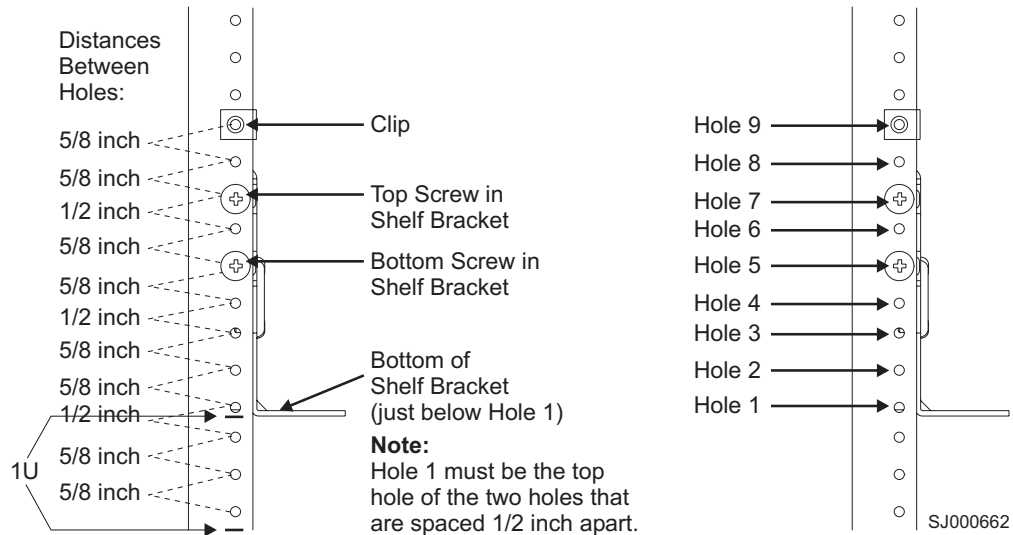
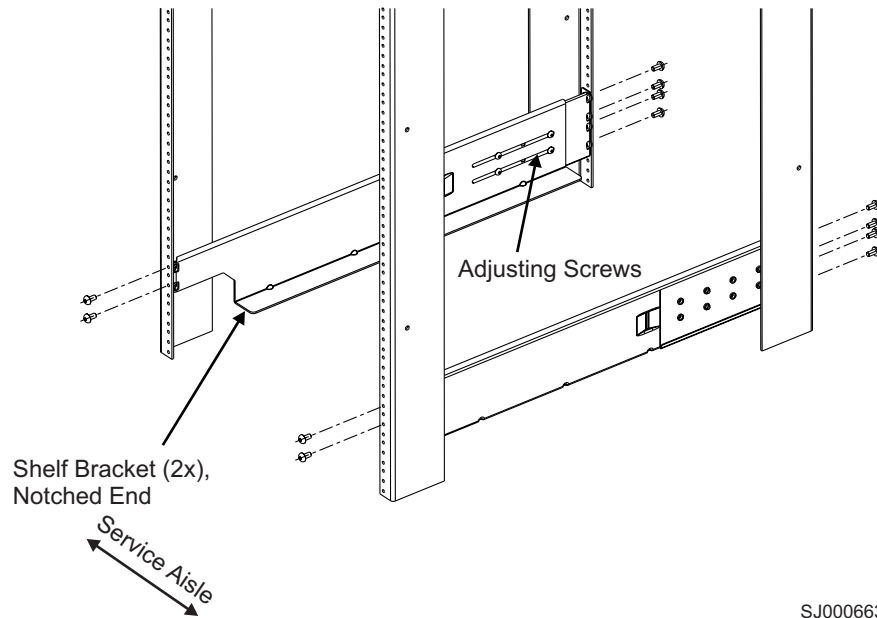

Figure 6. Placement of the shelf brackets and clip nuts on the cabinet rails

**Note:** If you are installing a SAN256B into the bottom of the rack, go to step 2a for the location of the rail. If you are installing the director into the top of the rack, go to step 2b for the location of the rail.

- a. Locate the screws in the middle of EIA unit 5 and the bottom of EIA unit 6 for the back of the cabinet. Locate the screws in the middle of EIA unit 4, the bottom of EIA unit 5, the middle of EIA unit 5, and the bottom of EIA unit 6 for the front of the cabinet.
- b. Locate the screws in the middle of EIA unit 22 and the bottom of EIA unit 23 for the back of the cabinet. Locate the screws in the middle of EIA unit 21, the bottom of EIA unit 22, the middle of EIA unit 23, and the bottom of EIA unit 23 for the front of the cabinet.
- c. You can route the cables down through the cable management tray or through the holes in the sides of the chassis. If you route the cables down through the cable management tray, allow adequate space below the chassis for cable management.

Orient the left and right mount shelf brackets with the notched portion toward the service aisle. Attach the shelf brackets to the cabinet rails, by using six 1/4–20 x 1/2-in. Phillips panhead screws with lock washers per bracket. Tighten the screws. See Figure 7 on page 15.



SJ000663

Figure 7. Shelf brackets are installed on the rails (cabinet walls are not shown)

3. Tighten the adjusting screws on the shelf brackets.
4. Attach four 10–32 clip nuts to the two rails at the front of the cabinet (service aisle side). See Figure 8 on page 16.

**Note:** If you are installing the director into the bottom of the rack, go to step 4a for the location of the clip. If you are installing the director into the top of the rack, go to step 4b for the location of the clip.

- a. Attach the lower clip nuts to the top of EIA unit 6. Attach the upper clip nuts to the middle of EIA unit 17.
- b. Attach the lower clip nuts to the top of EIA unit 23. Attach the upper clip nuts to the middle of EIA unit 34.

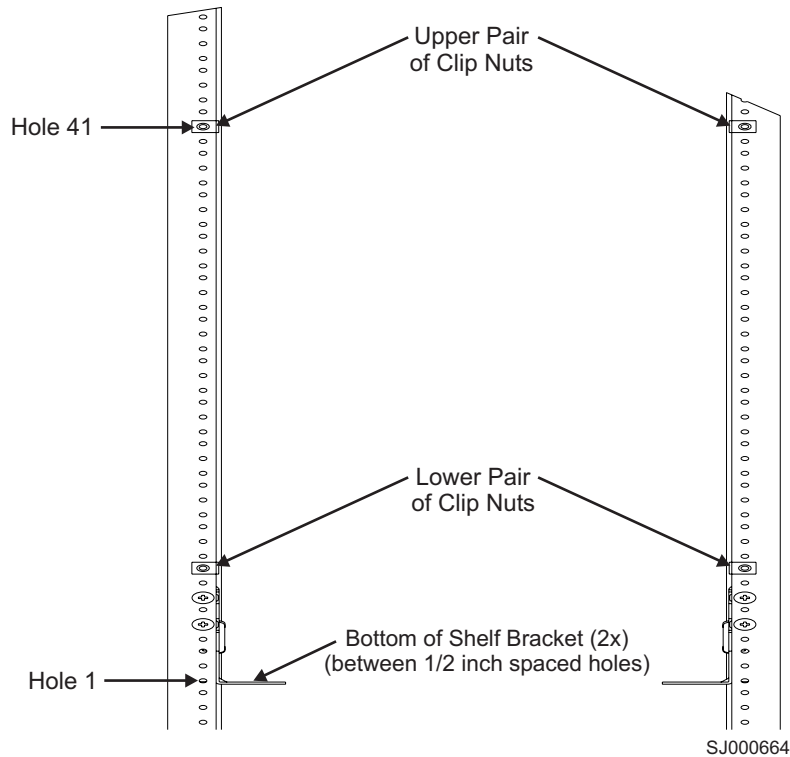

Figure 8. Placing the clip nuts on the rear rails (service aisle side)

5. Disassemble the left and right upper mount bracket assemblies. Save the screws for later use.
6. **Attention:** When you insert screws into the chassis, use the exact screws specified in the procedure. Use of longer screws might damage the chassis. Attach the right and left flat upper mount brackets (see Figure 9 on page 17, items 3a and 4a) to the chassis by using four of the 10-32 x 5/16-in. Phillips-flathead screws (item 5) per bracket. Tighten the screws. Orient the slotted holes in the brackets towards the blower side of the chassis. See Figure 9 on page 17 for orientation.

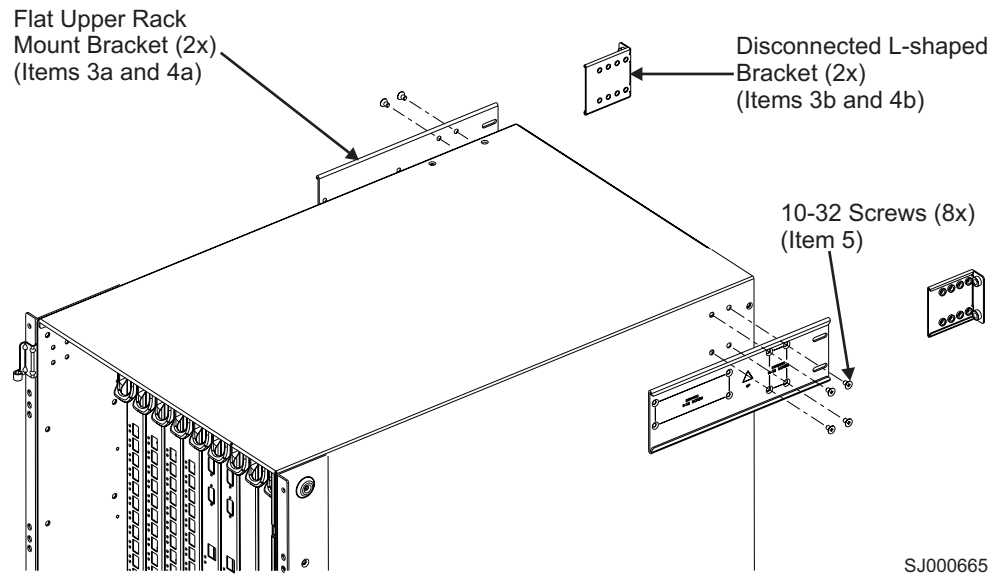

Figure 9. Attaching the right and left flat upper mount brackets to the chassis

7. Attach the two L-shaped upper mount brackets (items 3b and 4b) to the cabinet rails. See Figure 10 for orientation. Use two of the 1/4–20 x 1/2 in. Phillips panhead screws with lock washers per bracket. Tighten the screws.

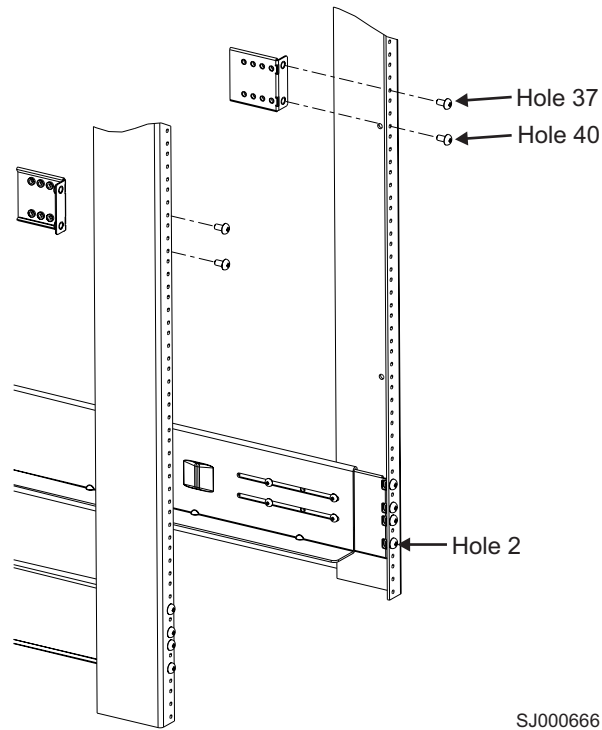

Figure 10. Attaching the L-shaped upper mount brackets to the rails

**Note:** If you are installing the director into the bottom of the rack, go to step 7a on page 18 for the location of the bracket. If you are installing the director into the top of the rack, go to step 7b on page 18 for the location of the bracket.

- a. Attach the lower clip nuts to the top of EIA unit 6. Attach the upper clip nuts to the middle of EIA unit 17.
  - b. Attach the lower clip nuts to the top of EIA unit 23. Attach the upper clip nuts to the middle of EIA unit 34.
8. Route the cables or cords through the cabinet or along any other route that is difficult to reach after you install the chassis.

## Using the lift tool, the 24–inch load plate, and the bridge tool

Step 1 through step 9 on page 19 describe how to use the lift tool (PN 09P2481) and the 24–inch load plate (PN 11P4369) to install a SAN256B in the cabinet. Step 10 on page 19 through step 21 on page 22 describe how to install the bridge tool (PN 18P5855) in the cabinet for the lower director or the upper director. This procedure uses parts from the 14U chassis mount kit. See “Items required” on page 86 for a list of these parts.



>55 kg (121.2 lb)

### CAUTION:

**A fully populated director weighs approximately 96 kg (216 lb) and requires a minimum of two people and a lift tool to install it. (C011)**

**Attention:** Before you install it, verify that the additional weight of the chassis does not exceed the cabinet’s weight limits or unbalance the cabinet. When you calculate the additional weight, include the cards or power supplies that partially extend out of the chassis.



### CAUTION:

**A pinch point exists between the load plate and the bridge tool.**

Perform the following steps to install the director:

1. Assemble the lift tool if it is not assembled. The assembly and disassembly instructions are included with the lift tool.
2. Attach the 24–inch load plate to the lift tool.
3. Remove the power supplies and blower assemblies from the director to reduce the weight.
4. Move the lift tool next to the pallet that contains the director.
  - a. Adjust the load platform to the same height.
  - b. Slide the director from the pallet onto the load platform.
  - c. Center the switch on the load platform.
5. Attach the retention straps around the drawer.
6. If the load platform is not at its lowest position, lower the load platform to its lowest position.
7. Move the lift tool to a position near the rear of the cabinet. See Figure 11 on page 19.

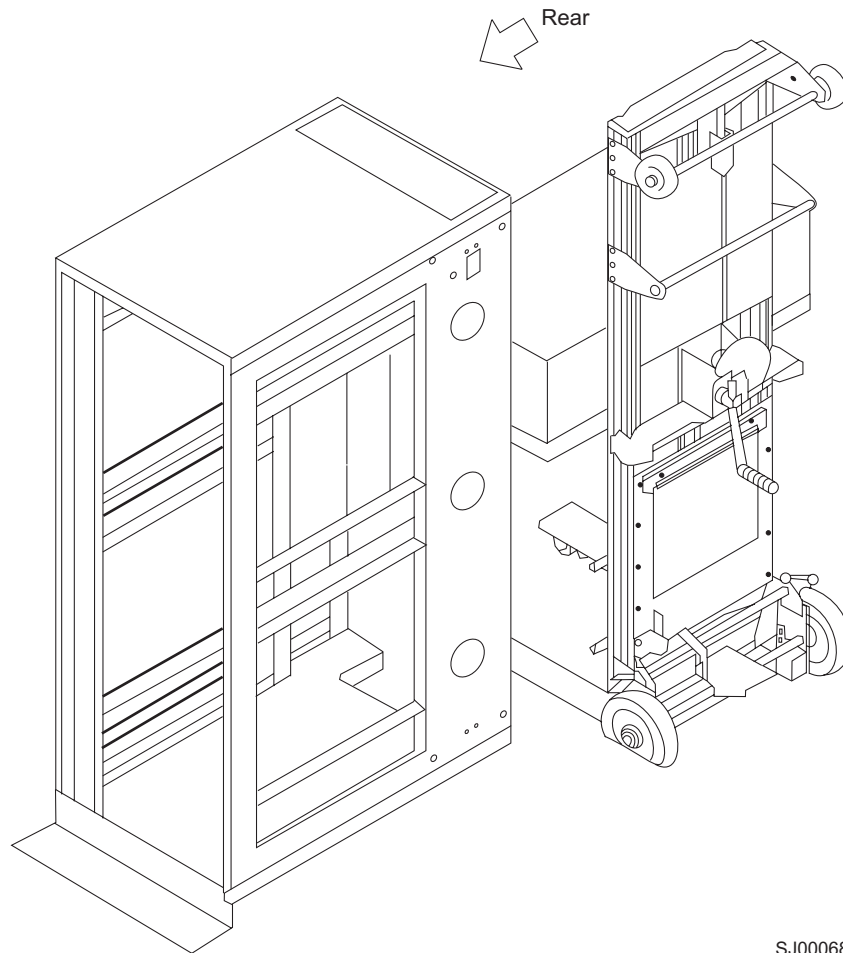

SJ000682

Figure 11. Rear view of cabinet and lift tool

**Note:** If you are passing through a narrow passage or door, it might be necessary to rotate the drawer on the load platform.

8. Set the wheel brake by pressing down on the wheel brake pedal.
9. Locate the anti-tips bars. If they are not attached, attach them to the lift tool by performing step 9a through step 9d. If the anti-tip bars were previously attached, go to step 10.
  - a. Pull up on the leg lock pins and insert the anti-tip bars inside the legs.
  - b. Pull on the legs and anti-tip bars to ensure that they are locked into position.
  - c. Raise the platform to allow enough room to attach the anti-tip bracket.
  - d. Secure the anti-tip bars by using the anti-tip bracket and bolt.
10. If you are installing the lower director, go to step 11. If you are installing the upper director, go to step 12 on page 20.
11. For the lower director, install the bridge tool by completing the following steps:
  - a. Remove the bridge tool from the box and adjust the two supports 45°.
  - b. Hold the bridge tool between the two vertical supports near EIA unit 3, and move the two supports another 45°. Make sure that the following conditions are met:
    - The two-pin section of the support is on the back of the vertical support.
    - The one-pin section of the support is on the front of the vertical support.

- c. Align the two-pin section of the support on the back of the vertical rail with the bottom and middle holes in EIA unit 3.
- d. Align the one-pin section of the support on the front of the vertical rail with the middle hole in EIA unit 1.

**Note:** Tilt the bridge tool towards the back of the cabinet approximately 45° to make it easier to align the two-pin and the one-pin sections with the vertical support.

- e. Lock the shelf into position. See Figure 12.



SJ000680

Figure 12. Locking the shelf into position

12. For the upper director, install the bridge tool by completing the following steps:
  - a. Remove the bridge tool from the box and adjust the two supports 45°.
  - b. Hold the bridge tool between the two vertical supports near EIA unit 20, and move the two supports another 45°. Make sure that the following conditions are met:
    - The two-pin section of the support is on the back of the vertical support.
    - The one-pin section is on the front of the vertical support.

**Note:** Tilt the bridge tool towards the back of the cabinet approximately 45° to make it easier to align the two-pin and one-pin sections with the vertical support.

- c. Align the two-pin section of the support on the front of the vertical rail with the bottom hole and the middle hole in EIA unit 20.
  - d. Align the one-pin section of the support on the front of the vertical rail with the middle hole in EIA unit 18.
13. Turn the winch crank counterclockwise, 1/4 turn, to set the winch brake.
  14. Set the wheel brake and place the wheel chocks around the wheels.



15. Remove the retention straps.
16. Slide the switch into the cabinet.
17. Remove the wheel chocks, release the wheel brake, and move the lift tool away from the cabinet.
18. Reinstall the power supplies and blower assemblies.
19. Fasten the two flat left and right upper mount brackets that are on the chassis to the two L-shaped upper left and right cabinet mount brackets. Use the two screws that were set aside in step 5 on page 16. Tighten the screws. See Figure 13.

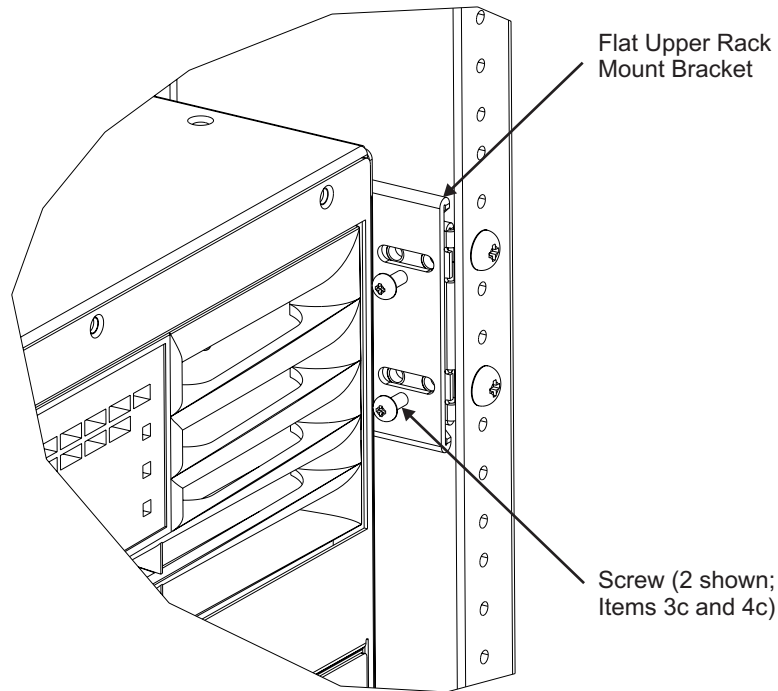

SJ000667

*Figure 13. Attaching the mount brackets to the cabinet rails*

20. Fasten the port side of the chassis to the cabinet rails. Use two of the 10–32 x 5/8-in. Phillips panhead screws with washers on each side. Tighten the screws. See Figure 14 on page 22 for the location of the screws.

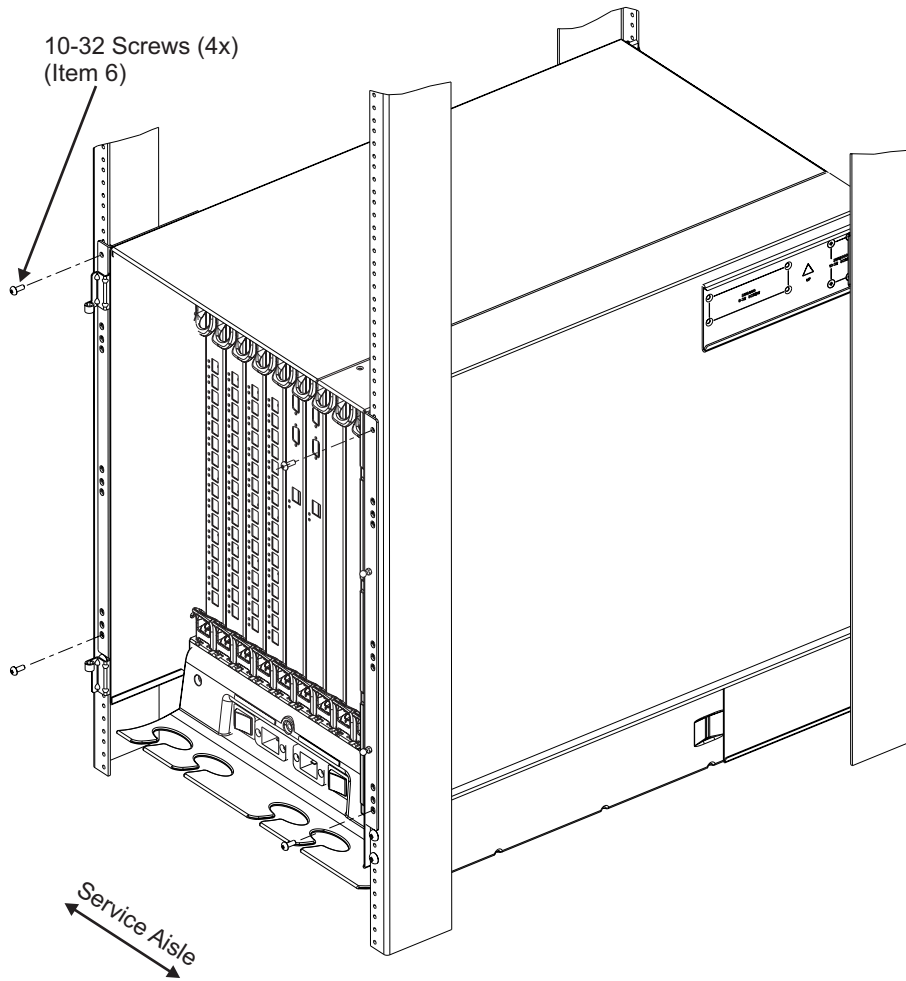

SJ000668

Figure 14. Attaching the port side of the chassis to the cabinet rails

21. Reinstall the door after you put the chassis in place. See Figure 15 on page 23.
  - a. Ensure that the spring-loaded pins that are on both door hinges are retracted. Push the levers into the notches.
  - b. Align the door hinges with the chassis portion of the hinges.
  - c. Release the pins by pushing the levers out of the notches.

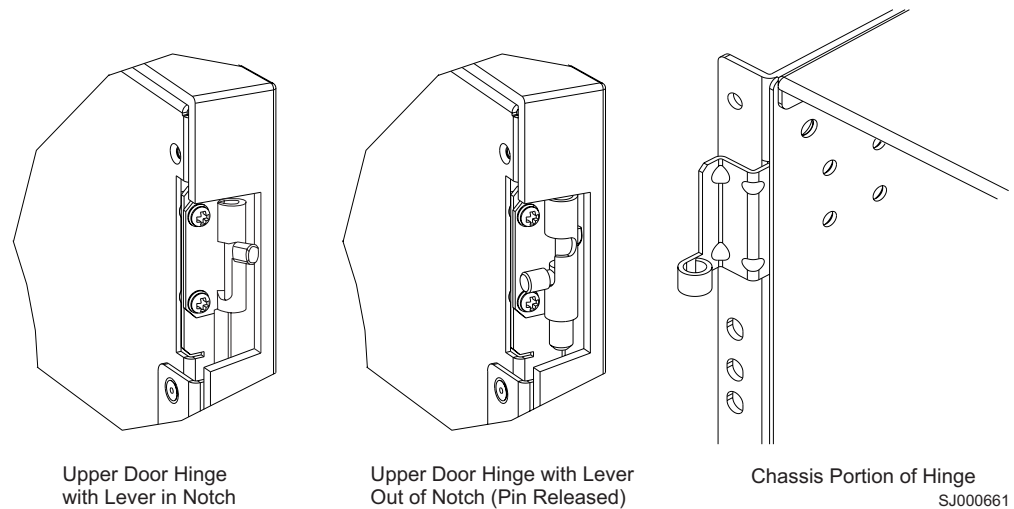

Figure 15. Reinstalling the chassis door

22. Uninstall the bridge tool and return it to its original box.

**Note:** For turning on the power and for the configuration instructions, see Chapter 3, “Starting and configuring the director,” on page 27.

**Attention:** Do not connect the switch to the network until the IP addresses are correctly set.

## Removing a SAN256B from the cabinet

Step 1 through step 5 describes how to use the lift tool (PN 09P2481) and the 24-inch load plate (PN 11P4369) to remove a director from the cabinet. Step 6 through step 17 on page 25 describes how to remove the bridge tool (PN 18P5855) from the cabinet.

Perform the following steps to remove a director:

1. Assemble the lift tool if it is not assembled. The assembly and disassembly instructions are included with the lift tool.
2. Remove both power cords from the director.
3. Remove the power supplies and blower assemblies to reduce the weight.
4. Remove the chassis door from the chassis.
  - a. Open the door 90°.
  - b. Support the door to prevent it from falling.
  - c. Push the spring-loaded lever on the upper hinge up and into the notch in the hinge. See Figure 5 on page 13.
  - d. Push the spring-loaded lever on the lower hinge down and into the notch in the hinge. Pull the door out and towards you.
  - e. Pull the door away from the chassis.
5. Remove the two 10-32 x 5/8 in. Phillips panhead screws with washers on each side. See Figure 13 on page 21 for the location of the screws.
6. If you are replacing the lower director, go to step 7. If you are replacing the upper director, go to step 8 on page 24.
7. Install the bridge tool by completing the following steps:
  - a. Remove the bridge tool from its box and adjust the two supports 45°.

- b. Hold the bridge tool between the two vertical supports near EIA unit 3.
  - c. Move the two supports another 45°. Make sure that the following conditions are met:
    - The two-pin section of the support is on the back of the vertical support.
    - The one-pin section of the support is on the front of the vertical support.
  - d. Align the two-pin section of the support on the back of the vertical rail with the bottom and middle holes in EIA unit 3.
  - e. Align the one-pin section of the support on the front of the vertical rail with the middle hole in EIA unit 1.
- Note:** Tilt the bridge tool towards the back of the cabinet approximately 45° to make it easier to align the two-pin and one-pin sections with the vertical support.
- f. Lock the shelf into position.
8. For the upper director, install the bridge tool by completing the following steps:
    - a. Remove the bridge tool from its box and adjust the two supports 45°.
    - b. Hold the bridge tool between the two vertical supports near EIA unit 20.
    - c. Move the two supports another 45°. Make sure that the following conditions are met:
      - The two-pin section of the support is on the back of the vertical support.
      - The one-pin section of the support is on the front of the vertical support.
    - d. Align the two-pin section of the support on the back of the vertical rail with the bottom and middle holes in EIA unit 20.
    - e. Align the one-pin section of the support on the front of the vertical rail with the middle hole in EIA unit 18.
    - f. Lock the shelf into position.
  9. Locate the anti-tip bars and if they are not attached, attach them to the lift tool. If anti-tip bars were previously attached, go to step 10.
    - a. Pull up on the leg-lock pins and insert the anti-tip bars inside the legs.
    - b. Pull on the legs and anti-tip bars to ensure that they are locked into position.
    - c. Raise the platform to allow enough room to attach the anti-tip bracket.
    - d. Secure the anti-tip bars with the anti-tip bracket and bolt.
  10. Move the lift tool to a position near the rear of the cabinet.
  11. Turn the winch crank clockwise to raise the switch. Move the lift tool into position in front of the cabinet while you align the 24-inch load plate with the line on the bridge tool.
  12. Turn the winch crank counterclockwise 1/4 turn to set the winch brake.
  13. Set the wheel brake. Place the wheel chocks around the wheels.



>55 kg (121.2 lb)

**CAUTION:**

**A fully populated SAN256B weighs approximately 96 kg (216 lb) and requires a minimum of two people and a lift tool to install it. (C011)**



**CAUTION:**

**A pinch point exists between the load plate and the bridge tool.**

14. Slide the switch from the cabinet onto the 24-inch load plate. Center the switch on the platform.
15. Install the retention straps.
16. Remove the wheel chocks, release the wheel brake, and move the lift tool away from the cabinet.
17. Lower the load platform to its lowest position.
18. Remove the bridge tool.



---

## Chapter 3. Starting and configuring the director

**Note:** If a modem is to be used with the director, it should be connected prior to power-on of the director. To install a modem, refer to Appendix C, “Setting up and installing the modems,” on page 115.

Once the director is installed in the cabinet, you must configure it appropriately for it to operate correctly within the network and fabric. Complete the configuration before you connect the director to the fabric by entering the configuration commands through the active CP blade. You must first provide power to the chassis, CP blades, and port blades before you can configure the director. Follow the steps in the order presented in this chapter to correctly configure the director.

The director configuration includes the following parameters:

- IP addresses (or “native” IP address), host names, subnet masks, and gateway addresses for both CP blades
- IP address and subnet mask for the director
- Director name
- Director status policies
- Domain ID for the director (optional)
- WWN for the director

**Note:** The director WWN is initially set by the factory to match the license ID (which is based on the chassis serial number). The WWN can be changed, but the license ID cannot be modified.

The configuration information is automatically mirrored to the standby CP blade, which allows the most current configuration to remain available even if the active CP blade fails. The configuration information for the director is stored in the WWN blade and the flash memory of the CP blades. The configuration can be backed up to a workstation (uploaded) and then downloaded to the active CP blade if necessary.

After the IBM service representative has provided power to the director chassis and blades

See “Providing initial power to the director” on page 28, additional basic steps are required for the initial configuration.

The following steps are customer responsibilities:

- Log in to the director  
See “Establishing a serial connection” on page 30.
- Set up IP addresses  
See “Initial configuration parameters” on page 31
- Establish an Ethernet connection (optional).  
See “Establish an Ethernet connection” on page 33.
- Specify director name  
See “Customize a switch name” on page 34.
- Specify domain ID for the director  
See “Set the Domain ID” on page 34.
- Connect to the fabric and establish fabric parameters, including PID settings  
See “Verifying the PID mode and connecting to the fabric” on page 34.

- Enable software licenses, as necessary  
See “Enabling software licenses” on page 35.
- Back up the configuration  
See “Backing up the configuration” on page 36.

## Providing initial power to the director

Perform the following steps to provide ac power to the director:

1. Verify that the ON/OFF switches for each port blade and CP blade are in the on position (see **2** in Figure 16).

**Note:** The port blade On/Off switches are identical to the On/Off switches of the CP blades.

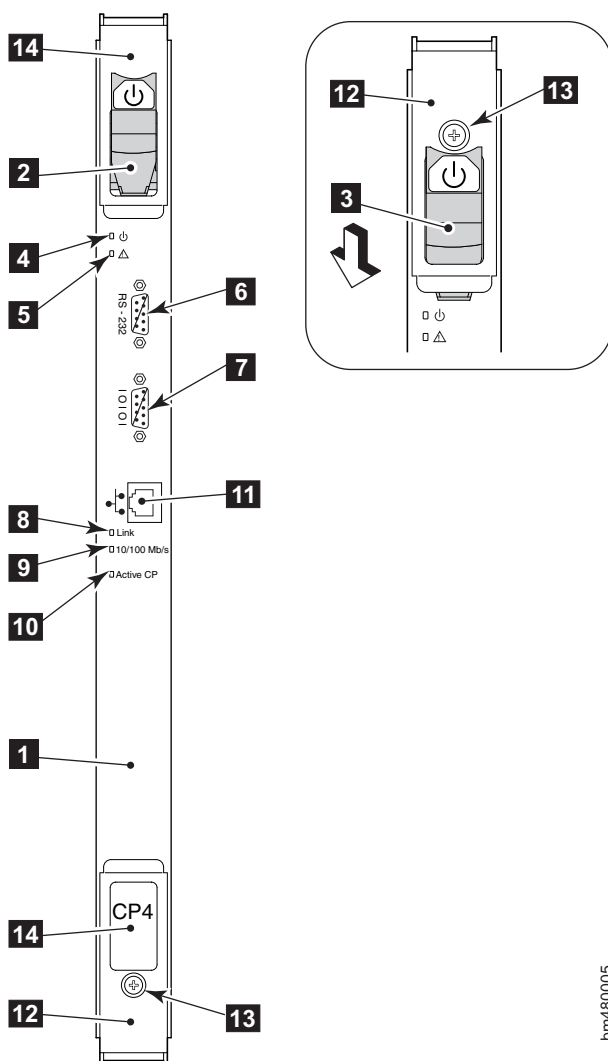

Figure 16. On/Off Switch for a CP4 blade

- |          |                                 |           |                 |
|----------|---------------------------------|-----------|-----------------|
| <b>1</b> | CP4 control processor blade     | <b>8</b>  | Link status LED |
| <b>2</b> | On/Off switch (in On position)  | <b>9</b>  | Link speed LED  |
| <b>3</b> | On/Off switch (in Off position) | <b>10</b> | Active CP LED   |
| <b>4</b> | Power LED                       | <b>11</b> | Ethernet port   |

bm480005



- |          |                      |           |                   |
|----------|----------------------|-----------|-------------------|
| <b>5</b> | Status LED           | <b>12</b> | Ejector           |
| <b>6</b> | RS-232 modem port    | <b>13</b> | Thumbscrew        |
| <b>7</b> | Console port (10101) | <b>14</b> | CP blade ID label |

- Verify that the ac switch covers are installed over the ac switches. These clear plastic covers fit over the ac switches with their edges tucked underneath the outlet covers. They prevent the ac switches from being powered on or off accidentally (see **1** and **5** in Figure 17).

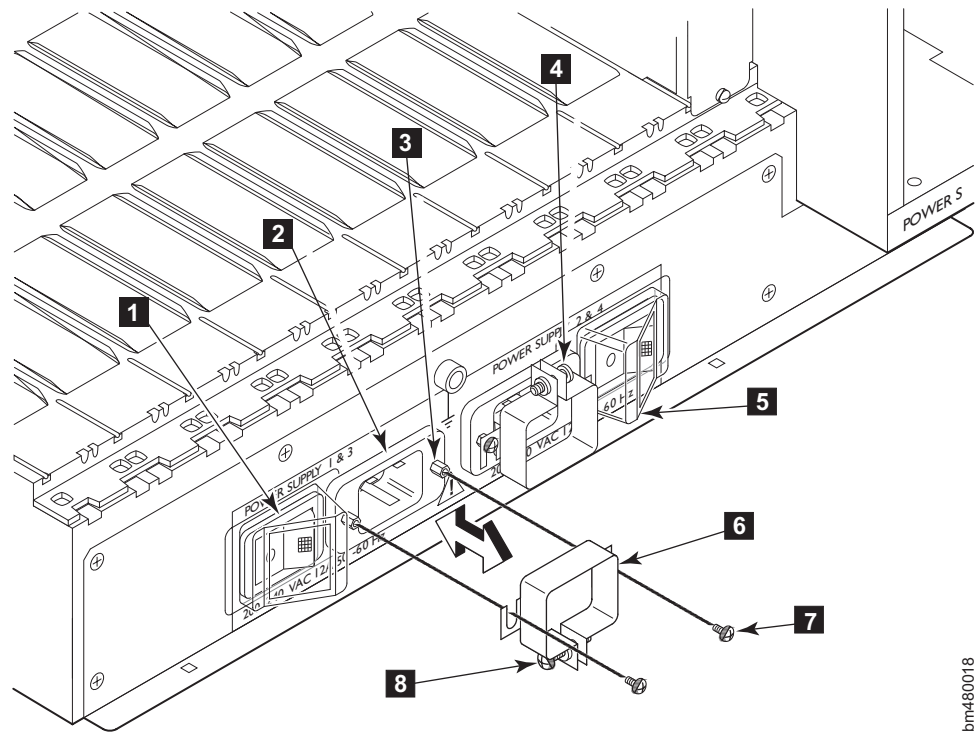

Figure 17. AC panel and power cord retainers

- |          |                     |          |                          |
|----------|---------------------|----------|--------------------------|
| <b>1</b> | Ac switch           | <b>5</b> | Ac switch cover          |
| <b>2</b> | Ac power receptacle | <b>6</b> | Power cord retainer      |
| <b>3</b> | Jack screw          | <b>7</b> | Retainer attaching screw |
| <b>4</b> | Clamping screw      | <b>8</b> | Clamping screw           |

- Connect the ac power cord retainers **6** to the chassis: orient a retainer against the ac panel as shown in Figure 17, place the retainer tabs under the two jack screws **3** on either side of the power receptacle, and tighten the screws **7**. Repeat for the other retainer (note that the power cord retainers are oriented in the same direction as the power receptacles).
- Loosen the clamping screw ( **4** and **8** on each retainer, insert the power cords through the retainers into the power receptacles on the director, and tighten the clamping screws. The power cords are designed to bend to the left, so each should route to opposite sides of the chassis.
- Ensure that the power cord has a minimum service loop of 15 cm (6 in.) available at the connection to the director and is routed so that it is not exposed to stress.

6. Connect the cabinet power distribution units (PDUs) to separate power sources of 200–240 V ac, 47–63 Hz.
7. Make sure that the internal power cords are connected to the separate PDUs and that the other ends are connected to the director ac power receptacles **2**.
8. Route the power cord so that it is not exposed to stress.
9. Flip both green ac power switches to "I" The ac power switches light up green when switched on, and power is being supplied.

The director automatically performs a power-on self-test (POST) by default each time you power on. A POST takes approximately 10 minutes, and is complete when LED activity returns to a standard state. For information about LED light patterns, see Chapter 4, "Monitoring system components," on page 37. Allow the director to run a minimum of 10 minutes to complete POST after powering on before you power the director off.

**Attention:** To prevent potential IP address conflicts, do not connect the director to the network until you configure the IP addresses.

---

## Establishing a serial connection

The initial communication to a SAN256B requires a serial connection. Follow the steps below to establish a serial connection and log in to the director:

1. Verify that the director is powered on and that POST is complete by verifying that all power LED indicators on the port blades and CP blades are displaying a steady green light.
2. Use the serial cable provided with the director to connect the console port on the active CP blade to a computer workstation.

**Note:** The console port is the second serial port from the top of the CP blade (see **10** in Figure 16 on page 28); the active CP blade is indicated by an illuminated (blue) LED. This LED on the standby CP blade should be off (not illuminated). This console port is intended primarily for use during the initial setting of the IP address and for service purposes. If necessary, the adapter on the end of the serial cable can be removed to allow for an RJ-45 serial connection.

3. Access the director using a terminal emulator application (such as HyperTerminal on Windows<sup>®</sup> 95, 2000, or NT, or TERM in a UNIX<sup>®</sup> environment).
4. Disable any serial communication programs running on the workstation (such as synchronization programs).
5. Open the terminal emulator application and configure as follows:
  - For most Microsoft<sup>®</sup> Windows systems, use the configuration parameters shown in Table 2.

*Table 2. Configuration parameters*

Parameter	Value
Bits per second	9600
Data bits	8
Parity	None
Stop bits	1
Flow control	None

- For most UNIX systems, type the string at the prompt:

```
tip /dev/ttyb -9600
```

When the terminal emulator application stops reporting information, press **Enter**. You will receive the following login prompt: CP0 Console Login:

6. Log in to the director as admin. The default password is password.

**Note:** At the initial login, the user is prompted to enter new admin and user passwords.

7. Change the passwords, if desired. Passwords can be 8 to 40 characters long. They must begin with an alphabetic character. They can include numeric characters, the dot (.), and the underscore (\_). Passwords are case-sensitive, and they are not displayed when you enter them on the command line. To skip modifying the password, press **Ctrl-C**.

*Table 3. Example login without changing the password*

```
Fabric OS (swDir)
swDir login: admin
Password:
Please change your passwords now.
Use Control-C to exit or press 'Enter' key to proceed.
Password was not changed. Will prompt again at next login
until password is changed.
swDir:admin>
```

8. View the "Active CP" LED on the CP blades in slots 5 and 6 (see Figure 16 on page 28), or enter the **haShow** command to verify which CP blade is active. The configuration can be modified only through a login session to the active CP blade.

*Table 4. Example screen, verifying active CP blade*

```
swDir: admin> haShow
Local CP (Slot 6, CP1): Active
Remote CP (Slot 5, CP0): Standby
HA Enabled, Heartbeat Up, State Synchronized
```

---

## Initial configuration parameters

The director must be configured before it is connected to the fabric. All of the configuration commands must be entered through the active CP blade, using the serial connection to set the IP addresses. The remainder of the configuration can be completed using an optional Ethernet connection or through the serial connection. The configuration parameters include the following:

- IP address and subnet mask for the chassis
- IP addresses, host names, subnet masks, and gateway addresses for both CP blades
- Director name
- Domain ID for the director (optional)
- WWN for the director

The following basic steps are required for the initial configuration and are described on the following pages.

- Log in to the director.
- Set up IP addresses.

- Establish an Ethernet connection (optional).
- Specify a director name.
- Specify a domain ID for the director.
- Verify that the PID mode matches the fabric and connect the director to the fabric.
- Enable software licenses as necessary.
- Back up the configuration.

## Configuring the director IP addresses

The SAN256B director requires three IP addresses; one for the single logical switch in the director chassis (shown as SWITCH in the **ip"AddrShow"** command), and one for each of the CP blades (CP0 and CP1). These IP addresses are set using the **ipAddrSet** command through the serial connection to the active CP blade.

**Note:** The IP and gateway addresses must reside on the same subnet. The same gateway address must be used for both CP blades (these gateway addresses are referenced for the IP addresses).

Resetting an IP address while the director has active IP traffic such as Fabric Manager, Fabric Watch, SNMP, or other applications can cause traffic to be interrupted or stopped. Changing the IP address causes a domain address format RSCN to be issued.

The addresses 10.0.0.0 through 10.0.0.255 are reserved and used internally by the director. External IPs cannot use these addresses either.

The default IP addresses and host names for the director are as follows:

- 10.77.77.75 for CP0 (the CP blade in slot 5 at the time of configuration)
- 10.77.77.74 for CP1 (the CP blade in slot 6 at the time of configuration)

Configuration changes can only be made through the active CP blade. If the CP blade in slot 5 is not the active CP blade, disconnect the serial cable and connect it to the CP blade in slot 6; then, log in as admin.

Follow these steps to configure the IP addresses for the director and both CP blades (from the active CP blade):

1. Log in to the active CP as admin using the serial cable connection.
2. Set up the director IP address by entering the **ipaddrset -sw 0** command at the prompt.

```
swDir:admin> ipAddrSet -sw 0
```

Enter the requested information at the prompts. Unlike the M12 and M14 model directors, the only valid configuration for the SAN256B is as a single domain (single logical switch), so you only need to specify the -sw 0 IP address. There is no -sw 1 in the SAN256B.

3. Set up the CPO blade IP address by entering the **ipaddrset -cp 0** command at the prompt, including "0" for the CP blade in slot 5.

```
swDir:admin> ipAddrSet -cp 0
```

Enter the requested information at the prompts.

4. Set up the CP1 blade IP address by entering the **ipaddrset -cp 1** command at the prompt, including "1" for the CP blade in slot 6.

```
swDir:admin> ipAddrSet -cp 1
```

Enter the requested information at the prompts.

The following is a sample IP configuration for the director (sw -0) and the two CP blades (cp0 and cp1).

```
swDir:admin> ipaddrset -sw 0
Ethernet IP Address [0.0.0.0]: 123.123.123.120
Ethernet Subnetmask [0.0.0.0]: 123.123.123.123
Fibre Channel IP Address [0.0.0.0]:
Fibre Channel Subnetmask [0.0.0.0]:
Issuing gratuitous ARP...Done.
Committing configuration...Done.
swDir:admin> ipaddrset -cp 0
Host Name [cp0]:
Ethernet IP Address [10.77.77.75]: 123.123.123.121
Ethernet Subnetmask [0.0.0.0]: 123.123.123.123
Gateway IP Address [0.0.0.0]: 123.123.123.124
IP address is being changed...Done.
Committing configuration...Done.
swDir:admin> ipaddrset -cp 1
Host Name [cp1]:
Ethernet IP Address [10.77.77.74]: 123.123.123.122
Ethernet Subnetmask [0.0.0.0]: 123.123.123.123
Gateway IP Address [0.0.0.0]: 123.123.123.124
IP address of remote CP is being changed...Done.
Committing configuration...Done.
swDir:admin> reboot
```

5. Reboot the director by typing **reboot** at the prompt.

The terminal serial port can be used to monitor error messages through a serial connection. It is not recommended as a command interface during normal operations. If this port is not going to be in ongoing use, remove the serial cable and protect the port from dust by replacing the shipping cap.

---

## Establish an Ethernet connection

After using a serial connection to configure the IP addresses for the director, you can connect the active CP blade to the local area network (LAN) if desired.

**Note:** Connecting the CP blades to a private network/VLAN is recommended.

By establishing an Ethernet connection, you can complete the director configuration using either the serial session or a Telnet session, or through the graphical management interfaces: Web Tools and Fabric Manager. However, you must ensure that the director is not modified from other connections at the same time.

To establish an Ethernet connection to the director, follow these steps:

1. Remove the shipping plug from the Ethernet port on the active CP blade.
2. Insert one end of an Ethernet cable into the Ethernet port.
3. Connect the other end to an Ethernet 10/100 Base-T LAN.

The director can now be accessed by remote connection using any of the available management tools, such as Telnet, Web Tools, or Fabric Manager.

4. To complete any additional director configuration procedures through a Telnet session, log in to the director by Telnet, using the admin login. The default password is password.

---

## Customize a switch name

The *switch* name of the director can be up to 15 characters long; can include alpha, numeric, and underscore characters; and must begin with an alpha character. The default name for the director is "swDir".

**Note:** Changing the name causes a domain address format RSCN to be issued.

To customize the name, follow these steps:

1. Enter the **switchName** command with the new name in quotes.

```
swDir:admin> switchName "swDirector5"  
Committing configuration...  
Done.  
swDirector5:admin
```

2. Record the new name for future reference.

---

## Set the Domain ID

Each switch in the fabric must have a unique Domain ID. The Domain ID can be set using the **configure** command. You can also allow the Domain ID to be automatically set. The default Domain ID for the director is "1".

To set the Domain ID, follow these steps:

1. Enter the **fabricshow** command to determine the current Domain IDs available.
2. Enter the **switchdisable** command to disable the director.
3. Enter the **configure** command.
4. Enter **y** at the "Fabric parameters" prompt:

```
Fabric parameters (yes, y, no, n): [no] y
```

5. Enter a unique Domain ID:

```
Domain: (1..239) [1] 3
```

6. Complete the remaining prompts or press **Ctrl+D** to accept the other settings and to exit.
7. Enter the **switchEnable** command to reenabte the director.

---

## Verifying the PID mode and connecting to the fabric

Before connecting the director to the fabric, verify that the port identifier (PID) mode on the director matches the other switches in the fabric. This parameter must be set identically on all switches in the fabric. This parameter is set using the **configure** command. For information on PID mode, refer to the *Brocade Fabric OS Administrator's Guide*. Before starting, also refer to "Managing cables" on page 50 for more information on how to organize and route cables to minimize potential problems with large numbers of fiber optic cables.

To connect the director to the fabric, follow these steps:

1. Add SFP transceivers and cables to the fibre channel ports, as required.  
The ports are color-coded to indicate which ones can be used in the same port group for trunking. Trunking port groups can be up to eight ports. Trunk groups are displayed by shaded or nonshaded ports. The ports and cables used in trunking groups must meet specific requirements. For a list of these requirements, refer to the "ISL Trunking" section of the *Brocade Fabric OS Administrator's Guide*.
2. Position one of the SFP transceivers so that the key is oriented correctly to the port. Insert the transceiver into the port until it is firmly seated and the latching mechanism clicks.  
Transceivers are keyed so that they can only be inserted with the correct orientation. If a transceiver does not slide in easily, ensure that it is correctly oriented. For instructions that are specific to the transceiver model, refer to the transceiver manufacturer's documentation.
3. Position a cable so that the key (the ridge on one side of the cable connector) is aligned with the slot in the transceiver; then, insert into the transceiver until the latching mechanism clicks.  
Cables are keyed so that they can only be inserted with the correct orientation. If a cable does not slide in easily, ensure that it is correctly oriented.
4. Repeat step 1 through step 3 for the remaining ports.
5. Organize the cables as required. For recommendations regarding cable management, refer to "Managing cables" on page 50.
6. Verify the director for switch and port status by entering the **switchShow** command.  
The **switchShow** command provides detailed information about the director.
7. Verify fabric connectivity by entering the **fabricShow** command.  
The **fabricShow** command provides general information about the fabric.

---

## Enabling software licenses

To determine which licenses are currently enabled, enter the **licenseShow** command.

*Table 5. Example of viewing enabled licenses*

```
swDir:admin> licenseshow
AAbbccDDeeFFeeGG:
    Web license
    Zoning license
    Extended Fabric license
    Fabric Watch license
    Performance Monitor license
    Trunking license
    Security license
```

In the example above, the license key is AAbbccDDeeFFeeGG. Make sure you keep a hardcopy of your license key in a secure location for emergency reference.

The 64-bit chassis ID is required to obtain and activate licenses for the director. The chassis ID is available through the **licenseIdShow** command.

Both the **licenseShow** and **licenseIdShow** commands must be entered through the active CP blade.

For information about activating licenses, refer to the *Brocade Fabric OS Administrator's Guide*.

---

## Backing up the configuration

Save all key configuration data for the director, including license key information, and upload it to a host for emergency reference. Routine backups of the configuration are recommended to ensure the current configuration is available if needed.

After all zoning configurations and other changes are complete, back up the configuration by entering the **configUpload** command at the prompt.

The **configUpload** command uploads the director configuration to the server so that it is available for downloading to a replacement director, if necessary.

An easy way to backup configuration information is to enable logging on your Telnet session and then running the following commands and saving the output in a file on a secure host. Once you enable logging, run the following commands:

- **configShow**
- **ipaddrShow**
- **licenseShow**
- **switchShow**

Also consider keeping hardcopy versions of key data such as passwords, license keys, and IP addresses. This is sensitive information and should be kept in a secure location.

**Note:** Passwords are not saved in the configuration file, and are not uploaded during a **configUpload**. Password information should be saved in hardcopy in a secure location for emergency reference, subject to your security and password management policy.



---

## Chapter 4. Monitoring system components

The SAN256B is engineered for reliability and requires no routine operational steps or maintenance. This chapter provides information about determining the status of each component (using LEDs and CLI commands). Refer to the following sections for LED and CLI information about each director component:

- “Port blade status”
- “CP blade status” on page 40
- “Power supply status” on page 43
- “Blower assembly status” on page 44
- “WWN card status” on page 46

You can also set up monitoring alerts using SNMP, syslog, or software features such as Fabric Watch, Web Tools, and Performance Monitoring. Refer to the *Brocade Fabric Watch Administrator's Guide*, *Web Tools Administrator's Guide*, and the *Brocade Fabric OS Administrator's Guide* (which includes information on Advanced Performance Monitoring) for additional information.

---

### Port blade status

Perform the following to determine the status of a port blade:

1. Check the LED indicators on the port blade (see Figure 18 on page 38 for the LED locations, on an FC4-16 blade on the left, or an FC4-32 blade on the right). The LED patterns may temporarily change during POST and other diagnostic tests; for information about how to interpret the LED patterns, refer Table 6 on page 39.
2. Check the port blade status using the **slotShow** command.

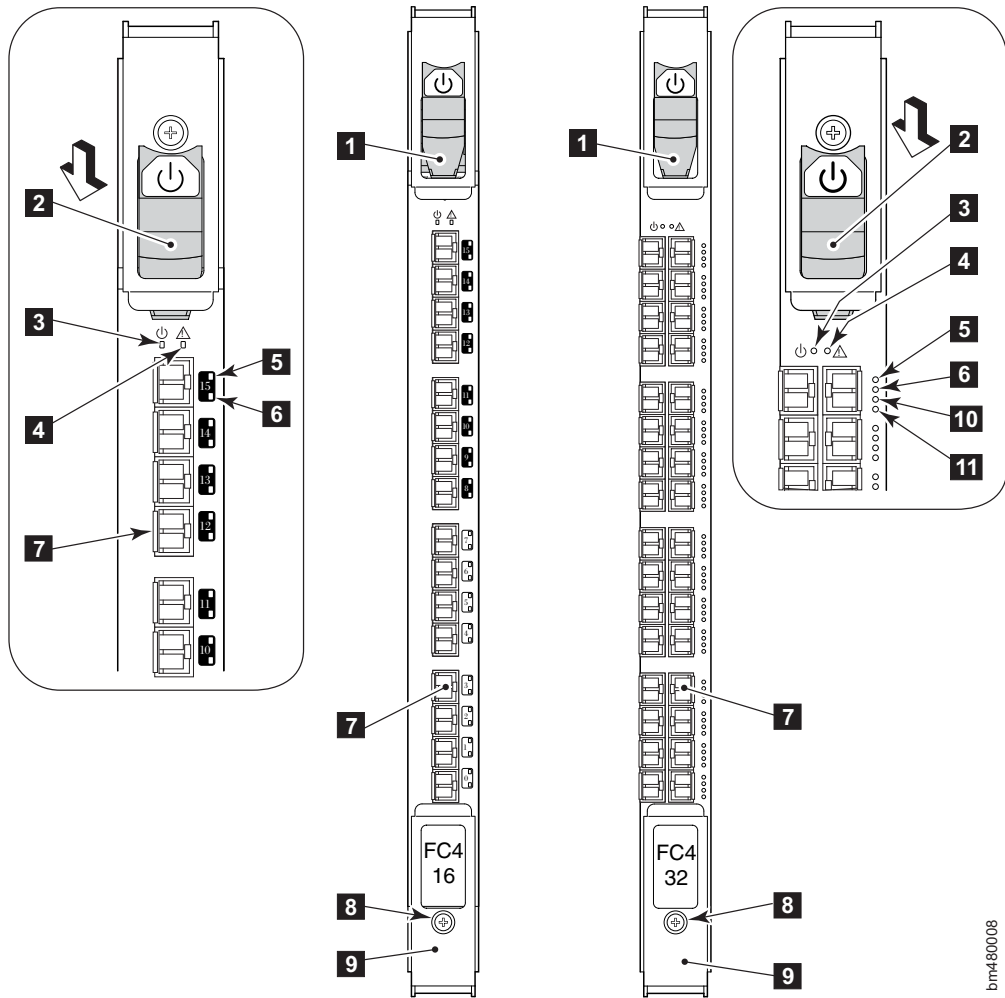

bm480008

Figure 18. FC4-16 and FC4-32 port blades

- |          |                                 |           |   |
|----------|---------------------------------|-----------|---|
| <b>1</b> | On/Off Switch (in On position)  | <b>7</b>  | Fibre Channel Port  |
| <b>2</b> | On/Off Switch (in Off position) | <b>8</b>  | Thumb Screw   |
| <b>3</b> | Power LED                       | <b>9</b>  | Ejector   |
| <b>4</b> | Status LED                      | <b>10</b> | Port Speed LED for the FC4-32, this LED indicates the Port Speed for the right port   |
| <b>5</b> | Port Speed LED                  | <b>11</b> | Port Status LED for the FC4-32, this LED indicates the Port Status for the right port |
| <b>6</b> | Port Status LED                 |           |   |

Table 6 describes the port blade LEDs patterns. It includes the reference numbers in Figure 18 on page 38, the possible LED color and flashing patterns, the corresponding hardware status, and the recommended actions for those patterns.

Table 6. Port blade LED descriptions

LED name, location	Color of LED	Status of hardware	Recommended Action
Power <b>3</b>	Steady green	The port blade has incoming power.	No action is required.
	No light (LED is off)	The port blade does not have incoming power.	Ensure that the blade is firmly seated and has power.
Status <b>4</b>	No light (LED is off)	The port blade is either healthy or does not have power.	Verify that the Power LED is on.
	Steady amber	The port blade is faulty.	Ensure that the blade is firmly seated and check the status with the <b>slotShow</b> command. If the LED remains amber, contact IBM.
	Slow-flashing amber (on 2 seconds; off 2 seconds)	The port blade is not seated correctly or is faulty.	Pull the blade out and reseal it. If the LED continues to flash, replace the blade.
	Fast-flashing amber (on 1/2 second; off 1/2 second)	The environmental range is exceeded.	Check for out-of-bounds environmental condition, and correct it.
Port Speed <b>5</b>	No light (LED is off)	The port is either set to 1 Gbps mode, or does not have incoming power.	Verify that the Power LED is lit. Use the <b>portCfgSpeed</b> command to change mode.
	Steady green	Port is set to 2 Gbps mode.	No action is required.
	Steady amber	Port is set to 4 Gbps mode	No action is required.

Table 6. Port blade LED descriptions (continued)

LED name, location	Color of LED	Status of hardware	Recommended Action
Port Status <b>6</b>	No light (LED is off)	Port blade does not have incoming power or there is no light or signal carrier detected.	Verify that the Power LED is lit, check the transceiver and the cable.
		Polling is in progress.	Allow 60 seconds for polling to complete
		The connected device is configured in an offline state.	Verify the status of the connected device
	Steady green	Port is online (connected to an external device) but has no traffic.	No action is required.
	Slow-flashing green (on 1 second; off 1 second)	Port is online but segmented, indicating a loopback plug or cable, or an incompatible switch.	Verify that the correct device is connected to the director.
	Fast-flashing green (on 1/4 second; off 1/4 second)	Port is in internal loopback (diagnostic).	No action is required.
	Flickering green	Port is online, with traffic flowing through the port.	No action is required.
	Steady amber	Port is receiving light or signal carrier, but is not yet online.	No action is required.
	Slow-flashing amber (on 2 seconds; off 2 seconds)	Port is disabled due to diagnostic tests or the <b>portDisable</b> command.	Reset the port from the workstation. <b>Note:</b> The <b>portCfgPersistentDisable</b> command is persistent across reboots in Fabric OS v5.0.1
	Fast-flashing amber (on 1/2 second; off 1/2 second)	The transceiver or the port is faulty.	Change the transceiver or reset the switch from workstation
Alternating green and amber	The port is bypassed.	Reset the port from the workstation.	

## CP blade status

Perform the following to determine the status of a CP blade:

1. Check the LED indicators on the CP blade (see Figure 19 on page 41 for the locations). The LED patterns may temporarily change during POST and other diagnostic tests; for information about how to interpret the LED patterns, see Table 7 on page 42.
2. Check CP blade status using the **slotShow** and **hashow** commands.

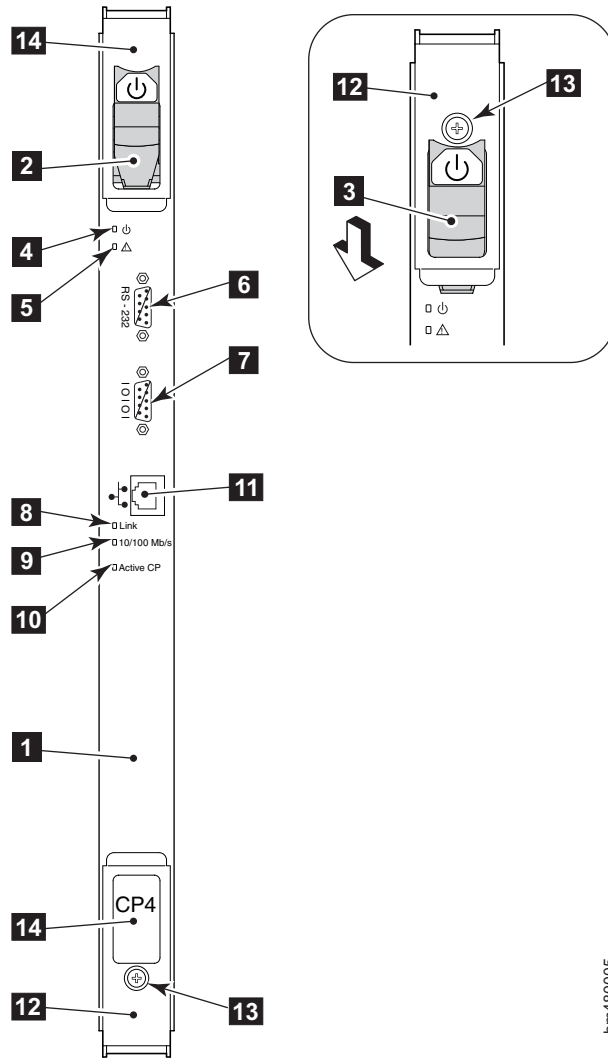

bm480005

Figure 19. Front of CP4 blade

- |          |                                 |           |                   |
|----------|---------------------------------|-----------|-------------------|
| <b>1</b> | CP4 control processor blade     | <b>8</b>  | Link status LED   |
| <b>2</b> | On/Off switch (in On position)  | <b>9</b>  | Link speed LED    |
| <b>3</b> | On/Off switch (in Off position) | <b>10</b> | Active CP LED     |
| <b>4</b> | Power LED                       | <b>11</b> | Ethernet port     |
| <b>5</b> | Status LED                      | <b>12</b> | Ejector           |
| <b>6</b> | RS-232 modem port               | <b>13</b> | Thumbscrew        |
| <b>7</b> | Console port (10101)            | <b>14</b> | CP blade ID label |

Table 7 on page 42 describes the CP blade LED patterns. It lists the name, reference number, and possible colors of each LED. It also lists the status of the switch that is associated with each LED color and action that you can take in response to that status.

Table 7. CP blade LED patterns

LED name, location	Color of LED	Status of hardware	Action
Power 4	Steady green	CP blade has incoming power.	No action is required.
	No light (LED is off)	CP blade does not have incoming power.	Ensure that the CP blade is firmly seated and has power.
Status 5	No light (LED is off)	The CP blade is either healthy or does not have incoming power.	Verify that the Power LED is lit.
	Steady amber	The CP blade is faulty or the switch is still booting.	Ensure that the CP blade is firmly seated and the switch has completed booting. If the LED still displays amber, contact IBM.
	Slow-flashing amber (on 2 seconds; off 2 seconds)	The CP blade is not seated correctly, or is faulty.	Pull the CP blade out and reseal it. If the LED continues to flash, replace the CP blade.
	Fast-flashing amber (on 1/2 second; off 1/2 second)	The environmental range is exceeded.	Check for out-of-bounds environmental condition and correct it.
Ethernet Link Status 8	No light (LED is off)	Either an Ethernet link is not detected or the CP blade does not have incoming power.	Ensure that the CP blade has power. Verify that the Ethernet cable is firmly seated and the device at the other end of the link is functioning.
	Flickering green and amber	The link is healthy, with traffic flowing through the port.	No action is required.
Ethernet Link speed 9	No light (LED is off)	Either the link speed is 10 Mbps or the CP blade does not have incoming power.	Ensure that the CP blade has power. <b>Note:</b> To force a persistent Ethernet link speed, type the <b>ifModeSet</b> command.
	Steady green	The link speed is 100 Mbps.	No action is required.
Active CP 10	Steady blue	Active CP blade	No action is required.
	No light (LED is off)	Standby CP blade	No action is required.

## Power supply status

The following LEDs are on each power supply:

- Power LED ( **3** in Figure 20)
- Predictive Failure LED ( **4** )
- Fail LED ( **5** )

To determine the status of a power supply:

1. Check the LED indicators on the power supply (see Figure 20). The LED patterns may temporarily change during POST and other diagnostic tests; for information about how to interpret the LED patterns, refer to Table 8 on page 44.

2. Check power supply status by entering the **psShow** command.

In the CLI interface, the power supply status displays OK, Absent, or Faulty. If a power supply is absent or faulty, contact IBM to order replacement parts, as necessary.

Figure 20 shows the location of the LEDs and other parts on the power supply.

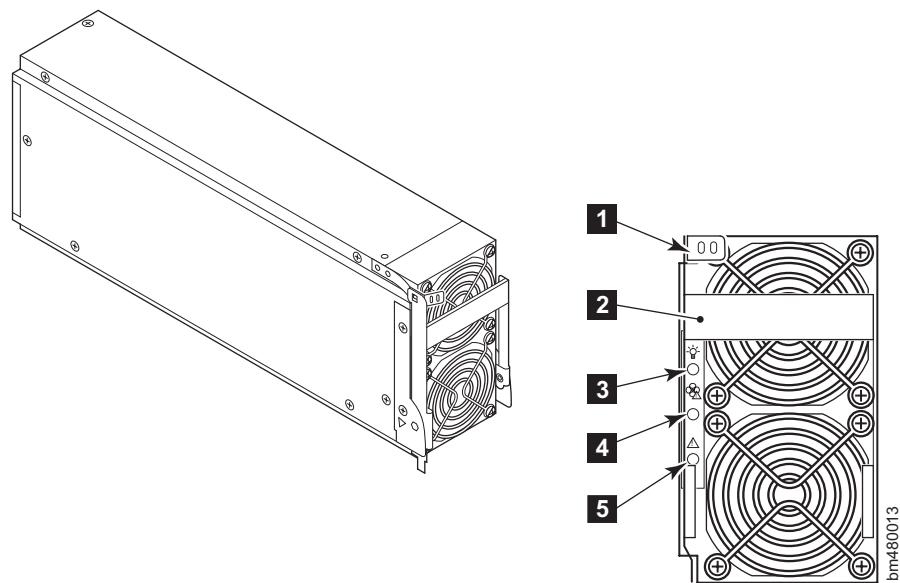

Figure 20. Power supply LEDs

<b>1</b>	Locking tab
<b>2</b>	Handle
<b>3</b>	Power LED
<b>4</b>	Predictive Failure LED
<b>5</b>	Fail LED

Table 8 on page 44 describes the power supply LED patterns. It lists the name, reference number in Figure 20, and possible colors of each LED. It also lists the status of the switch that is associated with each LED color and action that you can take in response to that status.

Table 8. Power supply LED patterns

LED Name, location	Color of LED	Status of hardware	Action
Power <b>3</b>	No light (LED is off)	The power supply does not have incoming power and is not providing power to the director.	Ensure the following: <ul style="list-style-type: none"> <li>• The power supply is firmly seated.</li> <li>• The director has incoming power.</li> <li>• Both power cables are connected.</li> <li>• The ac power switches are on.</li> </ul>
	Steady green	The power supply has incoming power and is providing power to the director.	No action is required.
Predictive Failure <b>4</b>	No light (LED is off)	The power supply is either healthy or does not have incoming power.	Check the Power LED.
	Flashing amber	The power supply is about to fail due to a failing fan inside the power supply.	Replace the power supply.
Fail <b>5</b>	No light (LED is off)	The power supply is either healthy or does not have incoming power.	Check the Power LED.
	Steady amber	Either the director has power but this power supply does not (ac switch might be off), or the power supply has failed.	Ensure that the correct ac power switch is on and the power supply is seated. If the LED still displays, replace the power supply.
	Flashing amber	The power supply is unable to supply power.	Verify that the incoming power meets the requirements listed in "Power specifications" on page 101.

## Blower assembly status

The following LEDs are on each blower assembly:

- Power LED
- Fault LED

To determine the status of a blower assembly:

1. Check the LED indicators on the blower assembly (see Figure 21 on page 45). The LED patterns may temporarily change during POST and other diagnostic tests; for information about how to interpret the LED patterns, refer to Table 9 on page 45.
2. Check the blower assembly status using the **fanShow** command.  
In the CLI interface, the status for each blower assembly displays OK, Absent, or Faulty. The RPM of each fan in the assembly is also provided. If a blower assembly is absent or faulty, contact IBM to order replacement parts, as necessary.



Figure 21 shows the location of the LEDs and other parts on the blower assembly.

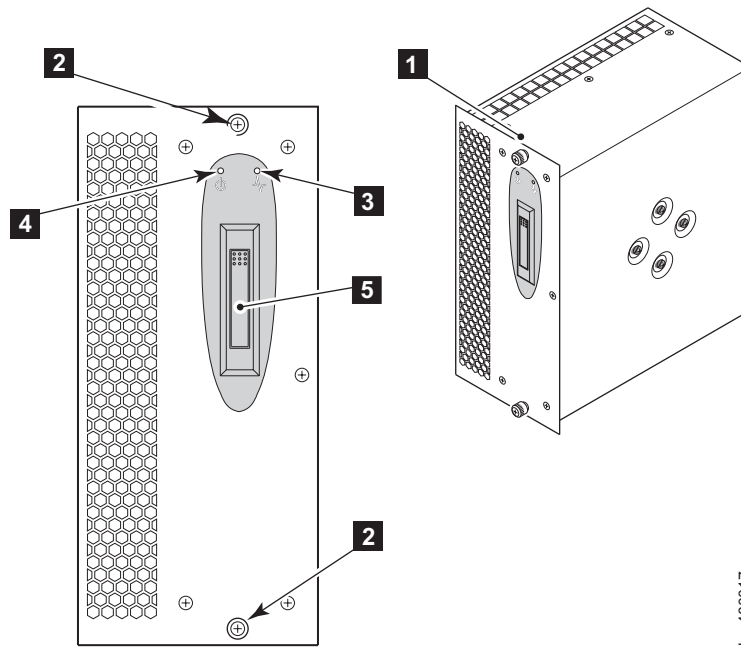

bm480017

Figure 21. Blower assembly LEDs and other parts

Item	Description
<b>1</b>	Blower assembly
<b>2</b>	Captive screw
<b>3</b>	Fault LED
<b>4</b>	Power LED
<b>5</b>	Handle

Table 9 describes the blower assembly LED patterns. It lists the name, location, and possible colors of each LED. It also lists the status of the switch that is associated with each LED color and action that you can take in response to that status.

Table 9. Blower assembly LED patterns

LED name, location	Color of LED	Status of hardware	Action
Power <b>4</b>	No light (LED is off)	The blower assembly does not have incoming power.	Ensure that the blower assembly is firmly seated and has power.
	Steady green	The blower assembly has incoming power.	No action is required.

Table 9. Blower assembly LED patterns (continued)

LED name, location	Color of LED	Status of hardware	Action
Fault <b>3</b>	No light (LED is off)	The blower assembly is either healthy or does not have incoming power.	Ensure that the blower assembly has incoming power.
	Steady amber	The blower assembly has a failure (full or partial).	Replace the blower assembly.
	Slow-flashing amber (on 2 seconds; off 2 seconds)	The blower assembly is not seated correctly or is faulty.	Pull out the blower assembly and reseal it. If the LED continues to flash, replace the blower assembly.
	Fast-flashing amber (on 1/2 second; off 1/2 second)	The environmental range is exceeded.	Check for an out-of-bounds environmental condition, resolve any problems, and reseal unit. If the LED continues to flash, replace the unit.

## WWN card status

The WWN card and bezel are located at the top of the chassis on the blower assembly side. The bezel covers the WWN card, allowing the LEDs to shine through. The LED patterns can temporarily change during a POST and other diagnostic tests. The WWN card and bezel provide a consolidated LED view of:

- The incoming power to, and status of, the port blades in slots 1–4 and 7–10
- The incoming power to, and status of, the CP blades in slots 5 and 6
- The incoming power to the four power supplies

To determine the status of the WWN card and the information stored on the card:

1. Check the LED indicators on the WWN bezel (see Figure 22 on page 47) and verify that they reflect the actual status of the components.

For information about how to interpret the LED patterns, refer to Table 12 on page 48.

2. Check the WWN card status using the commands listed in Table 10 if you have problems viewing or modifying the data stored on the WWN card. Difficulty retrieving or modifying this data could indicate a WWN card failure.

Table 10. Data Stored on the WWN Card

Data	Related Commands
WWN values	<b>wwn</b> , <b>chassisShow</b>
Data about the chassis and WWN card	<b>chassisShow</b>
Ethernet and fibre channel IP address information for the CP blades	<b>ipAddrShow</b> , <b>ipAddrSet</b>
History log information	<b>historyShow</b> , <b>historyLastShow</b>
Name of switch	<b>switchName</b>

3. If the error log or serial console display error messages that indicate problems with WWN units (see Table 11 on page 47), the WWN card might have failed. WWN units correspond to information specific to the WWN card and are displayed by typing the **chassisShow**. command.

Table 11. Messages That Can Indicate WWN Card Failure

Type of Message	Sample Error Message
WWN unit fails its FRU (field replaceable unit) header access.	0x24c (fabos): Switch: switchname, error EMI2C_TIMEOUT, 2, WWN 1 I2C timed out: state 0x4
WWN unit is being faulted.	0x24c (fabos): Switch: switchname, Critical EMWWN_UNKNOWN, 1, Unknown WWN #2 is being faulted
WWN unit is not present or is not accessible.	0x24c (fabos): Switch: switchname, Error EMWWN_ABSENT, 2, WWN #1 not present
Writing to the FRU history log ( <b>hilSetFruHistory</b> ) has failed.	0x24c (fabos): Switch: switchname, Error EMHIL_FAIL, 2, HIL Error: hilSetFruHistory failed, rc=-3 for SLOT 3

Figure 22 shows the WWN card and bezel and the location of the LEDs and other parts of the bezel. The WWN bezel display provides a consolidated view of the power and status of the port blades, the CP blades, and the power supplies.

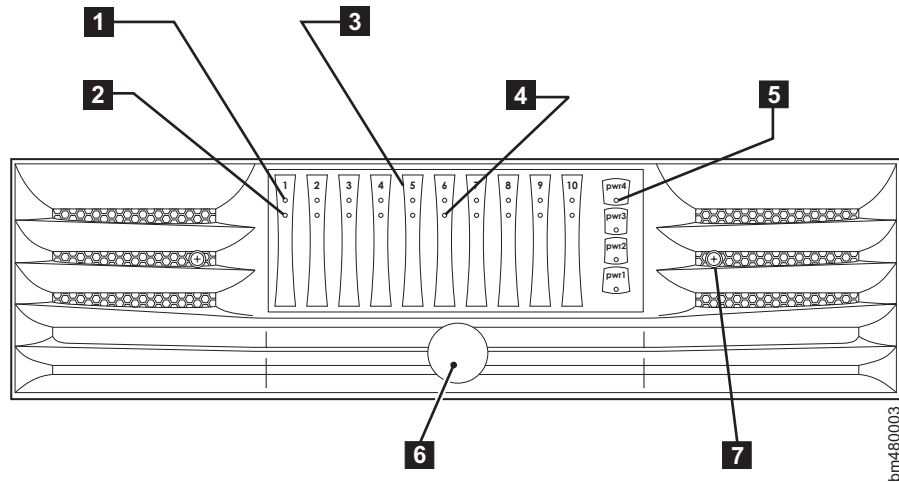

Figure 22. LEDs on the WWN card and bezel

- |          |                       |          |                                   |
|----------|-----------------------|----------|-----------------------------------|
| <b>1</b> | Port blade Power LED  | <b>5</b> | Power supply Power LED/Status LED |
| <b>2</b> | Port blade Status LED | <b>6</b> | Badge                             |
| <b>3</b> | CP blade Power LED    | <b>7</b> | Captive Screw                     |
| <b>4</b> | CP blade Status LED   |          |                                   |

Table 12 on page 48 describes the WWN card LED patterns and the recommended actions for those patterns for the director.

Table 12. WWN bezel LED patterns

LED location/type	Color	Status	Action
Port blade/CP blade Power <b>1</b> and <b>3</b>	Steady green	Power is OK.	No action is required.
Port blade/CP blade Status <b>2</b> and <b>4</b>	Steady amber	Blade is faulty.	Check blade.
	No light (LED is off)	Blade is OK.	No action is required.
<b>Note:</b> If a blade slot or power supply bay has a filler panel installed, the corresponding LEDs on the WWN card do not light up.			
Power supply Power/Status <b>5</b>	Steady green	Power is OK.	No action required.
	Steady amber	Power supply is faulty.	Check power supply.

**Note:** If a Status LED on the WWN card flashes, the Power LED on the WWN card also flashes for increased visibility.

---

## Chapter 5. Removing and installing components

These removal and installation procedures in this chapter are to be completed only by qualified IBM service representatives. Follow the procedures in this chapter to remove or install any of the field replaceable units (FRUs) in the SAN256B director. These procedures can be completed in relatively short amounts of time without the use of any special tools. The director can continue to operate during most of the FRU replacements when you follow the conditions specified in the procedures. See Chapter 2, "Installing and removing a SAN256B director," on page 9 for instructions on how to install or remove an entire director. See Chapter 6, "Replacing the chassis," on page 85 for instruction on how to replace the director chassis.

**Attention:** Refer to "Safety and environmental notices" on page xi before performing any service or installation procedures.

This chapter contains the following removal and installation instructions:

- "Removing and installing the chassis door"
- "Managing cables" on page 50 (including "Removing and installing the cable management tray" on page 54)
- "Installing and removing SFPs in a port blade" on page 57
- "Removing and installing a port blade or filler panel" on page 57
- "Removing and installing a CP blade" on page 63
- "Removing and installing a power supply and filler panel" on page 71
- "Removing and installing a blower assembly" on page 76
- "Replacing the WWN bezel and card" on page 79

---

### Removing and installing the chassis door

The chassis door must be installed to ensure that the director meets electromagnetic interference (EMI) and other regulatory certifications. Use this procedure to remove and replace the chassis door.

**Attention:** To avoid damaging the chassis and door, do not open the door more than 90 degrees.

#### Time required

Less than 5 minutes.

#### Items required

Replacement chassis door

#### Removing the chassis door

Perform the following steps to remove the chassis door:

1. Open the door to an angle of approximately 90 degrees.
2. Push the spring-loaded pin on the upper hinge up and into the notch in the hinge. See Figure 23 on page 50.

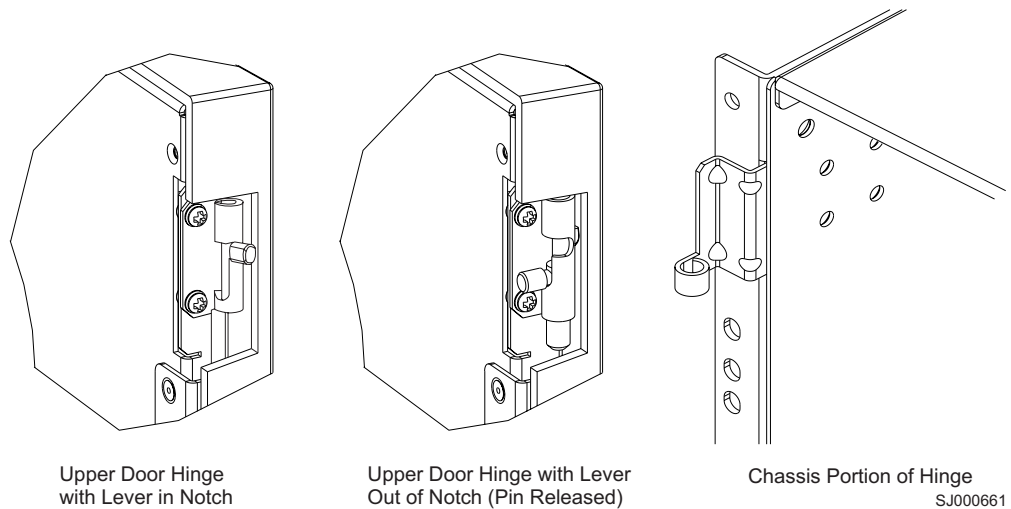

Figure 23. Upper door hinge

3. Support the door to prevent it from falling.
4. Push the spring-loaded pin on the lower hinge down and into the notch.
5. Pull the door away from the chassis.

## Installing the chassis door

Perform the following steps to install a door in the chassis (see Figure 23 for illustrations of the upper hinge):

1. Ensure that the levers on the spring-loaded pins on both hinges on the door are pushed into the notches.
2. Position the door at approximately 90 degrees to the chassis.
3. Align the spring-loaded pins with the chassis portion of the hinges.
4. Release the pins by pushing the levers out of the notches.

---

## Managing cables

The SAN256B director is designed to accommodate all of the cables required in a full 256-port configuration. The cable management tray and shortened chassis door introduced in the SAN256B allow for simpler cable management. The new tray allows additional space between the chassis and shelf and can be installed without service disruption. The new shortened chassis door design enables the fiber cables to exit the front of the vertical rack mounting rails. Nevertheless, considerable care must be taken in arranging these cables to facilitate removal and installation of the FRUs, as well as to maintain the minimum bend radius of the fiber optic cables. Additional care and planning may be required when installing cables for two fully populated directors in a single C36 cabinet.

Use the following guidelines for managing cables:

- You can route the cables in a variety of ways, including the following:
  - Routing the cables down through the cable management tray
  - Routing cables out either side of the chassis
  - Routing cables through the cable channels on the sides of the cabinet
  - Using patch panels

- To keep the LEDs visible and to prevent having to disconnect the cables when removing neighboring blades, route fiber-optic cables and other cables directly downwards, instead of across adjacent blades or in front of the power supplies.
- Do not route the cables in front of the air exhaust vent, which is located at the top of the port side of the chassis.
- Do not use cable ties for securing cables. They can be easily overtightened and can break the optical cables.
- Leave space to access attachment to the grounding strap connector, which is located on the chassis directly below the two CP blades. (See **3** in Figure 25 on page 53.)
- Leave at least 1 m (3.28 ft) of slack for each fiber-optic cable. This slack:
  - Provides room to remove and replace the port blades
  - Allows for inadvertent movement of the cabinet
  - Prevents the cables from being bent to less than the minimum bend radius  
The minimum bend radius for a 50-micron cable is 3.05 cm (2 in.) under full tensile load and 3.048 cm (1.2 in.) with no tensile load.
- Use the cable guides that are provided with the switch to group the cables by trunking ports (groups of four neighboring ports). These guides help to keep individual ports accessible by keeping the cables evenly spaced. They also help to provide clearance when removing a neighboring blade. If ISL Trunking is in use, grouping the cables by trunking group is recommended. The ports are color-coded to indicate which ports can be used in the same ISL Trunking group: four ports marked with solid black ovals alternate with four ports marked with oval outlines.

Figure 24 on page 52 shows an orderly organization of the cables on the port side of the director. In this example the cables for each 32-port blade are routed directly in front of each blade and are out of the way of other components. Note that for illustration purposes, only half of the port blades are shown with cables attached.

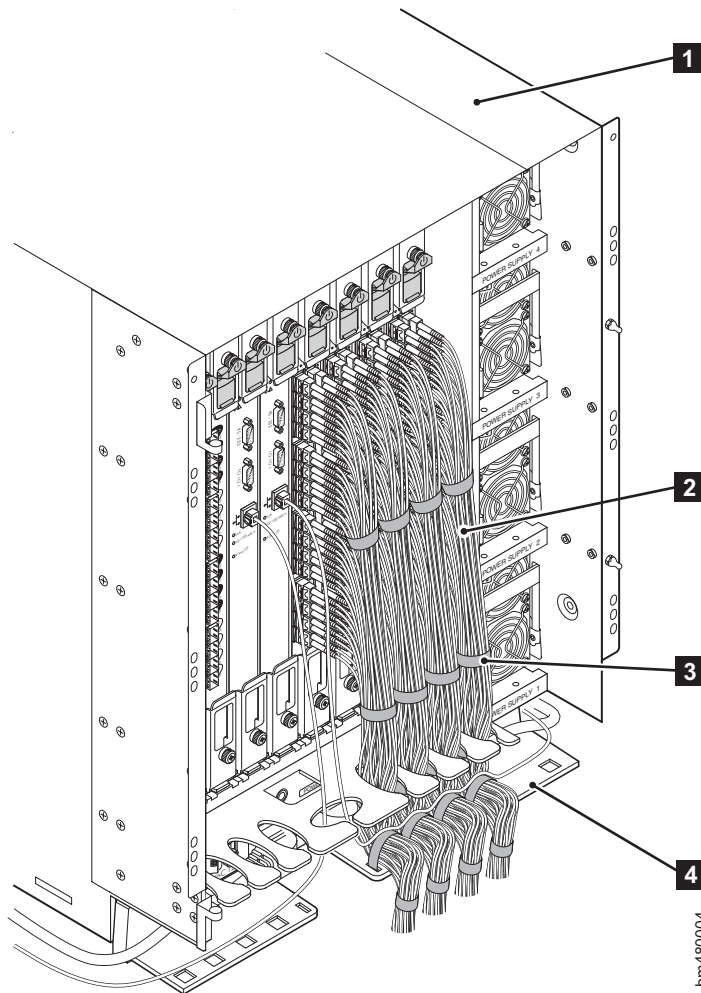

Figure 24. Effective cable management

- |          |                       |
|----------|-----------------------|
| <b>1</b> | Director chassis      |
| <b>2</b> | Cables                |
| <b>3</b> | Velcro straps         |
| <b>4</b> | Cable management tray |

Two items are provided to assist with cable management:

- **Cable management tray** (see Figure 25 on page 53).-- The cable management tray is attached to the bottom of the chassis (see Figure 28 on page 55) and can be used to route the power cables and other cables down below the chassis or out the sides of the chassis.



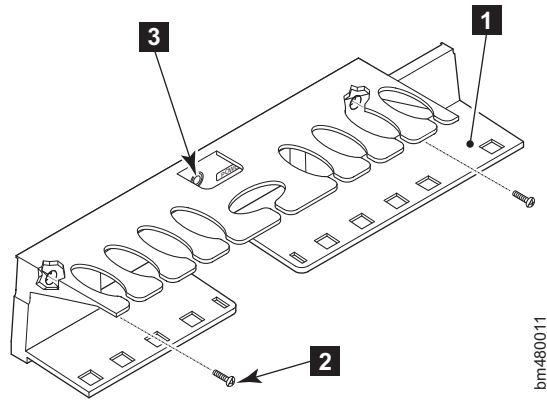

bm480011

Figure 25. Cable management tray

- 1** Cable management tray
- 2** Screws (x2)
- 3** Ground strap connector hole

- **Cable guides** --A set of cable guides (see Figure 26) are provided with the director, and can be used to organize the port cables into logical groups. The cable guides do not attach to the chassis. These cable guides can only be used for cable management with 16-port blades.

**Note:** These cable guides should not be used with FC4-32 port blades because the cable count is too dense. Instead, you should use Velcro straps to group cables for these blades.

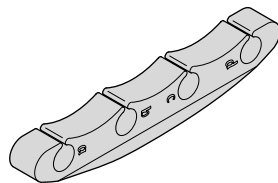

m1400017

Figure 26. Cable guides (pillars)

## Removing and installing the cable management tray

Use this procedure to replace the cable management tray (see Figure 28 on page 55). The director can continue to operate during the installation.

Figure 27 identifies the locations for the ac power connectors and ac power switches on the director chassis. If you are removing or installing the cable management tray while the director is on, you must remove the ac power connector cables *one at a time* in order to route the cables through the cable management tray, and maintain power to the director. If only two power supplies are installed and they are both installed in slots corresponding to the same ac power connector cable, unplugging a single ac power connector cable can power down the entire chassis. See Figure 27 for the locations of the ac power connectors and ac power switches on the director chassis.

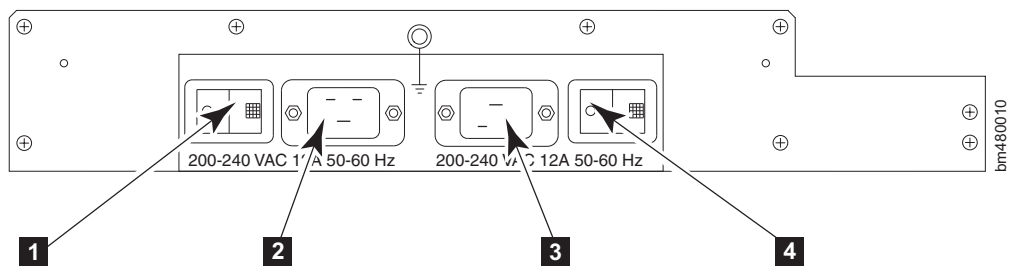

Figure 27. Ac power connectors and ac power switches

- 1** Ac power switch (controls the power for power supplies 1 and 3)
- 2** Ac power connector (connects to the ac power cables for power supplies 1 and 3)
- 3** Ac power connector (connects to the ac power cables for power supplies 2 and 4)
- 4** Ac power switch (controls the power for power supplies 2 and 4)

**Attention:** Do not use a power screwdriver on the cable management tray.

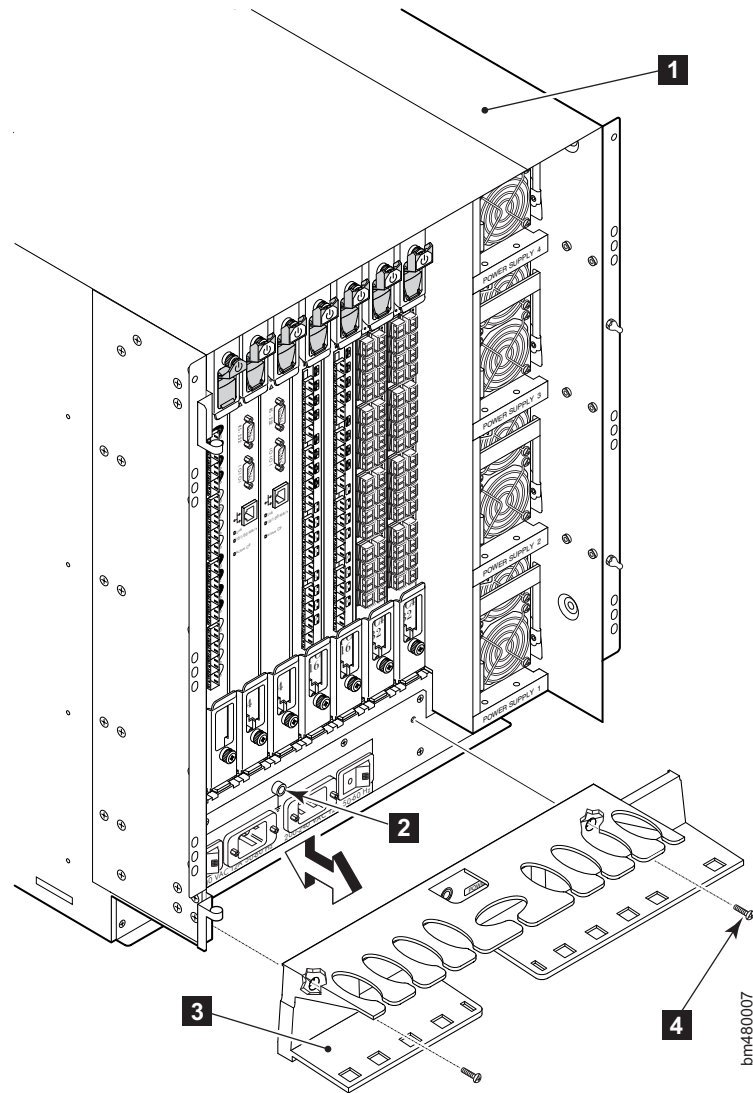

Figure 28. Cable management tray replacement

### Time required

Less than 5 minutes.

### Items required

No. 1 Phillips screwdriver

### Removing a cable management tray

Perform the following steps to remove a cable management tray:

1. If the director is *not* operating: Remove any cables from the tray, including the ac power connector cables and continue with step 2 and then remove the cable management tray from the chassis.  
If the director *is* operating: Remove any cables from the tray, *except* the ac power connector cables.
2. Unscrew the two screws holding the tray to the chassis (see **2** in Figure 25 on page 53 for the location of screws) and save them for reuse.

3. With the ac power connector cables still plugged in, detach the cable management tray approximately 5 inches away from the chassis.
4. Switch one ac power switch off (for example, **1** in Figure 27 on page 54) and remove the corresponding ac power connector cable (for example, remove the cable from **2** in Figure 27 on page 54) from the chassis. Route the ac power connector cable through the tray.
5. Plug the ac power connector cable back in to the connector on the chassis, and switch the ac power switch on.
6. Repeat steps 4 and 5 for the other ac power switch and ac power connector cable. The cable management tray is now removed from the director chassis.

### Installing a cable management tray

Perform the following steps to install a cable management tray:

1. If the director is *not* operating: Orient tray as shown in Figure 28 on page 55, aligning the holes on the tray with the holes on the chassis. Then position and tighten the two screws. The cable management tray is installed. Continue to step 3.  
If the director *is* operating, skip to step 2.
2. Switch one ac power switch off (for example, **1** in Figure 27 on page 54) and remove the corresponding ac power connector cable (for example, remove the cable from **2** in Figure 27 on page 54) from the chassis. Route the ac power connector cable through the new tray.
3. Route the ac power connector cable through the new tray.
4. Plug the ac power connector cable back in to the connector on the chassis, and switch the ac power switch on.
5. Repeat steps 2 and 3 for the other ac power switch and ac power connector cable.
6. Position and tighten the two screws (**2** in Figure 25 on page 53) to secure the cable management tray to the chassis.
7. Arrange the cables through or along the cable management tray as required. Route the ac power connector cables out each side of the chassis, as shown in Figure 24 on page 52.

## Replacing the cable guides (16-port blades only)

You can use the cable guides (see Figure 26 on page 53) to organize the cables for 16-port blades into logical groups, such as according to port quads (sets of four neighboring ports). The cable pillars do not attach to the chassis. Alternatively, you can use Velcro straps for managing cables for both 16- and 32-port blades.

The cable pillars also serve to keep the cables evenly spaced and to hold them away from the 16-port blade, to prevent the cables from bending to less than the minimum bend radius.

**Attention:** Do not route the cables in front of the air exhaust vent.

The minimum bend radius for a 50-micron cable is 2 inches under full tensile load and 1.2 inches with no tensile load.

Tie wraps are not recommended for optical cables, because they are easily overtightened.

To use the cable guides, orient them horizontally and insert the cables into the holes, using a separate hole for each cable. See Figure 26 on page 53.

---

## Installing and removing SFPs in a port blade

To install an SFP, position one of the SFP transceivers so that the key is oriented correctly to the port. Insert the transceiver into the port until it is firmly seated and the latching mechanism clicks. Transceivers are keyed so that they can only be inserted with the correct orientation. If a transceiver does not slide in easily, ensure that it is correctly oriented.

To remove an SFP from a 16-port blade, pull the bale down and out, sliding the SFP transceiver out of the port blade.

To remove an SFP from a 32-port blade, you will need to use a special tool. The director comes with an SFP extraction tool stored on the inside of the chassis door. The SFP extraction tool is designed to remove SFPs from an FC4-32 port blade, where the space is minimal and it is more difficult to fit fingers. Figure 29 displays the SFP extraction tool. To use the SFP extraction tool, slide the SFP extraction tool on to the bale of the SFP and pull it out.



Figure 29. SFP extraction tool

For instructions that are specific to the transceiver model, refer to the transceiver manufacturer's documentation.

---

## Removing and installing a port blade or filler panel

This section describes how to remove and replace FC4-16 port blades and FC4-32 port blades (see Figure 30 on page 58) and blade filler panels (see Figure 31 on page 61) from the director. A filler panel should be removed only when being replaced with a port blade or new filler panel. Any slot that is not occupied by a port blade should be occupied by a filler panel to ensure correct cooling of the chassis and protection from dust. Slots are numbered from one through ten, from left to right, when facing the port side of the directors.

**Attention:** Follow these precautions for all procedures in this section to avoid damaging the port blades or chassis:

- Wear a grounded ESD strap when handling a port blade. The chassis has a grounding connection above the power connectors (see **3** in Figure 25 on page 53).
- Do not force the port blade installation. If the port blade does not slide in easily, ensure that it is correctly aligned inside the rail guides before continuing. Installing a port blade with incorrect alignment damages both the chassis and the replacement part.
- Hold the port blade by the edges of the metal pan. Do not use the ejectors to hold a port blade.
- Disassembling any part of a port blade voids the part warranty and regulatory certifications. There are no user-serviceable parts inside the port blade

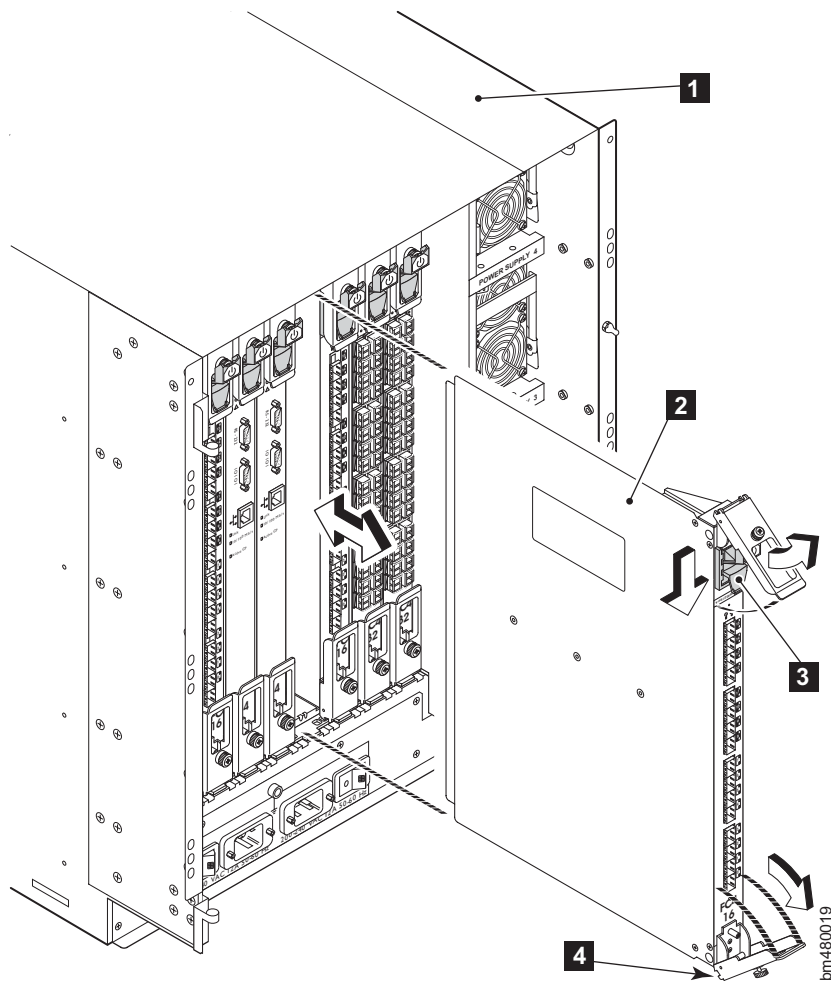

Figure 30. Port blade removal and replacement (16-port blade shown as example)

- |          |  |
|----------|--|
| <b>1</b> | Director chassis                       |
| <b>2</b> | FC4-16 port blade                      |
| <b>3</b> | On/off slider switch (in Off position) |
| <b>4</b> | Ejector (x2)                           |

## Time required

10 minutes or less per port blade or filler panel

## Items required

- ESD (electrostatic discharge) grounding strap
- Workstation computer
- Replacement port blade or filler panel
- Phillips screwdriver
- Small form factor pluggable (SFP) transceivers (as needed)
- Optical cables (as needed)

## Removing a port blade

A failed port blade can be identified by inspecting its LEDs and by using CLI commands to verify status. See “Port blade status” on page 37 for a description of the port blade LEDs. See the *Brocade Fabric OS Administrator’s Guide* for information about how to check the status of hardware components using the CLI.

**Note:** The WWN bezel on the nonport side of the director also displays a power and status LED for each port blade. See “WWN card status” on page 46 for additional information about the WWN bezel and LEDs.

Perform the following steps to remove a port blade:

1. Check the power LED, status LED, port speed LED, and port status LED to identify any possible problems with the port blade. See Figure 18 on page 38 for LED locations on the port blade.
2. Establish a Telnet or console session.  
Before replacing a port blade, establish a Telnet or console connection to determine a failure and verify operation after replacement. Use the **switchShow** command to view the status of blades on the director.
3. Check for adequate cable slack.  
Make sure there is plenty of cable slack to remove a port blade without optical, power, or Ethernet cable obstruction. Refer to “Managing cables” on page 50 for cabling guidelines.
4. Ensure that you have the proper spare part (filler panel or replacement port blade).  
Make sure that the part numbers match for the unit being replaced. The **chassisShow** command displays information about the port blades, including part numbers (xx-000xxxx-xx), serial numbers, and additional status.
5. Ensure that traffic is not flowing through the port blade (all port speed and port status LEDs should be off) prior to disconnecting cables.

**Note:** Before removing any cables from the faulty port blade, make a note of the cable order by identifying each cable by the physical port it attaches to. This reduces confusion during recabling. If multiple port blades are being replaced, replace one blade at a time. Before replacing a port blade, determine if it is the entire blade or only the SFPs that are faulty.

6. Disconnect all cables and remove the SFP transceivers from the port blade.

**Note:** The port density of 32-port blades makes it difficult to remove SFPs without an extraction tool. See “Installing and removing SFPs in a port blade” on page 57 for more information.

7. Turn the port blade off by sliding the on/off switch in the top ejector down, to the off position (see **3** in Figure 30 on page 58). This initiates a hot-swap request.
8. Wait for the power LED to turn off in response to the hot-swap request before uninstalling the port blade.
9. Unscrew the captive screws from the top and bottom ejectors on the port blade using the Phillips screwdriver.
10. Lever both ejectors open simultaneously to approximately 45 degrees, and pull the port blade out of the chassis.
11. If the blade is not being replaced by another port blade, install a filler panel to ensure correct cooling of the chassis and protection from dust. See “Installing a filler panel” on page 63 for instructions.

## Removing a filler panel

Perform the following steps to remove a filler panel:

**Note:** To maintain proper cooling, each blade slot must be filled either with a filler panel or a blade. Replace the filler panel or blade as quickly as possible if the director is on.

Filler panels might not match the illustration below. Some filler panels have a handle, as in Figure 31 on page 61, while others may have pull tabs at the top and bottom of the panel instead of the handle.

1. Unscrew the two captive screws at the top and bottom of the filler panel. See Figure 31 on page 61.
2. Grasp the handle in the middle of the faceplate (or the pull tabs).
3. Slide the filler panel out of the chassis.



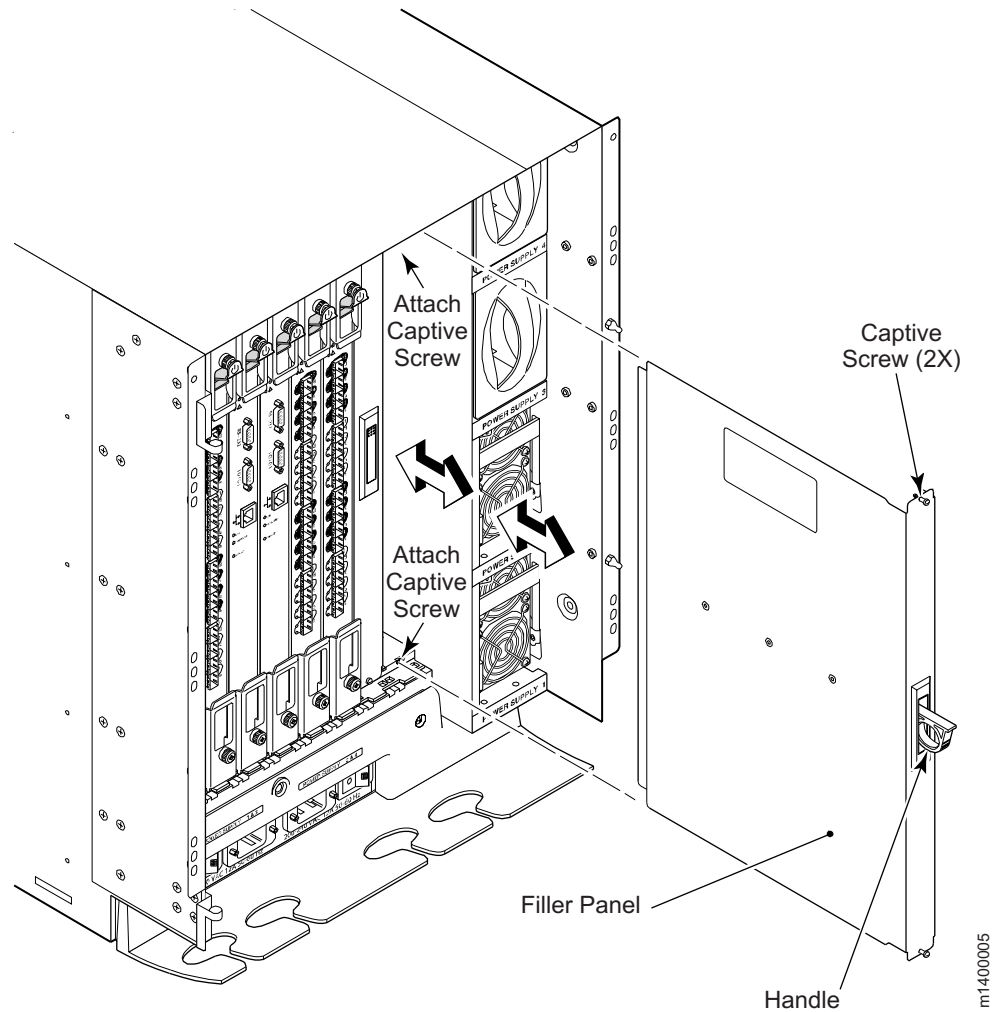

Figure 31. Removing and replacing a filler panel

## Installing a port blade

You can install a port blade in any combination of slots 1–4 and 7–10. The control processor (CP) blades occupy slots 5-6. Any slots that are not occupied by a port blade (or CP blade) must have a filler panel installed to ensure correct cooling of the chassis and protection from dust.

To install a port blade, complete these steps:

1. Orient the port blade so that the ports are at the front of the chassis and the flat side of the port blade is on the left.
2. Open the ejectors to approximately 45 degrees. Align the flat side of the port blade inside the upper and lower rail guides in the slot. (See Figure 32 on page 62, which shows the alignment groove detail with a filler panel installation.) Slide the port blade into the slot, with slight pressure to the left, until it is firmly seated.

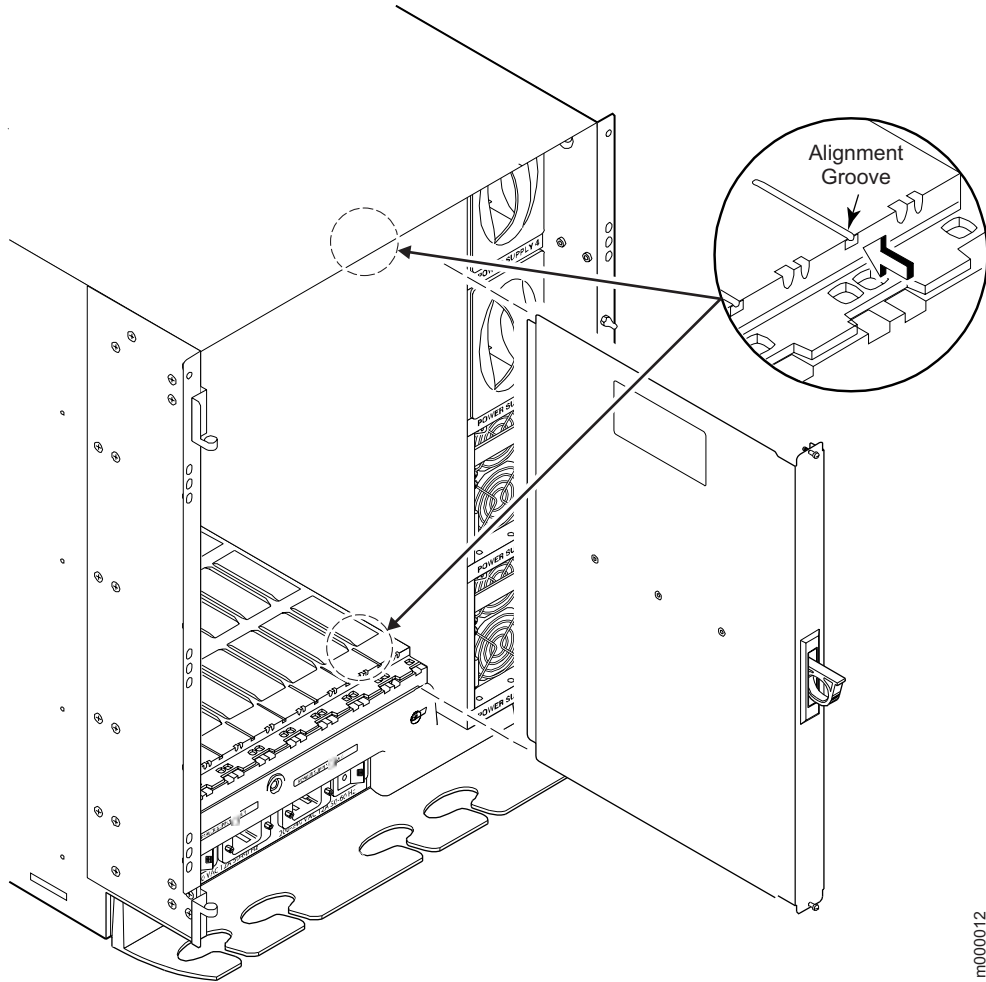

m000012

Figure 32. Guides inside each blade slot

3. Close the ejectors by pushing the handles toward the center of the port blade until the ejectors lock. The levering action of the handles seats the port blade in the slot.
4. Tighten the thumb screw inside each handle, using a Phillips screwdriver.
5. Turn the port blade on by sliding the slider switch in the top ejector up, covering the thumb screw.
6. Verify that the power LED on the port blade is displaying a steady green light (it can take a few seconds to turn on). If it does not turn on, ensure that the port blade is firmly seated.

**Note:** The LED patterns might temporarily change during POST and other diagnostic tests.

7. Install SFP transceivers and cables in the port blade, as required.
8. Group and route the cables as desired. See “Managing cables” on page 50 for additional cabling instructions.

**Attention:** Do not route cables in front of the exhaust vent, which is located at the top on the port side of the chassis.

9. Verify the installation. For information about how to check the status of hardware components using the CLI, See the *Brocade Fabric OS Administrator’s Guide*.

## Installing a filler panel

Follow these steps to install a filler panel. (See Figure 31 on page 61.)

1. Align the filler panel so that the captive screws are at the front of the chassis and the flat side of the panel is on the left.
2. Align the upper and lower edges of the filler panel in the slots (see Figure 32 on page 62).
3. Slide the filler panel into the slot (with slight pressure to the left) until it is firmly seated.
4. Tighten the two captive screws.

---

## Removing and installing a CP blade

Use this procedure to remove and replace a control processor (CP) blade from the director. See Figure 33 on page 67. Each director has two CP blades: one located in slot 5 and the other in slot 6.

**Attention:** Follow these precautions for all procedures in this section to avoid damaging the CP blades or chassis:

- To ensure adequate system pressure for cooling purposes, leave the faulty CP blade in the slot until you are ready to perform the replacement procedure.
- Wear a grounded ESD strap when handling a CP blade. The chassis has a grounding connection above the power connectors (see **3** in Figure 25 on page 53).
- Do not force the CP blade installation. If the blade does not slide in easily, ensure that it is correctly aligned inside the rail guides before continuing. Installing a CP blade with incorrect alignment damages both the chassis and the replacement part.
- Hold the CP blade by the edges of the metal pan. Do not use the ejectors to hold a port blade.
- Disassembling any part of a CP blade voids the part warranty and regulatory certifications. There are no user-serviceable parts inside the CP blade

The director can continue to operate while one CP blade is replaced if the other CP blade continues to operate and no failover occurs. You can prevent failover by entering the **hadisable** command. The active CP blade is determined by the most recent failover.

The configuration on the active CP blade is automatically mirrored to the standby CP blade; this section includes steps to ensure that the new CP blade boots up as the standby CP blade.

The new CP blade automatically assumes the IP address and host name assigned to the slot. If the new CP blade does not have the same firmware as the active CP blade, it must be upgraded or downgraded to the same firmware version.

**Attention:** To ensure adequate system pressure for cooling purposes, leave the faulty CP blade in the slot until you are ready to perform the replacement procedure.

**Attention:** Use the same version of Fabric OS on both CP blades. Using different versions can cause malfunctioning. If the replacement CP blade has a different version, bring both blades to the same firmware version.

Do not attempt to replace the battery on a CP blade.



**CAUTION:**

**Only trained service personnel may replace this battery. The battery contains lithium. To avoid possible explosion, do not burn or charge the battery.**

*Do Not:*

- **Throw or immerse into water**
- **Heat to more than 100°C (212°F)**
- **Repair or disassemble**

**Exchange only with the IBM-approved part. Recycle or discard the battery as instructed by local regulations. In the United States, IBM has a process for the collection of this battery. For information, call 1-800-426-4333. Have the IBM part number for the battery unit available when you call. (C003)**

## Time required

Approximately 30 minutes

## Items required

- ESD (electrostatic discharge) grounding strap
- Workstation computer
- Serial cable provided with the director
- IP address of an FTP server for backing up the director configuration
- Phillips #2 screwdriver
- Replacement control processor (CP4) blade

## Confirming a failed CP blade

Before you replace the CP blade, verify the necessity of replacing the CP blade before continuing. Any of the following events might indicate that a CP blade is faulty:

- The Status LED on the CP blade is amber, or the Power LED is not on.
- The **slotShow** command does not show that the CP blade is enabled.
- The CP blade does not respond to Telnet commands, or the serial console is not available.
- The **haShow** command indicates an error.
- The calendar clock is inaccurate, or the CP blade does not boot up or shut down normally.
- Any of the following messages display in the error log:
  - "Slot unknown" message relating to a CP slot
  - CP blade errors or I<sup>2</sup>C time-outs
  - FRU: FRU\_FAULTY messages for a CP blade
  - Configuration loader messages or "Sys PCI config" messages
  - Generic system driver messages ("FABSYS")
  - Platform system driver messages ("Platform")
  - EM messages that indicate a problem with a CP blade
  - Function fail messages for the CP master

For more information about diagnostic and error messages, See the *Brocade Fabric OS System Error Message Reference Manual*.

## Recording critical switch information

Back up the switch configuration before you replace a CP blade. Refer to the *Brocade Fabric OS Administrator's Guide* for backup information.

Perform the following steps to record critical switch information:

1. Log into the healthy CP blade as `admin`, using either a Telnet or serial console connection. The default password is `password`.
2. Check the active LED on the CP blades. See Figure 19 on page 41 to determine which one is active.
3. Run the **haShow** command to confirm the active CP blade. See the following example for possible output.

```
swDir:admin> haShow
Local CP (Slot 6, CP1): Active
Remote CP (Slot 5, CP0): Standby, Healthy
HA Enabled, Heartbeat Up, State Synchronized
```

Enter all of the remaining commands from the serial console for the *active* CP blade, unless otherwise indicated. For more information about the commands, see the *Brocade Fabric OS Command Reference Manual*.

4. If the healthy CP blade is also the active CP blade, continue with 6 on page 66, otherwise, fail over the blades as follows:
  - a. Login to the faulty CP blade as `admin`, using either a Telnet or a serial console connection.  
If you connect successfully to the faulty CP continue to step b.  
If you cannot connect to the faulty CP, then you can remove the faulty CP blade for repair as follows:
    - Turn the CP blade off and notify the director of a hot-swap request by sliding the slider switch in the top ejector down to the off position ( **3** in Figure 33 on page 67).
    - Wait until the Active CP LED on the healthy CP blade is lit. You can remove the faulty CP for replacement.
  - b. Enter the **haFailover** command. The healthy CP blade becomes the active CP blade.
  - c. Wait until the Status LED on the healthy CP blade is no longer on (indicating the failover is complete).
  - d. Enter the **haShow** command from the healthy CP blade (the new active CP blade) to verify the failover. See the following example for possible output.

```

Fabric OS (cp1)

cp1 login: admin
Password:
swDir:admin> haShow
Local CP (Slot 6, CP1): Active
Remote CP (Slot 5, CP0): Standby, Healthy
HA enabled, Heartbeat Up, HA State synchronized

swDir:admin> haFailover
Local CP (Slot 6, CP1): Active
Remote CP (Slot 5, CP0): Standby, Healthy
HA enabled, Heartbeat Up, HA State synchronized

Warning: This command is being run on a redundant control
processor(CP) system. If the above status does not indicate
'HA State synchronized', then the CPs are not synchronized
and this operation will cause the active CP to reset. This
will cause disruption to devices attached to both switch 0
and switch 1 and will require that existing telnet sessions
be restarted. To reboot a single logical switch on this
system, use the switchreboot command while logged in to
that logical switch.

Are you sure you want to fail over to the standby CP [y/n]?

swDir:admin> haShow
Local CP (Slot 6, CP1) : Standby, Healthy
Remote CP (Slot 5, CP0) : Active
HA Enabled, Heartbeat Up, HA State Synchronized

```

5. Type **firmwareShow** to record the firmware version of the active CP blade.
6. Run the **haDisable** command from the active CP blade to prevent failover or communication between the CP blades during the replacement.
7. Logged into the active CP, use the **configUpload** command to upload the switch configuration to a specified FTP server. Enter the requested information at the prompts. See the following example for possible output.

```

swDir:admin> configUpload
Protocol (scp or ftp) [ftp]: ftp
Server Name or IP Address [host]: 123.456.78.90
User Name [None]: user
File Name [config.txt]: config.txt
Password: xxxxxxx
upload complete

```

## Removing a CP blade

The director continues to operate while a CP blade is being replaced if the redundant CP blade is active and a failover does not occur (you can prevent failover by entering the **haDisable** command).

**Attention:** Wear an ESD grounding strap when handling a CP blade. The chassis has a grounding connection above the ac power switches and connections.

**Attention:** The core section within the director CP blades provides internal routing bandwidth that is always active on both CP blades. Removing a CP blade might impact user performance, and should not occur until the replacement CP blade is ready to be installed.

To ensure adequate system pressure for cooling purposes, leave the faulty CP blade in the slot until you are ready to perform the replacement procedure.

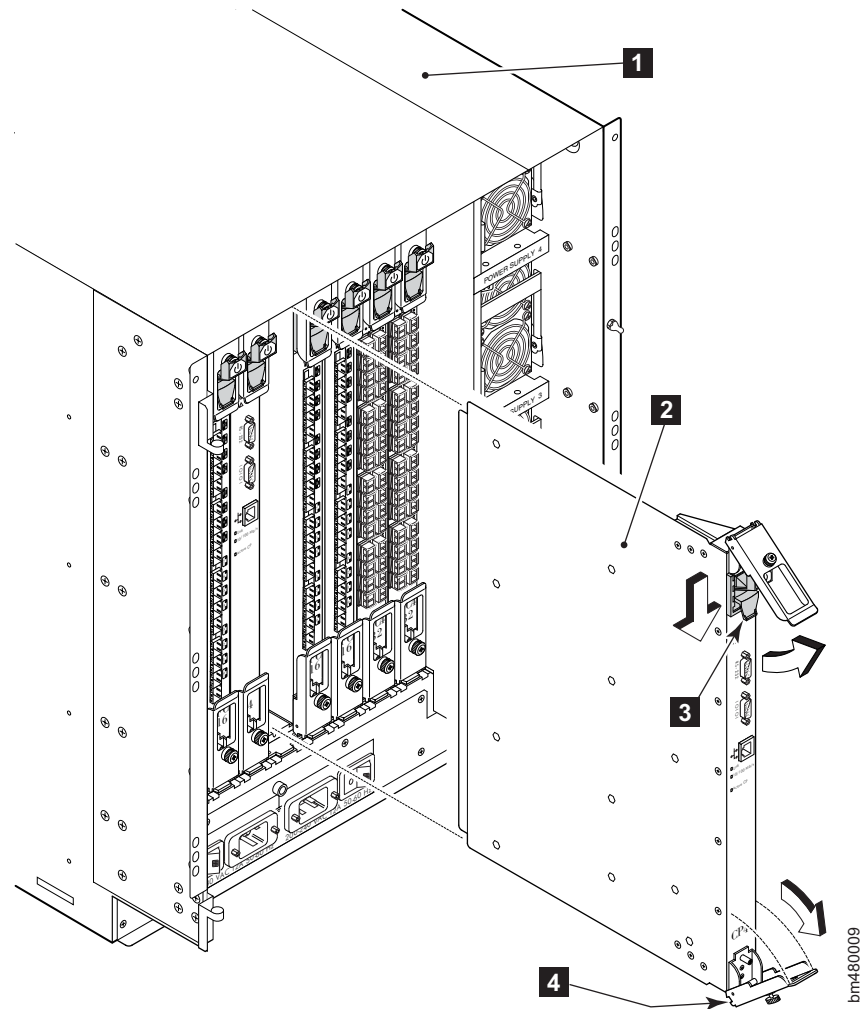

Figure 33. CP blade removal and replacement

- |          |  |
|----------|--|
| <b>1</b> | Director chassis                           |
| <b>2</b> | CP blade                                   |
| <b>3</b> | On/Off slider switch (in the Off position) |
| <b>4</b> | Ejector (x2)                               |

Perform the following to remove a CP blade. See Figure 33.

1. Login to the active CP as the admin user. You can use a serial cable or if you have connected the director to your IP network, you can use Telnet, Web Tools, or Fabric Manger. You can determine which CP is active by using the **haShow** command or by viewing the Active LED on the front of the CP.

2. If the CP you want to replace is the active CP issue the **haFailover** command. Wait until the failover has completed. Use the **haShow** command to verify the CPs are synchronized and the failover is complete.
3. Use the **slotPowerOff** command to disable the standby CP (the CP you want to replace).
4. Wait until the standby CP Power LED has turned off.
5. Disconnect all cables (modem, serial, Ethernet) from the faulty (standby) CP blade.
6. Slide the on/off switch in the top handle down. See **3** in Figure 33 on page 67.
7. Unscrew the captive screw from both ejectors using the Phillips screwdriver.
8. Lever both ejector handles open simultaneously to approximately 45 degrees and pull the CP blade out of the chassis.

## Installing a CP blade

**Attention:** Do not force the installation. If the CP blade does not slide in easily, ensure that it is correctly oriented and aligned in the blade guides before continuing. See Figure 32 on page 62.

To ensure proper cooling, do not route cables in front of the exhaust vent (located at the top on the port side of the chassis).

Use the same version of Fabric OS on both CP blades. Using different versions is not supported and might cause malfunctioning. If the replacement CP blade has a different version of Fabric OS, bring both blades to the same firmware version.

Perform the following steps to install a CP blade in the empty CP blade slot (#5 or #6):

1. Open the ejector handles to approximately 45 degrees. Orient the CP blade so that the handles are towards you and the flat metal side is on the left.
2. Align the flat metal side of the CP blade inside the lower and upper blade guides in the slot. See Figure 32 on page 62. Slide the CP blade into the slot until it is firmly seated.
3. Close the ejectors by pressing the ejector handles in toward the CP blade.
4. Tighten the captive screws inside each ejector handle using a Phillips screwdriver.
5. Turn the CP blade on by sliding the On/Off switch in the upper handle up, covering the captive screw.
6. Verify that the Power LED is green (this can take a few seconds). If not, ensure that the CP blade has power, is firmly seated, and the ejectors are in the locked position.
7. Connect the modem, serial, and Ethernet cables as required, to the new CP blade.

**Attention:** Do not route cables in front of the exhaust vent (located at the top on the port side of the chassis).

The new CP blade automatically assumes the IP address and host name assigned to the slot.

8. Verify the installation by completing the steps in “Verifying the operation of the new CP blade” on page 69.



## Verifying the operation of the new CP blade

Verify that startup and POST are complete on the new CP blade (this will take a minimum of 3 minutes) and that the new CP blades have achieved failover redundancy:

1. Wait until the Status LEDs on both CP blades are not lit.

**Note:** The Status LED on the active CP blade displays amber until the active CP blade is fully operational, and the Status LED on the standby CP blade displays amber until the CP blades have achieved failover redundancy.

2. Log in to the active CP blade as admin.
3. Enable the redundancy feature by entering the **haEnable** command.
4. Verify HA is enabled using the **haShow** command. The command output includes “HA Enabled Heartbeat Up” and “HA-state in sync.”

If HA is not enabled, POST is not complete or the CP blades have not yet achieved redundancy. Wait one or two minutes and re-enter the command, until you can verify that redundancy has been achieved.

5. Enter the **slotShow** command. The command output should show the new CP blade as enabled. See the following example for possible output.

```
swDir:admin> slotShow

Slot  Blade Type  ID   Status
-----
 1     SW BLADE      17   ENABLED
 2     SW BLADE      17   ENABLED
 3     SW BLADE      17   ENABLED
 4     SW BLADE      17   ENABLED
 5     CP BLADE      16   ENABLED
 6     CP BLADE      16   ENABLED
 7     SW BLADE      17   ENABLED
 8     SW BLADE      17   ENABLED
 9     SW BLADE      17   ENABLED
10     SW BLADE      17   ENABLED

swDir:admin>
```

6. Enter the **firmwareShow** command to determine the firmware version. See the following example for possible output.

```
swDir:admin> firmwareShow
Local CP (Slot 6, CP1): Active
    Primary partition:  v5.0.1
    Secondary Partition: v5.0.1
Remote CP (Slot 5, CP0): Standby
    Primary partition:  v5.0.1
    Secondary Partition: v5.0.1

Note: If Local CP and Remote CP have different versions
of firmware, please retry firmwaredownload command.

swDir:admin>
```

7. If the firmware version on the replacement blade does not match that on the active CP blade, bring the replacement blade to the same firmware level as the active blade. Check with IBM for supported versions.

8. Enter **firmwareDownload -s** to download the firmware to only one of the CP blades. Enter all requested information (use default values):

```

swDir:admin> firmwaredownload -s
Server Name or IP Address: 192.168.100.1
User Name: user
File Name: /software/v5.0.1/release.plist
Password: *****
Do Auto-Commit after Reboot [Y]:
Reboot system after download [N]:
Firmwaredownload has started.
2005/03/07-14:59:21, [SULB-1001], 923,, WARNING, IBM SAN256B,
Firmwaredownload command has started.
Start to install packages.....
dir #####
ldconfig #####
glibc #####
bash #####
readline #####
terminfo #####
termcap #####
setup #####

<output truncated>

tz #####
mtracer-tool #####
lkcd #####
sysstat #####
Removing unneeded files, please wait ...
Finished removing unneeded files.

All packages have been downloaded successfully.
Firmwaredownload has completed successfully.
2005/03/07-15:05:56, [SULB-1002], 924,, INFO, IBM SAN256B, Firmwaredownload
command has completed successfully.

```

9. Enter **firmwareDownloadStatus** to verify that the firmware downloaded successfully.
10. Enter **haEnable** to reenale HA on the active CP blade.
11. Enter **reboot**.
12. Verify that the reboot is complete and the CP blades have achieved failover redundancy:
  - a. Wait until the status LEDs on both CP blades are not lit.
  - b. Enter **haShow** and verify that the command output includes “HA Enabled Heartbeat Up”. If not, wait a minute and reenter the command, until you have verified that redundancy is achieved.
13. Type **firmwareShow** to verify that the firmware version has been updated.
14. Pack the failed CP blade in the packaging provided with the new CP blade, to return to IBM, following your local return policy.

## Removing and installing a power supply and filler panel

Use this procedure to remove and replace a power supply. The director can continue to operate during the replacement if at least one power supply continues operating. You need a minimum of two power supplies.

**Note:** You do not need to notify the director of a hot-swap request for a power supply before you remove a power supply. The power supply bays are isolated. Power supply filler panels are not required to ensure correct air flow.

The power supply unit slots are numbered 1 through 4 from bottom to top when facing the port side of the chassis. The power connector on the left provides power to the power supplies in slots 1 and 3, and the power connector on the right provides power to the power supplies in slots 2 and 4. The power connectors and the power supply slots are color-coded to identify which power connectors provide power to which power supply slots. See Figure 34 for power supply and power supply filler panel locations.

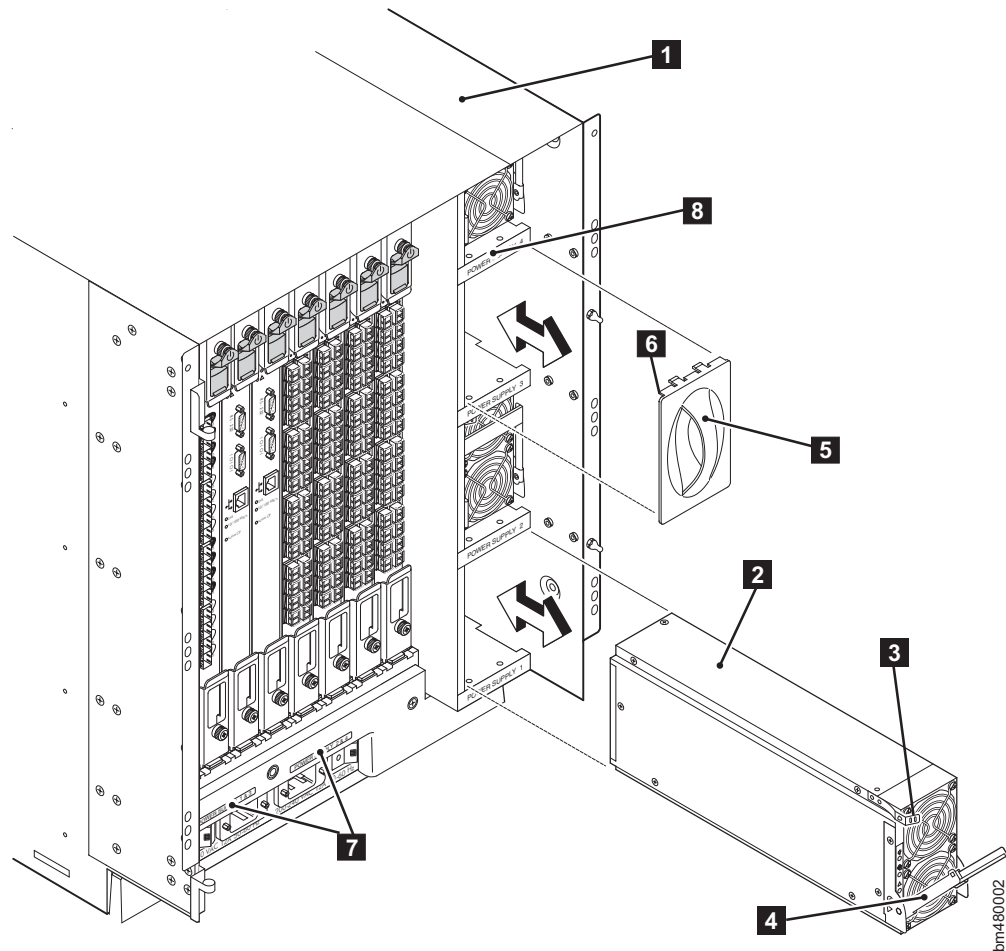

Figure 34. Removing and installing a power supply or filler panel

- 1** Director chassis
- 2** Power supply unit
- 3** Locking tab

- 4** Handle (shown in unlocked position)
- 5** Filler panel
- 6** Filler panel lip
- 7** Ac power connector label (2x)
- 8** Power supply unit label (4x)

For information about how to check the status of hardware components using the CLI, See the *Brocade Fabric OS Administrator's Guide*.

**Attention:** To protect against ac failure, a minimum of one power supply in slot 1 or slot 3 and one power supply in slot 2 or 4 is recommended. Additional power supplies might be required for added redundancy. If only two power supplies are installed and they are both installed in slots corresponding to the same ac power connector cable, unplugging a single ac power cable will power down the entire chassis.



**DANGER**

Hazardous voltage, current, or energy levels are present inside any component that has this label attached. (L001)

**Attention:** There are no user-serviceable parts inside the power supply. Disassembling any part of the power supply voids the part warranty and regulatory certifications.

## Time required

Less than 5 minutes

## Items required

Power supply unit or filler panel

## Removing a power supply

Figure 35 shows the ac power connectors and switches, and identifies the power supplies that each connects to. Use this information in order to maintain power to the director when replacing a power supply, if necessary.

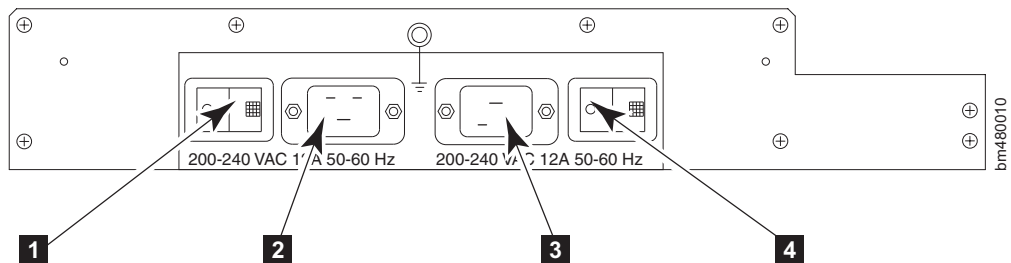

Figure 35. Director ac power connectors and switches

- 1** Ac power switch (controls the power for power supplies 1 and 3)

- 2** Ac power connector (connects to the ac power cables for power supplies 1 and 3)
- 3** Ac power connector (connects to the ac power cables for power supplies 2 and 4)
- 4** Ac power switch (controls the power for power supplies 2 and 4)

Perform the following steps to remove a power supply or filler panel:

1. If the director is not operating during the replacement procedure, skip to step 2. If the director is going to continue operating during the replacement procedure, check the power LEDs to verify that the minimum number of power supply units required is still functioning: A fully populated director requires a minimum of one functioning power supply unit in any slot at all times to ensure power to the director. For maximum availability of the director, you should have a minimum of one power supply unit in slot 1 or 3, and one in slot 2 or 4. See Figure 35 on page 72 to verify which ac power connectors and ac power switches are connected to the unit you will be removing.

If adequate power will not be consistently available, shut down the director gracefully, as follows:

- a. Open a Telnet session to the active CP blade and log in to the switch as `admin`
  - b. Run the **switchShutdown** command.
  - c. Turn off the chassis by flipping both ac power switches to the off position (the 0 on the ac switch).
2. Push the locking tab in toward the power supply, then pull the handle out and down. See Figure 36 on page 74

**Attention:** Support the power supply from underneath while removing it from the chassis.

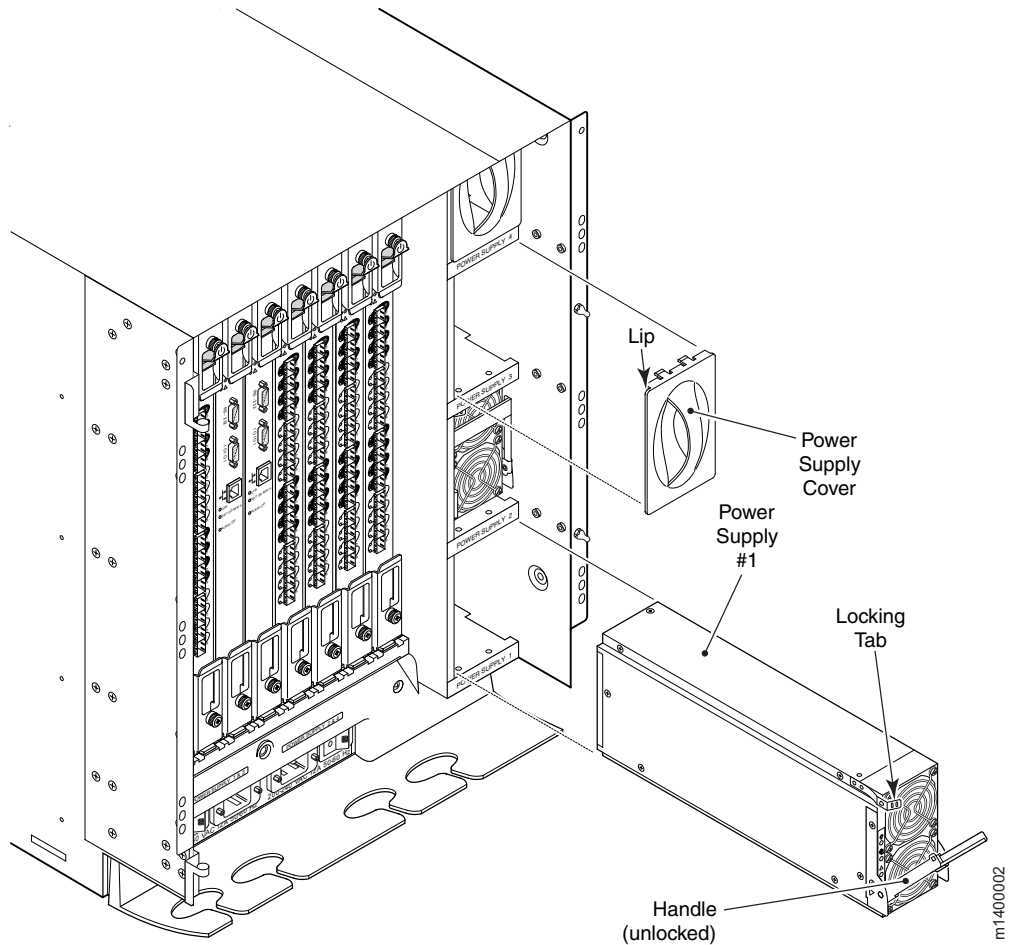

Figure 36. Power supply removal and replacement

3. Use the handle to pull the power supply out of the chassis.

## Removing and installing a filler panel

To remove a power supply filler panel ( **5** in Figure 34 on page 71), use the handle to pull the filler panel straight out from the slot.

To install a power supply filler panel in an empty power supply slot, orient the filler panel so the handle is vertical and the side tabs are on the right; then, push the filler panel into the slot.

## Installing a power supply

**Attention:** Do not force the installation of the power supply. If the part does not install easily, ensure that it is properly oriented.

Ensure that the handle is unlocked; otherwise, damage might occur to the power supply unit and chassis during the installation.

Complete the following steps to install a power supply:

1. Orient the power supply so that the handle is toward the front of the chassis and the LEDs are on the left.
2. Unlock the handle by pressing the locking tab.

3. Insert the unlocked power supply unit completely into the slot and push the handle up until it clicks.
4. Verify that the power supply is seated by pulling gently on the handle.
5. Verify that the power LED on the power supply unit displays a steady green light (see Figure 20 on page 43). If it does not, ensure that both ac power connector cables are plugged in and both ac power switches are flipped to "I" (the ac switch lights up green).

---

## Removing and installing a blower assembly

Use this procedure to replace the blower assembly. The director requires a minimum of two operating blower assemblies at all times. To ensure continuous adequate cooling, maintain three operating blower assemblies at all times except for the brief period when replacing a blower assembly. The port blades automatically shut down if the internal temperature range is exceeded (up to 75° C).

**Attention:** If more than one blower must be turned off at the same time, shut the director down to prevent overheating.



### DANGER

**Hazardous voltage, current, or energy levels are present inside any component that has this label attached. (L001)**

**Attention:** There are no user-serviceable parts inside the blower assembly. Disassembling any part of the blower assembly voids the part warranty and regulatory certifications.

## Time required

Less than 5 minutes

## Item required

Phillips #2 screwdriver  
Replacement blower assembly

## Removing a blower assembly

Perform the following steps to remove a blower assembly:

1. Before removing the blower assembly, verify the other two assemblies are functioning correctly. The blower assembly Power LED should be steady green and the attention/fault LEDs should not be lit. See Figure 37 on page 77 for LED locations. For information about how to check the status of hardware components using the CLI, See the *Brocade Fabric OS Administrator's Guide*.



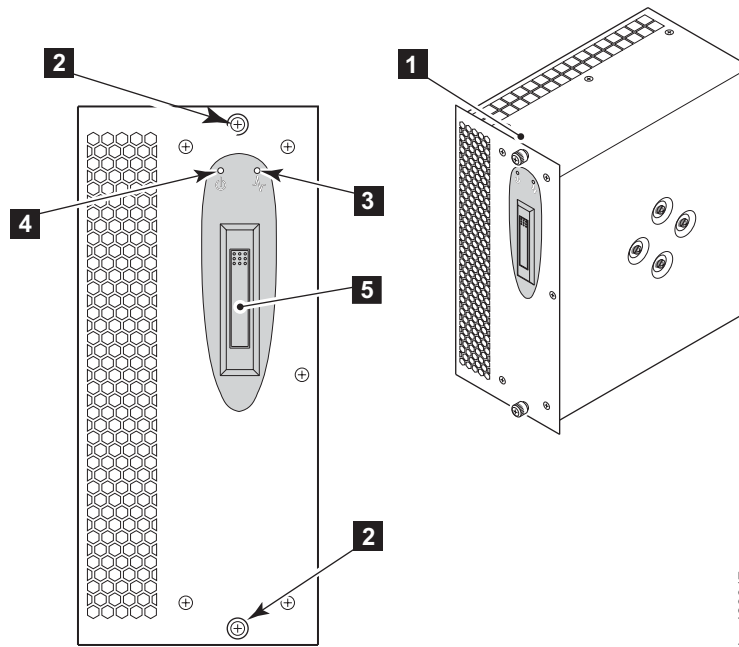

bm480017

Figure 37. Blower assembly LEDs and other parts

- |          |                 |
|----------|-----------------|
| <b>1</b> | Blower assembly |
| <b>2</b> | Captive screw   |
| <b>3</b> | Fault LED       |
| <b>4</b> | Power LED       |
| <b>5</b> | Handle          |

2. Use the screwdriver to loosen the captive screws (**2** in Figure 37) at the top and bottom of the blower assembly.
3. Push in the top of the handle **5**
4. Pull the blower assembly out of the chassis. See Figure 38 on page 78.

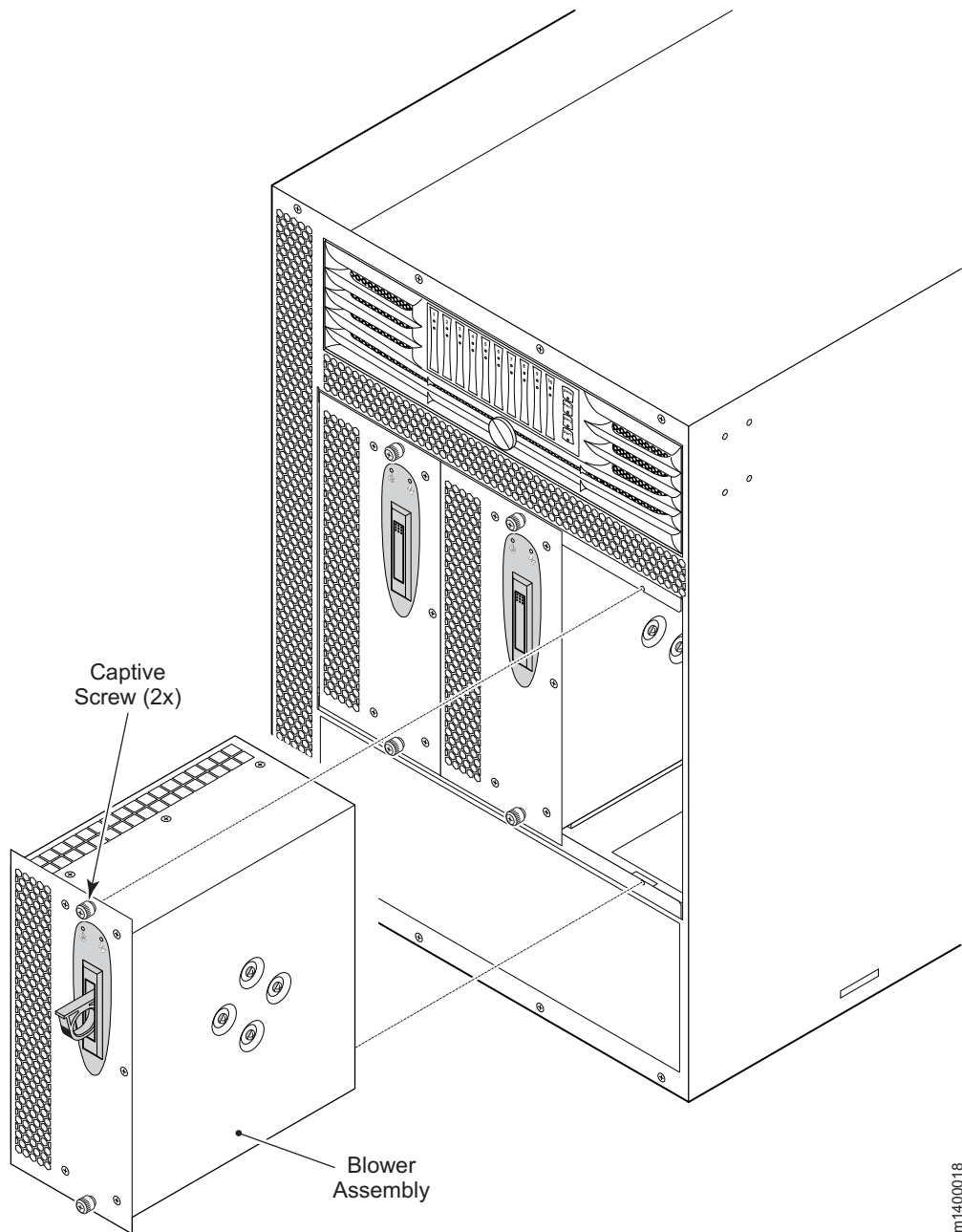

m1400018

Figure 38. Blower assembly removal and installation

## Installing a blower assembly

**Attention:** Do not force the installation. If the blower assembly does not slide in easily, ensure it is properly oriented before continuing with the installation.

Perform the following steps to replace the blower assembly:

1. Orient the blower assembly as shown in Figure 38.
2. Slide it into the chassis, pushing firmly to ensure that it is seated.

3. Verify that the power LED displays a green light; if not, ensure that the blower assembly is correctly seated.
4. Push the top of the handle into the recess.
5. Use a Phillips screwdriver or your fingers to tighten the captive screws.

---

## Replacing the WWN bezel and card

The director World Wide Name (WWN) card is highly reliable and contains fully redundant circuits. The WWN card does not usually require replacement under normal operating conditions.

Before you replace a WWN card, verify that a replacement is necessary by referring to “Verifying if a WWN card needs replacing” on page 80. Contact Technical Support if you have any questions about whether the WWN card requires replacement.

If the WWN card does fail, the director can continue operating until the new WWN card is installed if the configuration is not modified, no hardware components are replaced, and the director is not rebooted.

The WWN card is located on the nonport side of the chassis underneath the WWN bezel. See Figure 39.

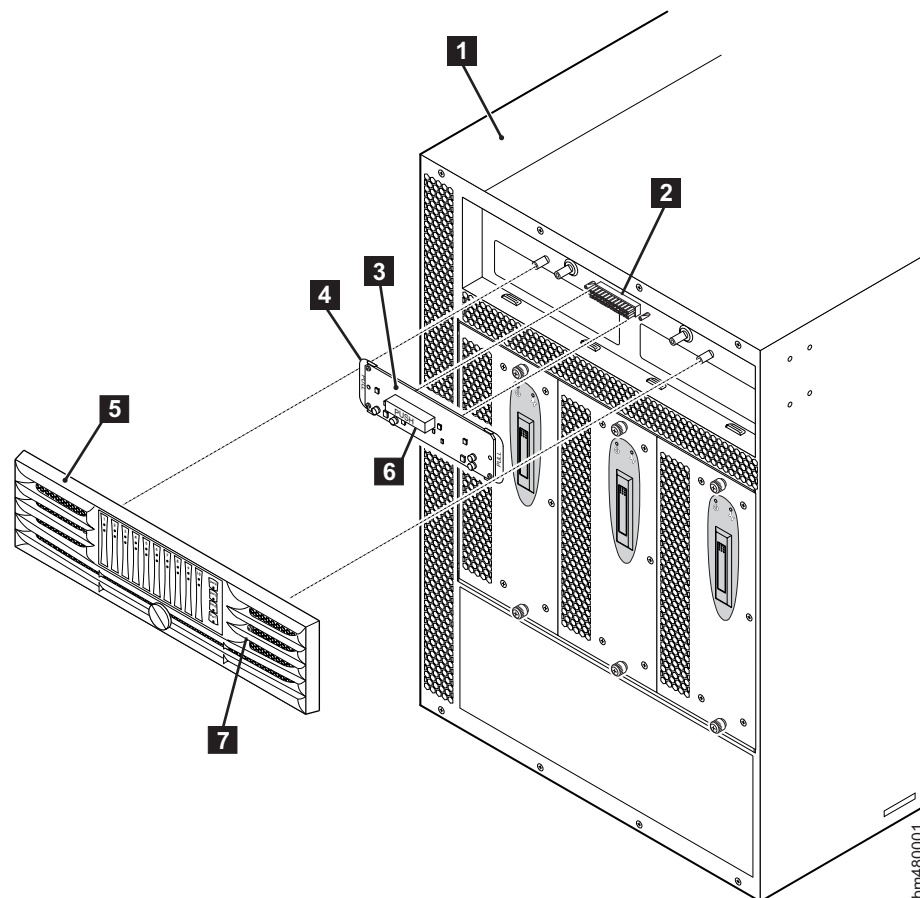

Figure 39. WWN bezel and card removal and replacement

<b>1</b>	Director chassis	<b>5</b>	Bezel
<b>2</b>	WWN connector	<b>6</b>	Push pad
<b>3</b>	WWN card with push pad	<b>7</b>	Captive screw (2x)
<b>4</b>	Handle		

This procedure requires a command line interface (CLI) to the director. The CLI can be either a Telnet session or a serial console session. Instructions are provided here for both.

**Note:** If a serial console is used, all commands must be entered through the active CP blade unless otherwise indicated. For command details, See the *Brocade Fabric OS Command Reference Manual*.

**Attention:** *Do not* power cycle or reboot the director or replace the CP blades or port blades until the WWN card is verified as functional or a replacement WWN card is installed. If any of these events happen while the WWN card is failed or uninstalled, the configuration information is lost. It will be necessary to reconfigure the director after installing the new WWN card.

**Attention:** Disassembling any part of the WWN card voids the part warranty and regulatory certifications. The WWN card contains no user-serviceable parts.

## Time required

Approximately 20 minutes to replace the WWN card.

## Items required

The following items are needed to replace the WWN card:

- ESD (electrostatic discharge) grounding strap
- If a serial console session is used, a serial cable and a workstation computer with a terminal emulator application (such as HyperTerminal for Windows systems or TIP for Solaris systems).

Figure 39 on page 79 shows the nonport side of the director, which contains the WWN bezel and card.

## Verifying if a WWN card needs replacing

Before replacing a WWN card, verify that the replacement is necessary. Ensure that the current card is firmly seated when performing troubleshooting steps. Contact Technical Support if you have any questions about whether the card should be replaced.

Any of the following events might indicate that the card requires replacement:

- Visible mechanical damage to the WWN.
- Any of the Status LEDs on the WWN card not reflecting the actual status of the components. See Figure 22 on page 47
- Problems viewing or modifying the data stored on the WWN card. See Table 13 on page 81.
- Error messages regarding WWN units 1 or 2 See Table 14 on page 81.

To determine the status of the WWN card:

1. Check the LED indicators on the WWN bezel. See Figure 22 on page 47. Verify that the LEDs reflect the actual status of the components. The WWN bezel covers the WWN card and allows its LEDs to shine through. The LEDs on the WWN bezel provide a consolidated view of the port blade status, CP blade status, and power supply status. For information about how to interpret the LED patterns for the different components, see Chapter 4, “Monitoring system components,” on page 37.

**Note:** The LED patterns might temporarily change during POST and other diagnostic tests.

2. Check the WWN card status using the commands listed in Table 13 if you have problems viewing or modifying the data stored on the WWN card. Difficulty retrieving or modifying this data could indicate a WWN card failure.

Table 13. Data Stored on the WWN Card

Data	Related Commands
WWN values	<b>wwn</b> , <b>chassisShow</b>
Data about the chassis and WWN card	<b>chassisShow</b>
Ethernet and fibre channel IP address information for the CP blades	<b>ipAddrShow</b> , <b>ipAddrSet</b>
History log information	<b>historyShow</b> , <b>historyLastShow</b>
Name of switch	<b>switchName</b>

3. If the error log or serial console display error messages that indicate problems with the WWN unit, the WWN card might have failed. See Table 14.

WWN units correspond to information specific to the WWN card and are displayed by the **chassisShow** command.

Table 14. WWN card related system log messages

Type of Message	System Message (errshow or errdump)
WWN unit removal was detected	<timestamp>, [EM-1050], <sequence number>,, INFO, <system-name>, FRU WWN # removal detected.
WWN unit insertion was detected	<timestamp>, [EM-1049], <sequence number>,, INFO, <system-name>, FRU WWN # insertion detected.
WWN unit fails to power on.	<timestamp>, [EM-1004], <sequence number>,, CRITICAL, <system-name>, WWN # failed to power on
WWN unit is being faulted.	<timestamp>, [EM-1034], <sequence number>,, ERROR, <system-name>, WWN # set to faulty, rc=<return code>

## Removing the WWN card

This procedure requires a command line interface (CLI) to the director. The CLI can be either a Telnet session or a serial console session.

**Attention:** *Do not* power cycle or restart the director or replace the CP blades or port blades until the WWN card is verified as functional or a replacement WWN card is installed. If any of these events happen while the WWN card is failed or uninstalled, the configuration information is lost, and it will be necessary to reconfigure the director after installing the new WWN card.

1. Open a CLI session (Telnet or serial) to the director and log in to the active CP as admin. The default password is password.

2. Verify you are logged into the active CP. Run the **haShow** command to determine the active CP.
3. Enter **fruReplace wwn** from the active CP blade and wait for the phrase Do you wish to continue [y/n]? to display, then enter **y**.
4. Wait until the WWN card data is backed up. Do *not* type **continue** until the mechanical replacement is complete. See “Installing a WWN Card.”

```
switch:admin> frureplace wwn
This is the WWN card hot swap interface.
Continuing from this point will require
the whole process to be completed.
If this process is not complete due to a
power cycle, or CP failover, please follow
the recovery procedure in
Core Switch WWN Card Removal and
Replacement document.
Do you wish to continue [y/n]?

Backing up WWN card data, please wait about 25 seconds for further instruction.
Please install the new FRU now.

If this session was lost for any reason, please re-enter the frureplace command and
follow the instructions to complete the operation.

Please enter the word `continue' after the new WWN card has been installed:
```

5. Wait until all the LEDs on the WWN bezel ( **5** in Figure 39 on page 79) turn off.
6. Unscrew both captive screws **7** on the WWN bezel.
7. Pull the bezel away from chassis and set it aside. The WWN **3** card is visible.
 

**Attention:** To protect the WWN card components, wear an ESD grounding strap and prepare an antistatic bag or grounding pad on which to place the WWN card. Do not place anything on top of the card.
8. Use the handles **4** to gently pull the card away from the chassis.
9. Set the WWN card on a static free surface, such as a grounding pad.

## Installing a WWN Card

Complete the following steps to install a new WWN card:

1. Unpack the new WWN card and save the packaging for returning the faulty WWN card.
2. Hold the card by the handles and orient with the LEDs at the top. See Figure 22 on page 47.
3. Align the connector on the card with the connector on the chassis ( **2** in Figure 39 on page 79). The connectors are keyed to ensure correct installation)
4. Use the push pad **6** to press the card onto the connector *gently*, until it is fully seated.
 

**Attention:** Do not force the installation; if the card does not install easily, ensure that it is correctly oriented. The WWN card retains slight freedom of movement after installation.
5. Orient the bezel on the chassis. See **5** in Figure 39 on page 79.
6. Insert both retaining screws **7** into the standoffs on the chassis and tighten to finger-tight.

**Note:** If a serial console session is active, several removal detected and insertion detected messages display on the console as a result of the replacement.

7. In the CLI session, enter **continue** to indicate that the replacement has been completed. See the following example for possible output.

```
Please enter the word `continue' after the new WWN card has been installed:
```

```
continue
```

```
Restoring the information to the replacement FRU now, please wait about 20  
seconds to complete
```

```
Verifying the replacement FRU now...
```

```
WWN card hot swap is now complete.
```

```
FRU replacement completed successfully!
```

8. Verify that the WWN card is correctly connected by checking the LEDs on the WWN card to see if they reflect the status of the components.

**Note:** The LEDs might take up to 2 minutes after WWN card installation to begin functioning.

9. Pack the faulty WWN card in the packaging provided with the new card to return to IBM, following your local return policy.





---

## Chapter 6. Replacing the chassis

The SAN256B chassis is highly reliable and unlikely to fail. This chapter describes how to remove and replace a chassis in the unlikely event of a failure. The director must be removed from the fabric and powered off to perform this procedure. Contact IBM if you have any questions about whether the director chassis requires replacement. This procedure is to be completed only by a qualified IBM service representative.

Refer to the following sections of this chapter for specific information:

- “Verifying necessity of replacement”
- “Preparing for a chassis replacement” on page 86
  - “Time required” on page 86
  - “Items required” on page 86
  - “Recording critical director and SAN information” on page 86
- “Disconnecting the director from the network and fabric” on page 90
- “Removing components from the chassis” on page 90
- “Removing and replacing the chassis” on page 91
- “Installing components into the new chassis” on page 92
- “Reconnecting modems (optional)” on page 93
- “Verifying the correct operation of hardware” on page 93
- “Configuring the new chassis serial number” on page 93
- “Verifying the correct operation of the system” on page 94
- “Reconnecting the system to the network and fabric” on page 95
- “Verifying the correct configuration of the fabric” on page 96

---

### Verifying necessity of replacement

Before replacing the chassis, verify that the replacement is necessary. Ensure that the components are firmly seated when troubleshooting. Contact IBM if you have any questions about whether the chassis should be replaced.

Any of the following events might indicate that the chassis requires replacement:

- Visible mechanical damage to the chassis, including damage to sheet metal or blade guides that prevents correct installation of a component
- Bent or damaged connectors on the main backplane (the surface inside the chassis to which CP blades and port blades connect) or on the blower backplane (the surface to which the blower assemblies connect)
- One or more director components (such as a power supply, blower assembly, port blade, CP blade, or WWN card) do not function properly even after the component is replaced
- An ac power switch shuts off automatically even though all power supplies are removed from the chassis
- The **psShow** or **fanShow** commands continue to show a faulty component even though the component has been replaced
- The **slotShow** command continues to show a faulty CP blade or port blade even though the blade has been replaced

---

## Preparing for a chassis replacement

Use the following information to help prepare for a chassis replacement.

**Attention:** Refer to “Safety and environmental notices” on page xi before performing any removal or installation procedures.

### Time required

The chassis replacement procedure takes approximately 3 hours to complete.

### Items required

The following items are required for the chassis replacement procedure:

- Electrostatic discharge (ESD) grounding strap
- ESD grounding pads for protecting control processor (CP) cards, port cards, and the WWN card
- Serial cable and workstation computer with a terminal emulator application (such as HyperTerminal for Windows systems or TIP for Solaris systems), required only if serial console session used.
- Lifting tool (see “Ordering the lift tool” on page 10)
- A surface to place the old chassis on, such as a second lift or the pallet originally provided with the old chassis
- 1/2 inch socket wrench to remove the pallet bolts
- Torque wrench with #2 Phillips screwdriver tip (if switch is installed in a cabinet)
- #2 slotted screwdriver

## Recording critical director and SAN information

All commands must be entered from a CLI session (Telnet or serial) to the active CP card unless otherwise indicated. For detailed information about Fabric OS commands, refer to the *Brocade Fabric OS Command Reference Manual*. Use a checklist to ensure that all required information is recorded (see “Chassis critical information checklist” on page 89).

To record critical switch and SAN information:

1. Open a Telnet session and login to the director as `admin`. The default password is `password`. Enable the logging function on your Telnet or serial console connection.
2. Back up the current configuration. Type **configUpload** then enter the requested information at the prompts.

**Note:** The **configUpload** command can be entered through a Telnet or serial session, but you must have an Ethernet connection between the director and the server name or IP of the host to complete the upload process. For more information, refer to the **help configUpload** command or the *Brocade Fabric OS Command Reference Manual*.

This command uploads the switch configuration to the customer-defined FTP server, making it available for downloading later, if required.

```
swDir:admin> configupload
Server Name or IP Address [host]: 123.123.123.123
User Name [None]: Admin24
File Name [config.txt]: config-switch0.txt
Password: xxxxxxxx
upload complete
swDir:admin>
```

- Record the director values on a workstation, following steps 4 through 9 below.
- Record the WWN value: Type **wwn**, then copy the command output into a file named "configmiscinfo.txt".

```
swDir:admin> wwn
10:00:00:60:69:00:00:0a
```

- Record the IP address information. Type **ipAddrShow -sw**, then copy the command output into the "config-miscinfo.txt" file.

```
swDir:admin> ipaddrshow

SWITCH
Ethernet IP Address: 10.32.50.12
Ethernet Subnetmask: 255.55.0.0
Fibre Channel IP Address: 1.2.3.4
Fibre Channel Subnetmask: 255.255.255.0

CP0
Ethernet IP Address: 10.32.50.10
Ethernet Subnetmask: 255.55.0.0
HostName : cp0
Gateway Address: 10.32.40.1

CP1
Ethernet IP Address: 10.32.50.11
Ethernet Subnetmask: 255.55.0.0
HostName : cp1
Gateway Address: 10.32.40.1

Backplane IP address of CP0 : 10.0.0.5
Backplane IP address of CP1 : 10.0.0.6
swDir:admin>swDir:admin>
```

- Display and record the manufacturer serial numbers. Type **chassisShow**, then copy the command output into the "config-miscinfo.txt" file.  
"Factory Serial Num" and "Serial Num" are listed under "Chassis/WWN Unit 1."  
If the current WWN card is the original card, the factory serial number listed is the same as the chassis serial number provided on the bar code sticker inside the door of the chassis. If a "Serial Num" value displays, contact IBM to determine whether this serial number should be modified after the new WWN card is installed.

```
swDir:admin> chassisshow

Chassis Backplane Revision: 1F

SW BLADE Slot: 1
Header Version:          2
Power Consume Factor:    -50
Factory Part Num:        60-0001532-03
Factory Serial Num:      KP000000195
Manufacture:             Day: 1 Month: 1 Year: 2004
Update:                  Day: 14 Month: 3 Year: 2005
Time Alive:              187 days
Time Awake:              3 days

<output truncated>

CHASSIS/WWN Unit:        1 (in same assembly as WWN Unit: 2)
Header Version:          2
Power Consume Factor:    -3
Factory Part Num:        60-0001501-07
Factory Serial Num:      FT02X805BE2
Manufacture:             Day: 26 Month: 3 Year: 2004
Update:                  Day: 14 Month: 3 Year: 2005
Time Alive:              207 days
Time Awake:              3 days

<output truncated>

swDir:admin>
```

7. Create a SAN profile by entering and recording the information provided by the following commands:

- **nsShow**
- **nsAllShow**
- **switchShow**
- **fabricShow**

Copy the command output into a text file named "SANbefor.txt". This information can be used after the director is restored to the fabric, to verify that no unintentional changes have occurred to the fabric.

```
swDir:admin> nsshow
Type Pid COS PortName NodeName TTL
<output truncated>

swDir:admin> nsallshow
12 Nx_Ports in the Fabric
<output truncated>

swDir:admin> switchshow
switchName: switch
<output truncated>

swDir:admin> fabricshow
Switch ID Worldwide Name Enet IP Addr FC IP Addr Name
<output truncated>

swDir:admin>
```

- Type **supportShow**, then copy the command output into a text file named "spptshow.txt".

**Note:** The **supportShow** command has very long output and can take several minutes to complete.

This file provides a backup of all the information that might be required by Technical Support. The information can be used after the switch is restored to the fabric, to verify that no unintentional changes have occurred to the fabric.

```
swDir:admin> supportshow
version: 5.0.1
<output truncated>

swDir:admin>
```

- Record the cable connections between the director and the target device and ports. (See "Cable routing tables" on page 97).

## Chassis critical information checklist

Use the table below, or a similar structure to record critical information when replacing a director chassis.

Table 15. Critical information checklist example

Configuration information	
	Location of "config-switch.txt" file:
	Location of "config-miscinfo.txt" file:
	IP address, subnet mask:
	WWN for director:
SAN profile	
	Location of "SANbefor.txt" file:
	Notes regarding <b>nsShow</b> output:
	Notes regarding <b>nsAllShow</b> output:
	Notes regarding <b>switchShow</b> output:
	Notes regarding <b>fabricShow</b> output:
Output from "supportShow" command	
	Location of "spptshow.txt" file:
	Notes regarding <b>supportShow</b> output:
Information about the new chassis	
	New factory serial number:
	New serial number (if available):

**Note:** Copying the individual switch configurations, miscellaneous configuration information, SAN profile, and **supportShow** output into text files is recommended. Recommended file names are "configswitch. txt," "config-miscinfo.txt," "SANbefor.txt," and "spptshow.txt," respectively.

---

## Disconnecting the director from the network and fabric

To disconnect the director from the network and fabric:

1. Shut down the director. Type **switchShutdown** to ensure a graceful shutdown and verify that the command has completed and displayed the message, "Cleaning up kernel modules.....Done."

```
swDir:admin> switchshutdown
Stopping all switch daemons...Done.
Powering off slot 1...Done.
Powering off slot 4...Done.
Checking all slots are powered off...Done.
Cleaning up kernel modules.....Done
```

2. Power off the chassis by flipping both ac power switches to "0" (the LEDs inside the clear plastic ac power switches should turn off). To maintain the ground connection, leave both power cords connected to the chassis and to an electrical outlet.
3. Label the cables connected to the port blades and CP blades, if not already labeled, to indicate how to reconnect them, and record the connections in the "Cable routing tables" on page 97.
4. Disconnect all cables from the port blades and set them aside. The SFP transceivers can be left in the port blades or removed. If you are using any, save the cable management pillars and Velcro cable straps for later use.
5. Disconnect all cables from both CP blades.

---

## Removing components from the chassis

**Attention:** Before removing any components, refer to "Safety and environmental notices" on page xi, and particularly to "Rack safety" on page xviii to ensure that any component removals and installations do not affect the stability of the cabinet.

**Attention:** To prevent damage to the equipment from ESD:

- Ensure that the director is grounded when removing or installing static-sensitive components. This can be accomplished by leaving the power cords attached to the chassis and a power source or by implementing standard ESD precautions, such as placing the chassis on a grounded bench.
- Wear an ESD grounding strap when handling the CP cards, port cards, and WWN card.
- Protect the CP cards, port cards, and WWN card with static bags or grounding pads while they are out of the chassis.

You must remove the field replaceable units (FRUs) from the director chassis in the order listed below. Refer to the instructions in Chapter 5, "Removing and installing components," on page 49 for component-specific removal instructions.

1. Remove the chassis door as described in "Removing and installing the chassis door" on page 49.
2. Remove the power supply units or filler panels as described in "Removing and installing a power supply and filler panel" on page 71.
3. Remove the port blades or filler panels as described in "Removing and installing a port blade or filler panel" on page 57.
4. Remove the CP blade as described in "Removing and installing a CP blade" on page 63.

5. Remove the blower assemble as described in “Removing and installing a blower assembly” on page 76.
6. Remove the WWN bezel and card as described in “Replacing the WWN bezel and card” on page 79.
7. Remove power cords.
8. Remove the cable management tray as described in “Removing and installing the cable management tray” on page 54.

---

## Removing and replacing the chassis

Although the empty chassis is lighter than a fully populated chassis, a lifting device is still required to move it. Refer to Chapter 2, “Installing and removing a SAN256B director,” on page 9 for more detailed instructions on removing a director from a cabinet. The instructions below only provide an outline of the steps required to complete this process.



>47 kg (104 lb.)

**CAUTION:**

**The weight of this part or unit is approximately 47 kg (104 lb). It takes specially-trained persons and/or a lifting device to safely lift this part or unit. (C011)**

**Attention:** Do not place a director chassis directly on the floor. It cannot be easily moved from the floor back onto a lift or pallet.

1. Uninstall the chassis from the cabinet (see Chapter 2, “Installing and removing a SAN256B director,” on page 9 for detailed steps) and place it onto an extra lift or on the shipping pallet originally provided with the chassis. Remove the rack mount hardware, and set the hardware aside for use with the new chassis.
2. Unpack the new chassis:
  - a. Use scissors to cut the two bands that encircle the packaging.
  - b. Lift off the lid and remove the kits and foam from the top of the chassis.
  - c. Lift the cardboard box off the chassis and remove the plastic bag from around the chassis. Save packing materials for use when returning the old chassis.
  - d. Leave chassis attached to pallet if chassis must be transported to the installation location.
3. Transport the new chassis to the installation area, using a pallet jack or the IBM approved lift tool. If a pallet jack is available, place the tines into the gaps under the chassis. Doorways must be wider than 36 inches (91 cm) to accommodate the chassis on the pallet.
4. Remove the pallet brackets and bolts:
  - a. Remove the four bolts holding the chassis to the pallet, using the 1/2 inch socket wrench.
  - b. Remove the four brackets from bottom of the chassis.
  - c. Save the pallet, pallet brackets, and pallet bolts for use when returning the faulty chassis, if required.
5. Install the chassis in the cabinet, using a lift tool to raise the chassis to the correct level. See Chapter 2, “Installing and removing a SAN256B director,” on page 9 for detailed steps.

**Attention:** To ensure adequate cooling, install the chassis with the cable side, which contains the air intake vents, facing the cool air aisle.

---

## Installing components into the new chassis

Install the components into the new director chassis in the order listed below. Refer to Chapter 5, “Removing and installing components,” on page 49 for more specific installation information.

**Attention:** Do not force the installation of any of the components. If the component does not slide in easily, ensure that it is correctly aligned and positioned before continuing.

**Attention:** Do not turn on the power until it is time to verify hardware operation

1. Install the cable management tray on the new chassis, as described in “Installing a cable management tray” on page 56.
2. Verify that both ac power switches are off (set to “0”), then connect power cords and power cord retainers (which should still be on the cords) to the new chassis (see Figure 17 on page 29).
  - a. Connect the power cords to the power connectors on the chassis. The power cords are designed with right and left bends to facilitate cord management. Ensure that the power cord has a minimum service loop of 6 inches available at the connection to the switch and that it is routed so that it is not exposed to stress.
  - b. Tighten the adjusting screw on each retainer until the power cord cannot be pulled out of the retainer. This prevents accidental disconnection from the chassis.
  - c. Connect the power cords to a power source with voltage of 200 to 240 VAC, 50-60 Hz.

**Note:** To protect against ac power failure, a separate power source is recommended for each cord. Routing the power cables out the sides of the chassis is recommended.

**Attention:** Do not turn the ac power switches on until you verify the hardware of the system (see “Verifying the correct operation of hardware” on page 93).

3. Put on an ESD grounding strap and attach it to the grounding strap connector on the chassis ( **4** in Figure 1 on page 3).
4. Install the WWN card and bezel in the new chassis as described in “Installing a WWN Card” on page 82.
5. Install the blower assemblies in the new chassis as described in “Installing a blower assembly” on page 78.
6. Install the CP blades in the new chassis as described in “Installing a CP blade” on page 68.
7. Install the port blades or filler panels in the new chassis as described in “Installing a port blade” on page 61.
8. Install the power supplies or filler panels in the new chassis as described in “Installing a power supply” on page 74.
9. Reinstall the chassis door as described in “Installing the chassis door” on page 50.



---

## Reconnecting modems (optional)

The director detects modems only during power on or reboot. If a modem is connected to an operating switch, a reboot is required for the director to detect the modem. If modems are in use, reconnect the modem cables to the CP cards. For modem installation instructions, see Appendix C, “Setting up and installing the modems,” on page 115.

---

## Verifying the correct operation of hardware

Follow these steps to power on the system and verify that the hardware is operating correctly.

1. Turn on both ac power switches by flipping them to “I”. The LEDs inside the ac power switches light up green when power is being supplied.

By default, the director automatically performs a power-on self-test (POST) each time it is powered on. POST takes a minimum of three minutes and is complete when LED activity returns to standard state.

2. Verify that the director is powered on and POST is complete (all power LED indicators on the port blades and CP blades should be a steady green).
3. Verify that all components are functioning correctly by checking the LEDs for each component. If the LEDs do not indicate a standard healthy state, try reinstalling the corresponding component.

---

## Configuring the new chassis serial number

Configure the new chassis number by completing the following steps.

1. Open a CLI session (Telnet or serial) to the director . Use the IP address of the director through Telnet and log in as root. The root and factory account disclaimer displays.

```
Fabric OS (swDir)
login: root
Password:
Disclaimer for Root and Factory Accounts Usage!

This Fibre Channel switch is equipped with Root and Factory accounts
that are intended for diagnostics and debugging purposes solely by
the Equipment vendor's trained engineers. Improper use of the
functionality made available through the Root or Factory account could
cause significant harm and disruption to the operation of the SAN fabric.

Your use of the functionality made available through the Root or Factory
account is at your sole risk and you assume all liability resulting from
such use. The Equipment vendor shall have no liability for any losses
or damages arising from or relating to the use of the Root or Factory
account (and the functionality enabled thereby) by anyone other than
the Equipment vendor's authorized engineers.

Proceeding with the usage of this switch as the Root or Factory user
explicitly indicates your agreement to the terms of this disclaimer.

swDir:root>
```

2. Change the Factory Serial Number to the serial number of the new chassis (the serial number is provided on the barcode sticker on the port side of the new chassis).

- a. Type **fruInfoSet chassis 1** at the prompt.
- b. Type the IBM serial number, if any, at the "SN:" prompt.
- c. Type the chassis serial number at the "Chassis SN:" prompt.
- d. Verify that the command redisplay the correct serial numbers.

```
swDir:root> fruinfoSet chassis 1
ID: (none) >
PN: (none) >
SN: (none) > IBMssn12345
RV: (none) >
Chassis SN: (none) > FT00X8008A4

New FRU Info for: chassis(wnn) 1
ID: none
PN: none
SN: OEMssn12345
RV: none
Chassis SN: FT00X8008A4
swDir:root>
```

3. Verify that the chassis serial number has been entered correctly by typing **chassisShow** at the prompt.

---

## Verifying the correct operation of the system

To verify that the director is operating correctly, follow the steps below.

1. Log in to the director as admin.

```
swDir:root> login
login: admin
password: xxxxxxxx
swDir:admin>
```

2. Enter **slotShow** and verify that all the installed cards are detected and that their status is operational.

```
swDir:admin> slotshow
Slot  Blade Type  ID      Status
-----
1     SW BLADE      2       ENABLED
2     SW BLADE      2       ENABLED
3     SW BLADE      2       ENABLED
4     SW BLADE      2       DIAG RUNNING POST2
5     CP BLADE      1       ENABLED
6     CP BLADE      1       ENABLED
7     SW BLADE      2       DIAG RUNNING POST1
8     SW BLADE      2       DISABLED
9     SW BLADE      2       INSERTED, NOT POWERED ON
10    UNKNOWN VACANT
swDir:admin>
```

3. Verify that the director is functioning correctly by typing **switchShow**. This command displays switch and port status information.

```

swDir:admin> switchshow
switchName:      swDir
switchType:      42.0
switchState:     Online
switchMode:      Native
switchRole:      Principal
switchDomain:    2
switchId:        fffc02
switchWwn:       10:00:00:60:69:80:5b:e2
zoning:          ON (c3)
switchBeacon:   OFF
blade1 Beacon:  OFF
blade3 Beacon:  OFF
blade9 Beacon:  OFF

Area Slot Port Media Speed State
=====
1 1 0 id N4 Online F-Port 10:00:00:00:c9:29:0e:77
<output truncated>

swDir:admin>

```

4. Verify that all the IP address information is correct by typing **ipAddrShow** and checking the results against the IP information recorded in the "config-miscinfo.txt" file.

```

swDir:admin> ipaddrshow

SWITCH
Ethernet IP Address: 10.32.50.12
Ethernet Subnetmask: 255.55.0.0
Fibre Channel IP Address: 1.2.3.4
Fibre Channel Subnetmask: 255.255.255.0

CP0
Ethernet IP Address: 10.32.50.10
Ethernet Subnetmask: 255.55.0.0
HostName : cp0
Gateway Address: 10.32.40.1

CP1
Ethernet IP Address: 10.32.50.11
Ethernet Subnetmask: 255.55.0.0
HostName : cp1
Gateway Address: 10.32.40.1

Backplane IP address of CP0 : 10.0.0.5
Backplane IP address of CP1 : 10.0.0.6
swDir:admin>swDir:admin>

```

---

## Reconnecting the system to the network and fabric

**Attention:** Refer to "Managing cables" on page 50 for information on how to physically manage the arrangement of the cables within the director chassis, and cautions on handling and routing the cables.

Refer to the cable routing information recorded in "Cable routing tables" on page 97 to ensure the correct cable connections in the steps below.

1. Connect the CP blades to the local area network, one blade at a time.
  - a. Refer to the cable routing information recorded earlier and insert the appropriate Ethernet cables into each Ethernet port.
  - b. Connect the other ends to an Ethernet 10/100 Base-T LAN, if not already connected.

**Note:** The director can be accessed by remote connection using any of the available management tools, such as Telnet or Web Tools. Ensure that the director is not modified from other connections during the rest of this procedure.

2. Reconnect the transceivers and cables to the port blades, as required .
  - a. Install a transceiver into each port, if not already installed (see “Installing and removing SFPs in a port blade” on page 57).
  - b. Select the cable that corresponds to the port and position it so that the key (the ridge on one side of the cable connector) is aligned with the slot in the transceiver. Insert the cable into the transceiver until the latching mechanism clicks.
  - c. Repeat step b for each remaining port on the blade.
  - d. Repeat steps a through c for each of the remaining port blades.
3. Organize the cables as required (see “Managing cables” on page 50).

---

## Verifying the correct configuration of the fabric

Copying the command outputs from this section into a file is recommended. Verify the correct configuration of the fabric by following the steps below.

1. Create an "after" SAN profile by entering the following commands and copying the output to a text file named "SANafter.txt".
  - **nsShow**
  - **nsAllShow**
  - **switchShow**
  - **fabricShow**

```
swDir:admin> nsshow
Type Pid COS PortName NodeName TTL(sec)
N 020f00; 3;10:00:00:01:73:00:29:46;10:00:00:01:73:00:29:46; na
Fabric Port Name: 20:0f:00:60:69:90:03:f0
<output truncated>

swDir:admin> nsallshow
{
020f00 021fda 021fdc 021fe0 021fe1
5 Nx_Ports in the Fabric}

swDir:admin> switchshow
switchName: swDir
<output truncated>

swDir:admin> fabricshow
Switch ID Worldwide Name Enet IP Addr FC IP Addr Name
<output truncated>
swDir:admin>
```

2. Determine any differences between the information in the "SANafter.txt" file and the information in the "SANbefor.txt" file created earlier. In particular, look for differences in the following:
  - Device types
  - Number of devices
  - ISL and port states
  - Number of switches in the fabric
3. Resolve any issues or unintentional changes to the director or fabric.
  - If there are any mechanical problems, try reseating the associated component.
  - If the configuration information is not correct for the director, modify as required. If necessary, the configuration saved before the replacement can be downloaded using the **configDownload** command.

The **configDownload** command can be entered through a Telnet or serial session, but the director must have an Ethernet connection to the server name or IP of the host for the download process to complete. For more information, refer to the **help configdownload** command or the *Brocade Fabric OS Command Reference Manual*.

```
swDir:admin> configdownload
Server Name or IP Address [host]: 123.123.123.123
User Name [None]: Admin24
File Name [config.txt]: config-switch.txt
Password: xxxxxxxx
download complete
swDir:admin>
```

- If other issues exist, contact technical support.
4. If required, package the faulty chassis for return to IBM, following local procedures.

---

## Cable routing tables

Table 16 provides a sample of cable routing information. Create your own table, or use Table 17 on page 98 to record this information, if it is not already available.

*Table 16. Sample cable routing table for SAN256B director (Switch Name: swDir)*

Slot/Port	Cable labels		Device connected to	Slot/Port of device
	Switch end	Device end		
Slot 1 Port 0	North 24 - 1/0	East 26 - 0	SANB32 East 26	0
Slot 5 Serial	North 24 - 5 / Serial	Work 5 - 2	Workstation 5	Com 2
Slot 8 Port 15	North 24 - 8/15	RAID 16 - 4	RAID 16	4

Table 17. Cable routing table for SAN256B director

Slot/Port		Cable labels		Connected device	Slot/Port of device
Slot	Port	Switch end	Device end		
	0				
	1				
	2				
	3				
	4				
	5				
	6				
	7				
	8				
	9				
	10				
	11				
	12				
	13				
	14				
	15				
	16				
	17				
	18				
	19				
	20				
	21				
	22				
	23				
	24				
	25				
	26				
	27				
	28				
	29				
	30				
	31				

## Appendix A. Product specifications

This section provides product specifications for the SAN256B director

### System architecture

Table 18 lists the system architecture for the director.

Table 18. System architecture

Fibre channel ports	256 ports, universal (E, F, and FL) Up to eight port blades (16-port or 32-port)
Control Processor	Redundant (active/standby) control processor modules
Scalability	Full fabric architecture: 239 switches maximum
Performance	1.063 Gbps line speed, full duplex 2.125 Gbps line speed, full duplex 4.25 Gbps line speed, full duplex Autosensing of 1-, 2-, and 4-Gbps port speeds optionally programmable to fixed port speed speed matching between 1-, 2-, and 4-Gbps port speeds
ISL Trunking	Can use up to 8 ports in a trunk group to form a 34 Gbps trunk.
Aggregate bandwidth	2048 Gbps, end-to-end
Switch latency	For the FC4-16 blade: <2.1 microsecond any port to any port at 4 Gbps, cut-through routing, within the same blade For the FC4-32 blade: <3.6 microsecond any port to any port at 4 Gbps, cut-through routing
Maximum frame size	2112-byte payload
Frame buffers	108 per 4-port group, dynamically allocated
Classes of service	Class 2, Class 3, Class F (interswitch frames)
Port types	FL_port, F_port, and E_port; self-discovery based on switch type (U_port); optional port type control
Data traffic types	Fabric switches supporting unicast, multicast (255 groups), and broadcast

Table 18. System architecture (continued)

Media types	<p>Hot-pluggable, industry-standard small form factor pluggable (SFP), LC connector;</p> <ul style="list-style-type: none"> <li>• short-wave laser (SWL), up to 500 m (1,640 ft)</li> <li>• long-wave laser (LWL), up to 10 km (6.2 mi)</li> <li>• extended long-wave laser (ELWL), up to 80 km (49.6 mi)</li> </ul> <p>distance depends on fiber optic cable and port speed</p> <p><b>Note:</b> When operating at 4 Gbps, only SWL is supported.</p>
Fabric services	<p>Simple Name Server; Registered State Change Notification (RSN); Alias Server (multicast); Brocade Advanced Zoning; Web Tools; Fabric Watch; Extended Fabrics; Remote Switch; ISL Trunking; End-to-End Performance Monitoring, FICON CUP</p>

## Physical dimensions

Table 19 lists the system size and weight.

Table 19. System size and weight

System size		Weight	
Width	43.74 cm (17.22 in.)	256-port configuration with eight FC4-32 port blades	98 kg (216 lb) without transceivers
Height	61.24 cm (24.11 inches/14U)	128-port configuration with eight FC4-16 port blades	95 kg (210 lb) without transceivers
Depth	70.90 cm (27.90 inches)	Empty chassis	47 kg (104 lb)
Depth (with door)	74.20 cm (29.20 inches)		

Table 20 lists the FRU weights.

Table 20. FRU weights

FRU	Weight
Chassis (empty)	47 kg (104 lb)
CP4 blade	3.1 kg (6.8 lb)
FC4-16 port blade	2.7 kg (6.0 lb) without transceivers
FC4-32 port blade	3.1 kg (6.8 lb) without transceivers
Filler panel	1.5 kg (3.2 lb)
Power supply	3.2 kg (7.0 lb)
Blower assembly	4.0 kg (8.8 lb)



Table 20. FRU weights (continued)

FRU	Weight
Chassis door	3.5 kg (7.6 lb)
Cable management tray	0.3 kg (0.6 lb)
WWN bezel	0.3 kg (0.6 lb)

## Facility requirements

The facility where the SAN256B is in use must meet the following requirements to provide for correct operation:

- Power requirements for a physical inlet:
  - Input power requirements: 200–240 V ac, 12A, 50–60 Hz
  - Recommended power connector: IEC 320, EN60320 C19–Angled, 16A/250V ac
- Adequate supply circuit, line fusing, and wire size, as specified by the electrical rating on the chassis nameplate
- An air flow of at least 595 cubic meters per hour (350 cubic feet per minute), available in the immediate vicinity of the director
- The power specifications listed in Table 21
- The environmental specifications listed in Table 22 on page 102

## Power specifications

### CAUTION:

**To remove all power from the SAN256B, you must disconnect both power cables.**

The power subsystem is a redundant +48 V dc power distribution system with a provision for up to four 1000-watt, 48V dc bulk power supplies. Bulk power supplies produce the intermediate distribution voltage in the distributed power system.

The power specifications listed in 101 are calculated for fully-loaded systems with two power supplies. A fully-loaded system has eight FC4-32 port blades, two CP blades, and three blower assemblies.

Table 21. Power specifications

Specification	Value
Input voltage	A fully loaded switch requires a maximum of 750 Volt-Amps This results in a main current of 3.2 amps at 240 V ac line voltage or 3.6 amps at 208 V ac line voltage. The rated ac input range is 180 to 264 V ac.
Supported power range	Nominal: 200 to 240 V ac, single phase
Input frequency range	47–63 Hz
Power supplies (each)	Output voltages: 48 V at 20 amps; 12 V at 4 amps Maximum output power: 1000 watts
Ac inrush current	40 amps maximum, peak

Table 21. Power specifications (continued)

Ride through	The supply outputs remain within specified regulation for a minimum of 20 msec after the ac mains are disconnected.
Under voltage protection	The power supply self-protects from any input voltage, static or dynamic, from zero volts to its operating ranges. It recovers to normal operation upon returning to its operating range.

## Environmental requirements

Table 22 lists the environmental operating ranges for the Model M14. The requirements for nonoperating conditions are also provided for acceptable storage and transportation environments.

Table 22. Environmental requirements

Condition	Acceptable range during operation	Acceptable range during nonoperation
Ambient temperature	10° to 40° C outside switch (50° to 104° F)	-40° to +70° C outside switch (-40° to 158° F)
Humidity	20%—85% RH noncondensing, at 40° C (104° F), with a maximum gradient of 10% per hour	10% to 93% RH noncondensing, at 70° C (158° F)
Altitude	Up to 3 km (10,000 ft) above sea level	0—12 km (40,000 ft.) above sea level
Shock	20G, 11 MS duration, half-sine wave	33G, 11 MS duration, half-sine wave
Vibration	1G p-p, 5–500 Hz at 1.0 octave per minute	2.4G p-p, 5–500 Hz at 1.0 octave per minute
Air flow	595 cu. meter per hr (350 cu. ft. per min.)	None required.
Heat dissipation	913 Watts or 3115 BTU (Eight FC4-32 blades and two CP4 blades) 711 Watts or 2426 BTU (Eight FC4-16 blades and two CP4 blades)	Not applicable.

**Note:** The 10° to 40° C range applies to the ambient air temperature at the air intake vents on the nonport side of the switch. The temperature inside the switch can be up to 75° C during switch operation. If the internal temperature range exceeds the operating ranges of the components, the LEDs, error messages, and Fabric Watch alerts will indicate a problem. Use the **tempShow** command or Fabric Watch commands to view temperature status.

## Thermal policy

At 32° C or lower, fans operate at a low speed. When the chassis temperature reaches 33° C, fan speed increases to high. If any blade within the chassis reaches 75° C, the fan speed increases to high. If any blade reaches 80° C, the blade is powered down.

---

## Data transmission ranges

Table 23 provides the data transmission ranges for different cable types and port speeds.

Table 23. Data transmission ranges by cable type and port speed

Port speed	Cable size (microns)	Short wavelength	Long wavelength	Extended long wavelength
1 Gbps	50	500 meters (1,640 ft)	N/A	N/A
	62.5	300 meters (984 ft)	N/A	N/A
	9	N/A	10 km (6.2 miles)	80 km (49.7 miles)
2 Gbps	50	500 meters (1641 ft)	N/A	N/A
	62.5	300 meters (984 ft)	N/A	N/A
	9	N/A	10 km (6.2 mi.) without an Extended Fabrics license; 50–100 km with an Extended Fabrics license	80 km (49.7 miles)
4 Gbps	50	152.4 meters (500 ft)	N/A	N/A
	62.5	91.44 meters (300 ft)	N/A	N/A
	9	N/A	N/A	N/A

---

## Fibre channel port specifications

The fibre channel ports in the director support full duplex link speeds at 4.25, 2.125 or 1.0625 Gbs inbound and outbound, automatically negotiating to the highest common speed of all devices connected to the port. Each port has a SerDes (serializer/deserializer) that accepts 10-bit wide parallel data and serializes it into a high-speed serial stream. The parallel data is expected to be "8B/10B" encoded data or equivalent. The ports are compatible with optical SWL (short wavelength: 780-850 nm), optical LWL (long wavelength: 1270-1350 nm), and Extended Long Wavelength (ELWL) laser transmitter SFPs (small form factor pluggable media) and SFP-compatible cables. The strength of the signal is determined by the type of SFP in use. The ports are universal and self-configuring, capable of becoming F\_Ports (fabric ports), FL\_Ports (fabric loop enabled), or E\_Ports (expansion ports).

---

## CP blade specifications

This section describes the specifications for the CP blade.

### Memory specifications

Each CP blade has the following memory:

- Main memory: 512 MB SDRAM (72 bits wide)
- Flash memory
  - User flash: 16 MB of 16-bit wide memory, stored in two 8-MB banks
  - Compact flash: 1 GB, partitioned in two 512-MB sections
- Boot flash: 512 KB of 8-bit memory for system boot

The centralized memory maximizes the overall switch throughput by guaranteeing full transmit and receive bandwidth to all fibre channel ports at all times.

### Battery specifications

The CP blade has a lithium carbon-monoflouride coin cell battery type Rayovac BR1225, specification 3.0 volt, 50 mAh.



**CAUTION:**

**The battery contains lithium. To avoid possible explosion, do not burn or charge the battery.**

*Do Not:*

- **Throw or immerse into water**
- **Heat to more than 100°C (212°F)**
- **Repair or disassemble**

**Exchange only with the IBM-approved part. Recycle or discard the battery as instructed by local regulations. In the United States, IBM has a process for the collection of this battery. For information, call 1-800-426-4333. Have the IBM part number for the battery unit available when you call. (C003)**

---

## Terminal serial port specifications

Each CP blade provides a three-wire terminal serial port (labeled 10101) that has a DB-9 male connector and an RS-232 signal subset.

**Note:** To provide dust and ESD protection, keep the cover on the serial port whenever the port is not in use. The terminal serial port is intended primarily for use during the initial setting of the IP address and for service purposes.

The terminal serial port can be used to connect to a computer workstation or terminal without connecting to the fabric. The terminal device should be configured to 9600 baud, 8 data bits, no parity, 1 stop bit, with no flow control.

A 10 ft. (3.0 m) serial cable is provided with the switch; it can be converted from a DB-9 serial cable to an RJ-45 style serial cable by removing the adapter on the end of the cable.

The terminal serial port requires a straight-through serial cable with a female 9-pin subminiature-D connector. Use the pinouts listed in Table 24 on page 105.

Table 24. Terminal serial port pinouts

Pin	Signal	Description
1	---	---
2	TxDATA	Transmit data
3	RxDATA	Receive data
4	---	---
5	GND	Logic ground
6	---	---
7	---	---
8	---	---
9	---	---

## Modem serial port specifications

Each CP blade has a modem serial port (labeled RS-232) with a fully RS-232 compliant DB-9 connector. See Figure 19 on page 41 for the location of the port.

**Note:** For dust and electrostatic discharge (ESD) protection, keep the cover on the serial port whenever the port is not in use.

The modem port can be used for attaching a modem to each CP blade. The director detects modems only during the power-on or reboot sequences, and automatically initializes them for operation. If modems are connected to an operating switch, a power on/off cycle, restart, or fast restart is required to detect the modems.

If both modems are connected to the telephone line by a “Y” cable, the active CP blade answers on the first ring; if the active CP blade fails to answer, the standby CP blade answers on the seventh ring.

Table 25 lists the pinouts for the modem serial port.

Table 25. Terminal serial port pinouts

Pin	Signal	Description
1	DCD	Data Carrier Detect
2	RxDATA	Receive Data
3	TxDATA	Transmit Data
4	DTR	Data Term Ready
5	GND	Logic ground
6	DSR	Data Set Ready
7	RTS	Request to Send
8	CTS	Clear to Send
9	RI	Ring Indicator

## Power cords

Figure 40 shows the power cords for the country or region listed in Table 26.

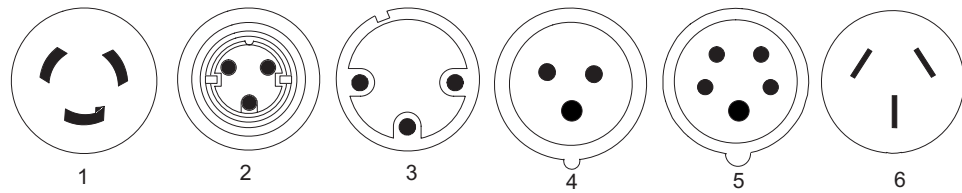

mlt\_sj000675

Figure 40. Power cords

Table 26. Power cord part numbers by country or region

Index number	FRU part number	Units per assembly	Country or region
1	11F0113	1	U.S. Standard, type 12 plug, L6-30P twist-lock connector, 14 ft cord  30 A, single phase  U.S.A., Canada  Anguilla, Antigua, Cape Verde Islands, Cayman Islands, French Polynesia, Honduras, Montserrat, St. Kitts and Nevis, Tortola
1	11F0114	1	U.S., Chicago, type 12 plug, L6-30P twist-lock connector, 6 ft cord  30 A, single phase  Chicago, Illinois, U.S.A.

Table 26. Power cord part numbers by country or region (continued)

1	11F0115	1	AFE, type 12 plug, L6–30P twist-lock connector, 14 ft cord  30 A, single phase  Argentina, Bahamas, Bangladesh, Barbados, Bermuda, Bolivia, Chile, China, Colombia, Costa Rica, Dominican Republic, Ecuador, El Salvador, Guatemala, Guyana, Honduras, Hong Kong S.A.R. of China, India, Indonesia, Jamaica, Japan, Macau S.A.R. of China, Malaysia, Mexico, Myanmar, Netherlands Antilles, Panama, Peru, Philippines, Singapore, Sri Lanka, Suriname, Taiwan, Thailand, Trinidad, Venezuela
N/A	18P2257	1	Universal without wall plug connector (non-US or Canada)
3	11F0106	1	30 A, single phase, PDL connector  Wilco WP, type PDL plug, 14 ft cord  Australia
3	11F0107	1	30 A, single phase, PDL connector  Wilco WP, type PDL plug, right angle, 14 ft cord  New Zealand

Table 26. Power cord part numbers by country or region (continued)

4	31F4466	1	<p>32 A, single phase, three pin connector</p> <p>IEC 309, type 46 connector (2 power + ground), 14 ft cord</p> <p>Belgium, Bahrain, Botswana, Brazil, Egypt, Ethiopia, France, Ghana, Germany, Greece, Iceland, Iraq, Ireland, Italy, Jordan, Kenya, Kuwait, Lebanon, Malawi, Nigeria, Norway, Oman, Qatar, Saudi Arabia, Spain, Sudan, Tanzania, Uganda, United Kingdom, United Arab Emirates, Zaire, Zambia, Zimbabwe</p>
N/A (See Note)	18P2257	1	Switzerland
6	87G6067	1	<p>30 A, single phase</p> <p>Type KP connector, right angle, 14 ft cord</p> <p>Korea</p>
<p><b>Note:</b> Install according to the national electrical code of the specific country or region.</p>			



---

## Appendix B. Diagnostics and troubleshooting

For information about troubleshooting the entire fabric, refer to the *Brocade Fabric OS Administrator's Guide*.

The SAN256B includes a number of diagnostic tools to assist with troubleshooting, including LEDs on the hardware, commands that display current status, diagnostic tests for hardware and software, and error messages. In addition, a number of managing and monitoring features are available, such as Fabric Manager, Web Tools, Fabric Watch, and Advanced Performance Monitoring.

If the director does not operate as expected, the following steps can be taken to diagnose the problem:

- Check the LEDs and refer to the LED tables (see Chapter 4, “Monitoring system components,” on page 37) for interpretation and recommended actions.
- Review the results of the last POST run by the director (see “Interpreting POST and boot results” on page 110).
- Review the error logs (refer to the *Brocade Fabric OS System Error Messages Reference Manual* and the *Brocade Fabric OS Administrator's Guide* for more information).
- Enter the **sensorShow** command to determine the status of the hardware components.
- Run diagnostic tests (see “Diagnostics” on page 111).
- Reboot the director or power the entire chassis off and then back on.

If the problem is still unresolved after these steps, contact technical support. The information required by technical support in order to provide assistance is listed under “Getting help” on page xxiv

This appendix provides the following information:

- “Obtaining chassis and component status”
- “Interpreting POST and boot results” on page 110
- “Diagnostics” on page 111
- “Troubleshooting” on page 112

---

### Obtaining chassis and component status

The CLI commands listed in Table 27 on page 110 provide status and environmental information about the chassis and its components. These commands provide information only, and they do not interrupt traffic flow. For more information about these commands, refer to the *Brocade Fabric OS Command Reference Manual*.

Table 27. Environmental status and maintenance commands

Command	Information Displayed
<b>sensorShow</b>	<ul style="list-style-type: none"> <li>• Temperature readings for the port blades</li> <li>• Temperature readings for the CP blades</li> <li>• Status and RPM of all operational fans</li> <li>• Status of all operational power supplies</li> </ul>
<b>tempShow</b>	<ul style="list-style-type: none"> <li>• Temperature readings for the port blades</li> <li>• Temperature readings for the CP blades</li> </ul>
<b>psShow</b>	Status of all operational power supplies
<b>fanShow</b>	Status and RPM of all operational fans
<b>chassisShow</b>	Serial number, time awake, and additional information about each component
<b>slotShow</b>	Slot occupancy
<b>errShow</b> <b>errDump</b>	Switch error log. Refer to the <i>Brocade Fabric OS System Error Messages Reference Manual</i> for more information on the messages in this log.

---

## Interpreting POST and boot results

The director performs power on self test (POST) by default each time the chassis is powered on or the director is rebooted or reset. The director can be rebooted using the **switchReboot**, **reboot** (to reboot each CP individually), or **fastBoot** commands. The **fastBoot** command reboots the director without running POST. If the active CP blade is rebooted, it fails over to the standby CP blade.

## POST

Each time the director is powered on or reset, the director automatically performs POST, a system check during which LED patterns might vary.

To verify that POST has completed without error:

- Verify that all LEDs return to a normal state after POST completes (see Chapter 4, “Monitoring system components,” on page 37).  
If one or more LEDs do not return to a normal state, and this is not due to the director being set to beacon, refer to the relevant LED table to identify and correct the problem. For port blades and CP blades, the **slotShow** command can be used to check the status of the slots. For information about turning beaconing on/off, refer to the *Brocade Fabric OS Administrator’s Guide*.
- Verify that the switch prompt displays when POST completes.  
If it does not display, POST was not successfully completed. Contact IBM for support.
- Review the system error log using the **errShow** or **errDump** commands.
- Any errors detected during POST are written to the system log, which is accessible through the **errShow** command. For information about error messages, refer to the *Brocade Fabric OS System Error Message Reference Manual*.

POST includes the following steps:

1. Preliminary POST diagnostics are run.
2. Operating system is initialized.

3. Hardware is initialized.
4. Diagnostic tests are run on several functions, including circuitry, port functionality, ability to send and receive frames, all aspects of memory, parity, statistics counters, and serialization.

## Boot

In addition to POST, boot includes the following steps after POST is complete:

1. Universal port configuration is performed.
2. Links are initialized.
3. Fabric is analyzed. If any ports are connected to other switches, the director participates in a fabric configuration.
4. The director obtains a domain ID and assigns port addresses.
5. Unicast routing tables are constructed.
6. Normal port operation is enabled.

---

## Diagnostics

Diagnostic tests are automatically run during POST to check the status of the director. Any error messages generated during POST are sent to the error logs and to the serial console, if connected.

Diagnostic tests can also be run manually to test and troubleshoot the hardware and the firmware, including internal connections and circuitry, transceivers, and port cables. However, diagnostic tests are generally intended for use by support personnel.

**Note:** Diagnostic error messages do not necessarily indicate that the director requires maintenance.

Each diagnostic test can be implemented by entering the related command through a Telnet or serial session. For a list of diagnostic tests and commands, refer to the *Brocade Fabric OS Administrator's Guide*.

All diagnostic tests are run at link speeds of both 1 and 2 Gb/sec. They might temporarily lock the transmit and receive speeds to a specific speed. Some diagnostic tests require interconnecting the ports to each other or using loopback plugs. If ports are interconnected, the media (cables and transceivers) at each end of the connection must be of the same type. For example, short wavelength media must be connected to short wavelength media, and likewise with long wavelength media and copper media.

For more information about diagnostic tests and how to run them, refer to the *Brocade Fabric OS Administrator's Guide* and the *Brocade Fabric OS Command Reference Manual*. For information about diagnostic error messages (**errShow** or **errDump**), refer to the *Brocade Fabric OS System Error Message Reference Manual*.

## Troubleshooting

Table 28 provides a list of issues, possible causes, and recommended actions.

Table 28. Troubleshooting the director

Issue	Possible Cause	Recommended Action
Entire chassis powers off automatically.	Power supplies are inadequate to support the installed components.	Add an additional power supply.
Several or all components are not operating.	One or both power cables may not be connected to a live source.	Ensure that both power cables are connected to live outlets.
	One or both ac power switches might be off.	Ensure that both ac power switches are on (ac switches light up green when on).
Serial connection is faulty or serial port logs have incorrect or missing information.	Serial cable is not connected correctly.	Ensure that the cable is firmly connected to workstation computer and to the director.
	Terminal emulator application parameters are not set correctly.	Ensure that the terminal emulator application is configured as follows: 9600 bits per second, 8 databits, no parity, 1 stop bit, no flow control.
	Serial port might be incompatible (only RS-232 is supported).	Ensure that the director is connected to an RS-232 port. RS-423 serial ports might experience difficulties due to corner-case incompatibilities of the standards.
	Pins on the serial cable or serial port might be damaged.	Remove the cable and inspect the pins on the cable and in the serial port. Do not reinstall if the pins on either component have any visible damage, as this could damage the pins on the other component. Replace components as required.
Modems are not detected by director.	Modems were connected after the director was powered on.	Reboot the CP blade(s) to which the modem(s) are connected.
	Modems are connected to the wrong ports on the CP blades.	Ensure that the modem cables are connected to the ports labeled "RS232" (the serial ports intended for terminal use are labeled 10101).
	Modems are not correctly configured.	Verify that the modems are configured as specified in Appendix C, "Setting up and installing the modems," on page 115.
	Pins on the modem cable or modem port might be damaged.	Remove the cable and inspect the pins on the cable and in the port. Do not reinstall if the pins on either component have any visible damage, as this could damage the pins on the other component. Replace components as required.

Table 28. Troubleshooting the director (continued)

Ethernet link speed is different than expected or a link cannot be established.	There might be a conflict with the Ethernet link speed negotiation set up by the network.	Specify the Ethernet link speed by entering the <b>ifModeSet</b> command.
Configuration data is inaccurate or cannot be accessed.	Chassis was powered off/on while the WWN card was uninstalled or failed.	Install an operational WWN card and power the system off/on again.
	The director was rebooted while the WWN card was uninstalled or failed.	
Initial set up results in IP address/Domain ID conflict.	The director was connected to the fabric before being configured.	Refer to Chapter 3, "Starting and configuring the director," on page 27 and the <i>Brocade Fabric OS Administrator's Guide</i> for configuration information.
LEDs on one or more components are changing rapidly or do not indicate a healthy state.	The director might be booting or running POST.	Verify that boot and POST are complete. The director requires a minimum of 3 minutes, usually, after power-on to complete POST.
	Beaconing might be on for the entire director or for individual components.	Determine whether beaconing is on by entering the <b>switchShow</b> command and determine whether switch beaconing or blade beaconing are on.
	Individual components might have failed.	Refer to the LED tables in Chapter 4, "Monitoring system components," on page 37 for interpretation and recommended actions.
	Pins on the components might be damaged.	Remove component from chassis and inspect pins on component and inside chassis. Do not reinstall if pins on either component are visibly damaged, as this could damage pins on other component. Replace parts as required.
None of the LEDs on an individual component are on.	Component might not be seated correctly.	Ensure that the director has power and component is firmly seated. If problem continues, run the <b>sensorShow</b> command to determine component status. If component is a CP blade or port blade, enter the <b>slotShow</b> command to determine status.
	Component might have failed.	Replace component as necessary.

Table 28. Troubleshooting the director (continued)

CP blades are failing over frequently.	A third-party application has a memory leak.	Check application for memory leaks.
	There is excessive serial port activity.	Ensure that serial port activity remains below specified amount.
	CP blade is attached to an Ethernet with high traffic loads.	Ensure that Ethernet traffic remains below specified amount.
	Chassis is overheated.	Enter <b>sensorShow</b> command to check internal temperature. If components are overheating, shut down port blades as necessary to return the temperature to operating range.
One or more port blades have either shut down or failed POST as indicated by the error log.	Port blades might be overheated.	Enter the <b>sensorShow</b> command to check the internal temperature readings. If components are overheating, shut down port blades as necessary to return the temperature readings to the operating ranges.
	Port blade might be faulty.	Enter the <b>slotShow</b> command to determine status. For more information, enter the <b>diagDisablePost</b> command; then, the <b>slotPowerOff [slot number]</b> and <b>slotPowerOn [slot number]</b> command. Resolve the source of the problem or replace the blade as required.
	Pins on the blade or on the backplane (inside the slot) might be damaged.	Remove blade from chassis and inspect pins on blade and on backplane inside slot. Do not reinstall if pins on either component are visibly damaged, as this could damage pins on other component. Replace components as required.
An individual component is not operating as expected.	Component may not have power or may not be firmly seated.	Ensure component is receiving power (power LED should be on) and component is firmly seated.
	Pins on the component or the backplane might be damaged.	Remove component from chassis and inspect pins on blade and inside chassis. Do not reinstall if pins on either component are visibly damaged, as this could damage pins on other component. Replace parts as required.
	The component might have failed.	Enter the <b>sensorShow</b> command to determine component status. If component is a CP blade or port blade, enter the <b>slotShow</b> command to determine status. Replace component as necessary

---

## Appendix C. Setting up and installing the modems

Each CP blade in the SAN256B contains a modem serial port for connection to a Hayes-compatible modem. The modem serial ports are wired as standard DTE ports and have the same commands, log in capabilities, and operational behavior as the terminal serial ports. However, asynchronous informational messages and other unsolicited text are not sent to the modem ports. No additional software is required to use modems with the director.

**Note:** The director detects modems only during power-on, reboot, or a CP blade failover sequence. Setting up the modems before powering on the director is recommended.

For increased security, any active modem sessions are automatically disconnected if the modem cable is disconnected.

For optimal security, disconnect the modem cable when it is not in use.

---

### Using high availability connectivity

High availability of the modem connection can be ensured by connecting a separate modem to each CP blade and then connecting both modems to a shared telephone line (see Figure 41 on page 116). This ensures an available telephone connection to the active CP blade even if a failover occurs; however, it is necessary to log back in after a failover. When both CP blades are connected to a shared telephone line, callers are automatically dialed in to the active CP blade, which answers on the first ring. If the active CP blade cannot answer for any reason, the standby CP blade answers on the seventh ring and allows login to proceed.

**Note:** If a modem connection is set up, connect a modem to each CP blade. See Figure 41 on page 116

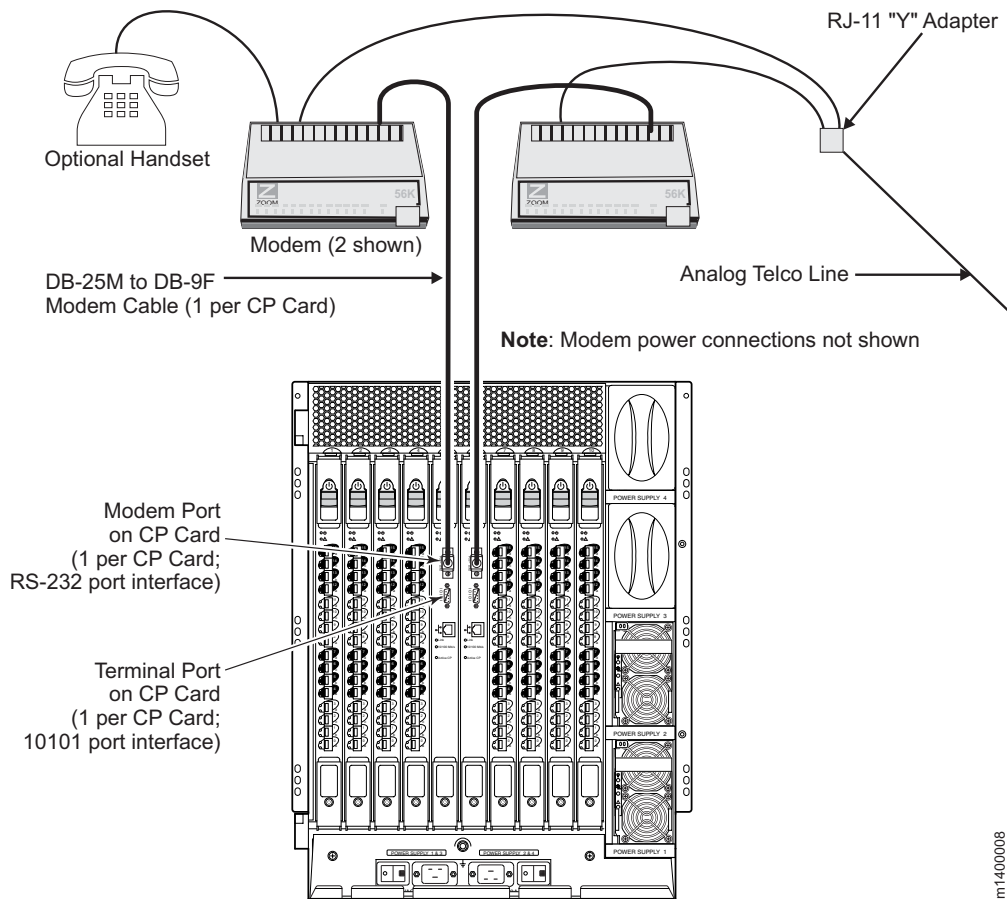

Figure 41. Two modems attached for high availability

## Connecting modems

**Note:** Set up the modems before powering on the director and connect it to the fabric.

The following items are required to set up two modems to work with the director:

- Two Hayes-compatible modems, such as the Zoom/Modem V.92 EXT Model 3049
- Two standard modem cables, DB25 (male) to DB9 (female)
- One RJ-11 "Y" adapter for standard Telco wiring or equivalent circuitry (three total connections)
- One analog telephone line

**Attention:** Power off the director before connecting cables to the modem ports.

Complete the following steps to connect the modems to the director:

1. Optionally power off the director.
2. Set up the two modem units and corresponding power connections, but do not power on the modems until all cables are attached.



3. Connect the modem cables to the modems and to the director RS-232 modem ports. See Figure 41 on page 116.
4. Connect the telephone line inputs on the modems to the RJ-11 "Y" connector. This effectively places both modems on a single telephone line.
5. Optionally connect a telephone handset to one of the "phone" connections on the modems. See Figure 41 on page 116.
6. Connect the "Y" adapter to an appropriate analog telephone line and document the dial-in number for later use.
7. Power on the modems and verify that the Modem Ready indicator illuminates on both units.
8. Power on the director, or restart if it was not powered off in step 1 on page 116. This allows the director to recognize the modems.

---

## Setting up a remote modem system

After the modems are connected, you can use a Telco system to dial in to the modems and verify that they answer and communicate as expected. If a dial-out modem facility is not available, you can use a terminal emulation program on a computer workstation (or laptop) that has an attached modem.

This procedure is only required if a dial-out modem facility is not already available for testing the director modem connections.

Perform the following to set up the optional remote modem:

1. Connect the remote modem to the workstation, as shown in Figure 42.
2. Disable any serial communication programs running on the workstation (such as a synchronization program for a PDA).

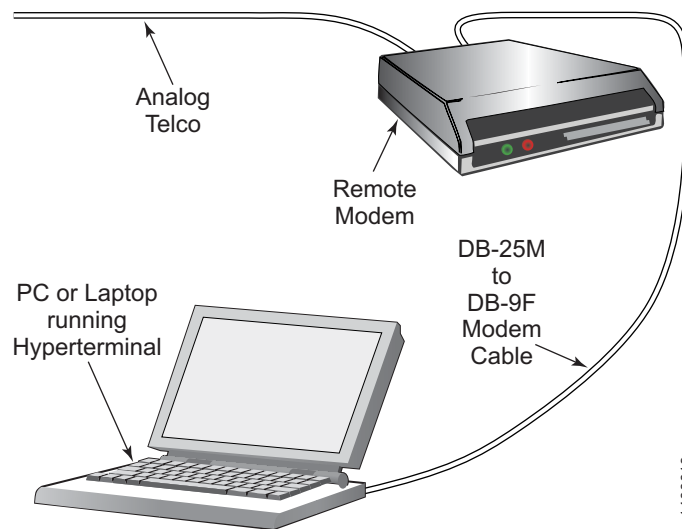

Figure 42. Remote modem setup

3. Launch the terminal emulator application and configure as described in Table 29 on page 118.

Table 29. Configuration parameters

Parameter	Value
Port speed (bits per second)	115200*
Data protocol	Standard EC
Compression	Enabled
Flow control	Hardware
Databits	Databits
Parity	None
Stop bits	1
Modulation	Standard
*Port usually defaults to highest speed supported by modem; might negotiate for slower speed.	

4. Follow the instructions from the modem manufacturer to set up and verify modem operation.

---

## Verifying the modem connection

This section provides information about how to verify that the modems are correctly connected.

**Note:** This procedure requires either a Telco system to dial in to the modems or a terminal emulation program on a laptop or workstation that has an attached modem. See “Setting up a remote modem system” on page 117 for instructions on setting up a remote modem with a terminal emulation program.

Complete the following steps to verify the modem connection:

1. Verify that both modem cables are firmly connected.
2. Power on the modems, if not already on.

**Note:** The modems must be powered on and operational before the director is powered on, to allow the director to detect the modems during boot.

3. Verify that both modems indicate they are ready by illuminating their Clear to Send (CS), Terminal Ready (TR), and Modem Ready (MR) indicators. If this does not occur, ensure that the modems are connected to a power source and are powered on. Check all modem cable connections.
4. Verify that POST is complete on the director (a minimum of 3 minutes).
5. Dial in to the telephone number assigned to the director, using a Telco system to dial-in to the modems or the setup described in “Setting up a remote modem system” on page 117.
6. Observe the modem lamps: the Ring indicator should flash briefly as the telephone rings. If the Ring indicator does not flash on both units, recheck the incoming telephone lines to the modems.
7. Verify that after one ring, the modem associated with the active CP blade (usually in slot 5), illuminates the Off Hook (OH) indicator on the modem and a login prompt is presented to the remote client.
8. Log in to the switch from the remote client as admin. The default password is password.

**Note:** If the Off Hook indicator illuminates on the standby CP blade modem, recheck the modem cable connection to the active CP blade.

9. Log out of the modem session.
10. Remove the Telco connector from the active CP blade modem, leaving the Telco line from the standby CP blade connected to the “Y” connector. See Figure 41 on page 116.

**Note:** The modem session is automatically disconnected if the modem cable is detached while a session is active.

11. Dial in to the telephone number assigned to the director, as described in “Setting up a remote modem system” on page 117.
12. Observe the modem lamps: the Ring indicator should flash only on the modem connected to the standby CP blade.
13. Verify that after seven rings, the Off Hook indicator on the standby CP blade modem is illuminated. A login prompt is presented to the remote client, and a message confirms that the standby CP blade is being logged in to. You can log in or disconnect the session, as desired.
14. Reconnect the Telco connector to the active CP blade modem. The director modems are ready for use.



---

## Appendix D. Port numbering template

Print or copy the template on the following page and use it to record the port numbering scheme for your SAN256B director. For each 16-port blade installed in the director, cross out the extra 16 ports on the graphical representation of the port blade before you fill in the port numbers.

You might find it useful to refer to “Port numbering” on page 7, which explains the port numbering methods, and Figure 3 on page 8, which displays the port numbering for a fully populated director (256 ports).

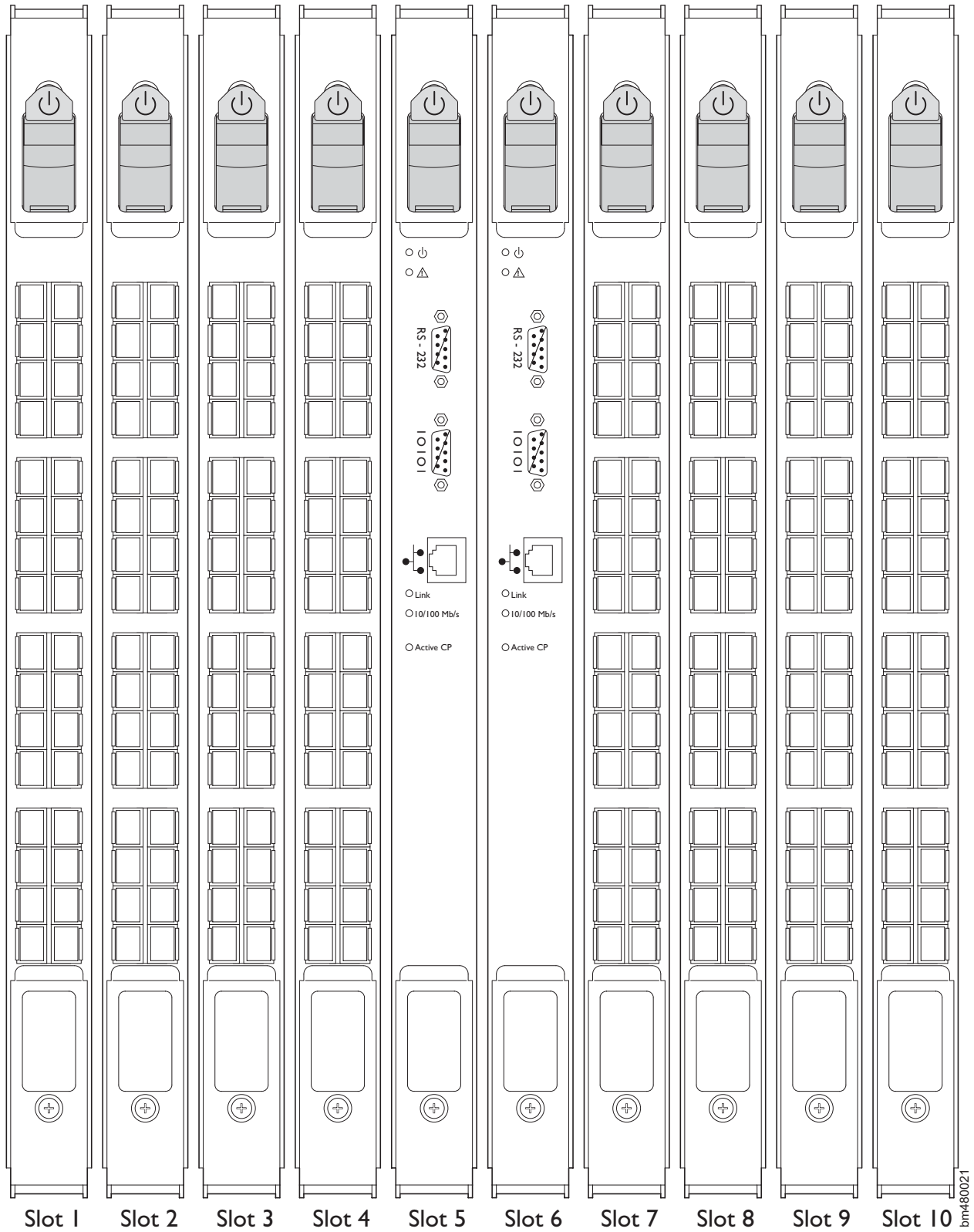

bm480021

Figure 43. SAN256B port numbering template

---

## Notices

This information was developed for products and services offered in the U. S. A.

IBM may not offer the products, services, or features discussed in this document in other countries. Consult your local IBM representative for information on the products and services currently available in your area. Any reference to an IBM product, program, or service is not intended to state or imply that only that IBM product, program, or service may be used. Any functionally equivalent product, program, or service that does not infringe on any IBM intellectual property right may be used instead. However, it is the user's responsibility to evaluate and verify the operation of any non-IBM product, program, or service.

IBM may have patents or pending patent applications covering subject matter described in this document. The furnishing of this document does not give you any license to these patents. You can send license inquiries, in writing to:

*IBM Director of Licensing  
IBM Corporation  
North Castle Drive  
Armonk, N.Y. 10504-1785  
U.S.A.*

For additional information, visit the web at:  
<http://www.ibm.com/ibm/licensing/contact/>

**The following paragraph does not apply to the United Kingdom or any other country where such provisions are inconsistent with local law:**

INTERNATIONAL BUSINESS MACHINES CORPORATION PROVIDES THIS PUBLICATION "AS IS" WITHOUT WARRANTY OF ANY KIND, EITHER EXPRESS OR IMPLIED, INCLUDING, BUT NOT LIMITED TO, THE IMPLIED WARRANTIES OF NON-INFRINGEMENT, MERCHANTABILITY OR FITNESS FOR A PARTICULAR PURPOSE. Some states do not allow disclaimer of express or implied warranties in certain transactions, therefore, this statement may not apply to you.

This information could include technical inaccuracies or typographical errors. Changes are periodically made to the information herein; these changes will be incorporated in new editions of the publication. IBM may make improvements and/or changes in the product(s) and/or the program(s) described in this publication at any time without notice.

Any references in this information to non-IBM web sites are provided for convenience only and do not in any manner serve as an endorsement of those web sites. The materials at those web sites are not part of the materials for this IBM product and use of those web sites is at your own risk.

IBM may use or distribute any of the information you supply in any way it believes appropriate without incurring any obligation to you.

Any performance data contained herein was determined in a controlled environment. Therefore, the results obtained in other operating environments may vary significantly. Some measurements may have been made on development-level systems and there is no guarantee that these measurements will be the same on generally available systems. Furthermore, some measurement may have been

estimated through extrapolation. Actual results may vary. Users of this document should verify the applicable data for their specific environment.

Information concerning non-IBM products was obtained from the suppliers of those products, their published announcements or other publicly available sources. IBM has not tested those products and cannot confirm the accuracy of performance, compatibility or any other claims related to non-IBM products. Questions on the capabilities of non-IBM products should be addressed to the suppliers of those products.

If you are viewing this information in softcopy, the photographs and color illustrations may not appear.



---

## Trademarks

The following terms are trademarks of the International Business Machines Corporation in the United States, other countries, or both:

IBM  
FICON  
TotalStorage

Brocade and SilkWorm are trademarks of Brocade Communications Systems, Inc., or its subsidiaries in the United States, other countries, or both.

Microsoft, Windows, and Windows NT<sup>®</sup> are trademarks of Microsoft Corporation in the United States, other countries, or both.

UNIX is a registered trademark of The Open Group in the United States and other countries.

Linux is a registered trademark of Linus Torvalds

Other company, product, or service names may be trademarks or service marks of others.

---

## Electronic emission notices

The following statements apply to this product. The statements for other products intended for use with this product will appear in their accompanying manuals.

### Federal Communications Commission (FCC) Class A Statement

**Note:** This equipment has been tested and found to comply with the limits for a Class A digital device, pursuant to Part 15 of the FCC Rules. These limits are designed to provide reasonable protection against harmful interference when the equipment is operated in a commercial environment. This equipment generates, uses, and can radiate radio frequency energy and, if not installed and used in accordance with the instruction manual, may cause harmful interference to radio communications. Operation of this equipment in a residential area is likely to cause harmful interference, in which case the user will be required to correct the interference at his own expense.

IBM is not responsible for any radio or television interference caused by unauthorized changes or modifications to this equipment. Unauthorized changes or modifications could void the user's authority to operate the equipment.

This device complies with Part 15 of the FCC Rules. Operation is subject to the following two conditions: (1) this device may not cause harmful interference, and (2) this device must accept any interference received, including interference that may cause undesired operation.

### Industry Canada Class A Emission Compliance Statement

This Class A digital apparatus complies with Canadian ICES-003.

### Avis de conformité à la réglementation d'Industrie Canada

Cet appareil numérique de la classe A est conforme à la norme NMB-003 du Canada.

## European Union (EU) Electromagnetic Compatibility Directive

This product is in conformity with the protection requirements of EU Council Directive 89/336/EEC on the approximation of the laws of the Member States relating to electromagnetic compatibility. IBM cannot accept responsibility for any failure to satisfy the protection requirements resulting from a non-recommended modification of the product, including the fitting of non-IBM option cards.

This product has been tested and found to comply with the limits for Class A Information Technology Equipment according to European Standard EN 55022. The limits for Class A equipment were derived for commercial and industrial environments to provide reasonable protection against interference with licensed communication equipment.

**Attention:** This is a Class A product. In a domestic environment this product may cause radio interference in which case the user may be required to take adequate measures.

## Japan VCCI Class A ITE Electronic Emission Statement

この装置は、情報処理装置等電波障害自主規制協議会（VCCI）の基準に基づくクラスA情報技術装置です。この装置を家庭環境で使用すると電波妨害を引き起こすことがあります。この場合には使用者が適切な対策を講ずるよう要求されることがあります。

vcci

## Korea Class A Electronic Emission Statement

이 기기는 업무용으로 전자파 적합등록을 받은 기기 이오니, 판매자 또는 사용자는 이점을 주의하시기 바라며, 만약 잘못 구입하셨을 때에는 구입한 곳에서 비업무용으로 교환하시기 바랍니다.

---

## Glossary

This glossary provides definitions for Fibre Channel and switch terminology used for IBM TotalStorage SAN switches and related products. It also provides additional definitions of technical terms and abbreviations. If you do not find the term you are looking for, see the *IBM Terminology* located at <http://www.ibm.com/ibm/terminology/>

This glossary includes terms and definitions from:

- *Information Technology Vocabulary* by Subcommittee 1, Joint Technical Committee 1, of the International Organization for Standardization and the International Electrotechnical Commission (ISO/IEC JTC1/SC1). Definitions are identified by the symbol (I) after the definition; definitions taken from draft international standards, committee drafts, and working papers by ISO/IEC JTC1/SC1 are identified by the symbol (T) after the definition, indicating that final agreement has not yet been reached among the participating National Bodies of SC1.

The following cross-reference conventions are used in this glossary:

**See** Refers you to (a) a term that is the expanded form of an abbreviation or acronym, or (b) a synonym or more preferred term.

**See also** Refers you to a related term.

### A

**access control list (ACL).** In computer security, a list associated with an object that identifies all the subjects that can access the object and their access rights. For example, an access control list is a list that is associated with a file that identifies the users who can access the file and that identified the user's access rights to that file.

**ACL.** See *access control list*.

**address identifier.** A 24-bit or 8-bit value used to identify the source or destination of a frame.

**alias.** An alternate name for an element or group of elements in the fabric. Aliases can be used to simplify the entry of port numbers and worldwide names (WWNs) when creating zones.

**alias address identifier.** An address identifier recognized by a port in addition to its standard identifier. An alias address identifier can be shared by multiple ports.

**alias AL\_PA.** An arbitrated loop physical address (AL\_PA) value recognized by a loop port (L\_port) in addition to the AL\_PA assigned to the port. See also *arbitrated loop physical address*.

**alias server.** A fabric software facility that supports multicast group management.

**AL\_PA.** See *arbitrated loop physical address*.

**American National Standards Institute (ANSI).** The governing body for Fibre Channel standards in the U.S.

**ANSI.** See *American National Standards Institute*.

**API.** See *application programming interface*.

**application programming interface (API).** An interface that allows an application program that is written in a high-level language to use specific data or functions of the operating system or another program.

**application-specific integrated circuit (ASIC).** A computer chip designed for a particular application.

**ARB.** See *arbitrative primitive signal*.

**arbitrative primitive signal (ARB).** A primitive signal that is transmitted as the fill word by a loop port (L\_port) to indicate that the L\_port is arbitrating to access to the loop. Applies only to the arbitrated loop topology.

**arbitrated loop.** A shared 100 MBps Fibre Channel transport structured as a loop and supporting up to 126 devices and one fabric attachment. A port must successfully arbitrate before a circuit can be established.

**arbitrated loop physical address (AL\_PA).** An 8-bit value used to uniquely identify an individual port within a loop. A loop can have one or multiple AL\_PAs.

**arbitration.** A method of gaining orderly access to a shared-loop topology.

**arbitration wait timeout value (AW\_TOV).** The minimum time an arbitrating loop port (L\_port) waits for a response before beginning loop initialization.

**area number.** A number that is assigned to each potential port location in the switch. Used to distinguish ports that have the same port number but are on different port cards.

**ASIC.** See *application-specific integrated circuit*.

**asynchronous transfer mode (ATM).** A method of transmission in which the sending and receiving of data is controlled by control characters such as a start bit and a stop bit, instead of by a timing sequence.

**ATM.** See *asynchronous transfer mode*.

**autonegotiation.** A universal mechanism to exchange network capabilities between two Ethernet nodes. The exchange takes place at power-up (or link reset) time. It automatically establishes a link that takes advantage of the highest common denominator of the mutual capabilities of the two Ethernet nodes. The universal mechanism negotiates capabilities that include link speed, PHY types, and full duplex or half duplex.

**autoranging.** A power supply that accommodates different input voltages and line frequencies.

**AW\_TOV.** See *arbitration wait timeout value*.

## B

**backup FCS switch.** The switch or switches assigned as backup in case the primary fabric configuration server (FCS) switch fails. See also *fabric configuration server switch* and *primary FCS switch*.

**bandwidth.** (1) The total transmission capacity of a cable, link, or system. Usually measured in bits per second (bps). (2) The range of transmission frequencies available to a network. See also *throughput*.

**basic input/output system (BIOS).** Code that controls basic hardware operations, such as interactions with diskette drives, hard disk drives, and the keyboard.

**BB\_credit.** See *buffer-to-buffer credit*.

**beacon.** When all the port light-emitting diodes (LEDs) on a switch are set to flash from one side of the switch to the other, to enable identification of an individual switch in a large fabric. A switch can be set to beacon by a CLI command or through Web Tools.

**beginning running disparity.** The disparity at the transmitter or receiver when the special character associated with an ordered set is encoded or decoded. See also *disparity*.

**BER.** See *bit error rate*.

**BIOS.** See *basic input/output system*.

**BISR.** Built-in self-repair.

**BIST.** Built-in self-test.

**bit error rate (BER).** The rate at which bits are expected to be received in error. Expressed as the ratio of error bits to total bits transmitted. See also *error*.

**blade.** A component that provides application-specific services and components. A blade is typically a hot swappable hardware device.

**block.** As applies to Fibre Channel, upper-level application data that is transferred in a single sequence.

**boot code.** Software that initialized the system environment during the early phase of the boot-up process. For example, boot code might determine the amount of available memory and how to access it.

**boot flash.** Flash memory that stores the boot code and boot parameters. The processor runs its first instructions from boot flash. Data is cached in random access memory (RAM).

**British thermal unit (Btu).** The amount of heat required to raise a pound of water by 1 degree Fahrenheit.

**broadcast.** The transmission of data from a single source to all devices in the fabric, regardless of zoning. See also *multicast* and *unicast*.

**Btu.** See *British thermal unit*.

**buffer-to-buffer credit.** The number of frames that can be transmitted to a directly-connected recipient or within an arbitrated loop. Determined by the number of receive buffers available. See also *buffer-to-buffer flow control*.

**buffer-to-buffer flow control.** Management of the frame transmission rate in either a point-to-point topology or in an arbitrated loop. See also *buffer-to-buffer credit*.

## C

**CAM.** Content addressable memory.

**cache.** A buffer that contains frequently accessed instructions and data; it is used to reduce access time.

**cascade.** Two or more interconnected Fibre Channel switches that can build large fabrics. Switches can be cascaded up to 239 switches, with a recommended maximum of seven inter-switch links (no path longer than eight switches). See also *fabric* and *inter-switch link*.

**central processing unit (CPU).** The part of a computer that includes the circuits that control the interpretation and running of instructions. A CPU is the circuitry and storage that executes instructions. Traditionally, the complete processing unit was often regarded as the CPU, whereas today the CPU is often a microchip. In either case, the centrality of a processor or processing unit depends on the configuration of the system or network in which it is used.

**Challenge Handshake Authentication Protocol (CHAP).** (1) An authentication protocol that protects against eavesdropping by encrypting the user name and password. (2) Allows remote servers and clients to securely exchange authentication credentials.

**chassis.** The metal frame in which the switch and switch components are mounted.

**CIM.** See *Common Information Model*

**circuit.** An established communication path between two ports. Consists of two virtual circuits capable of transmitting in opposite directions. See also *link*.

**class 1 service.** The class of frame-switching service for a dedicated connection between two communicating ports (also called "connection-oriented service"). Includes acknowledgement of frame delivery or nondelivery.

**class 2 service.** A connectionless class of frame-switching service that includes acknowledgement of frame delivery or nondelivery.

**class 3 service.** A connectionless class of frame-switching service that does not include acknowledgement of frame delivery or nondelivery. Can be used to provide a multicast connection between the frame originator and recipients, with acknowledgement of frame delivery or nondelivery.

**class 4 service.** A connection-oriented service that allows fractional parts of the bandwidth to be used in a virtual circuit.

**class 6 service.** A connection-oriented multicast service geared toward video broadcasts between a central server and clients.

**class F service.** The class of frame-switching service for a direct connection between two switches, allowing communication of control traffic between the E\_Ports. Includes acknowledgement of data delivery or nondelivery.

**class of service.** A specified set of delivery characteristics and attributes for frame delivery.

**CLI.** See *command line interface*.

**client.** A system or process that is dependent on another system or process (usually called the server) to provide it with access to data, services, programs, or resources.

**comma.** A unique pattern (either 1100000 or 0011111) used in 8b/10b encoding to specify character alignment within a data stream.

**command line interface (CLI).** Interface that depends entirely on the use of commands, such as through Telnet or simple network management protocol (SNMP), and does not involve a graphical user interface.

**Common Information Model (CIM).** An implementation-neutral, object-oriented schema for describing network management information. The Distributed Management Task Force (DMTF) develops and maintains CIM specifications.

**community (SNMP).** A relationship between a simple network management protocol (SNMP) agent and a set of SNMP managers that defines authentication, access control, and proxy characteristics.

**compact flash.** Flash (temporary) memory that is used in a manner similar to hard disk storage. It is connected to a bridging component that connects to the PCI bus of the processor. Not visible within the processor's memory space.

**control processor (CP).** The central processing unit that provides all control and management functions in a switch.

**control processor card (CP card).** The central processing unit of the director/switch, which contains two control processor (CP) card slots to provide redundancy. Provides Ethernet, serial, and modem ports with the corresponding light-emitting diodes (LEDs).

**CP.** See *control processor*.

**CP card.** See *control processor card*.

**CPU.** See *central processing unit*.

**credit.** When applied to a switch, the maximum number of receive buffers provided by a fabric port (F\_port) or fabric loop port (FL\_port) to its attached node port (N\_port) or node loop port (NL\_port), respectively, such that the N\_port or NL\_port can transmit frames without over-running the F\_port or FL\_port.

**CRU.** See *customer replaceable unit*

**CSA.** Canadian Standards Association.

**customer replaceable unit (CRU).** An assembly that is replaced in its entirety by a customer when any one of its components fails. In contrast, a field replaceable unit (FRU) can only be replaced by a qualified service representative.

**cut-through.** A switching technique that allows the route for a frame to be selected as soon as the destination address is received. See also *route*.

## D

**data rate.** The rate at which data is transmitted or received from a device. Interactive applications tend to require a high data rate, while batch applications can usually tolerate lower data rates.



**DB-9 connector.** A 9-pin version of the RS-232C port interface.

**dc.** Direct current.

**defined zone configuration.** The complete set of all zone objects that are defined in the fabric. The defined configuration can include multiple zone configurations. See also *enabled zone configuration* and *zone configuration*.

**DHCP.** Dynamic Host Configuration Protocol.

**disparity.** The proportion of ones and zeros in an encoded character. *Neutral disparity* means an equal number of each, *positive disparity* means a majority of ones, and *negative disparity* means a majority of zeros.

**DLS.** See *dynamic load sharing*.

**DMA.** See *direct memory access*.

**DNS.** Distributed name server.

**domain\_ID.** Unique identifier for the switch in a fabric. Usually automatically assigned by the switch, but can also be assigned manually. Can be any value between 1–239.

**DRAM.** See *dynamic random access memory*.

**DTE.** Data terminal equipment. Usually refers to a terminal.

**DWDM.** Dense wavelength division multiplexing. Allows more wavelengths to use the same fiber.

**dynamic random access memory (DRAM).** A storage in which the cells require repetitive application of control signals to retain stored data.

## E

**edge fabric.** A single fabric that uses two or more switches as a core to interconnect multiple edge switches. Synonymous with dual-core fabric. See also *resilient core*.

**edge switch.** A switch whose main task is to connect nodes into the fabric. See also *core switch*.

**E\_D\_TOV.** See *error detect timeout value*.

**EE\_credit.** See *end-to-end credit*.

**effective zone configuration.** The particular zone configuration that is currently in effect. Only one configuration can be in effect at once. The effective configuration is built each time a zone configuration is enabled.

**EIA.** Electronic Industries Alliance.

**EIA rack.** A storage rack that meets the standards set by the Electronics Industries Alliance (EIA).

**electromagnetic compatibility (EMC).** The design and test of products to meet legal and corporate specifications dealing with the emissions and susceptibility to frequencies in the radio spectrum. Electromagnetic compatibility is the ability of various electronic equipment to operate properly in the intended electromagnetic environment.

**electromagnetic interference (EMI).** Waves of electromagnetic radiation, including but not limited to radio frequencies, generated by the flow of electric current.

**electrostatic discharge (ESD).** The flow of current that results when objects having a static charge come into close enough proximity to discharge.

**ELP.** Extended link parameters.

**ELWL.** See *extra long wavelength*.

**EMC.** See *electromagnetic compatibility*.

**EMI.** See *electromagnetic interference*.

**enabled zone configuration.** The currently enabled configuration of zones. Only one configuration can be enabled at a time. See also *defined zone configuration* and *zone configuration*.

**end port.** A port on an edge switch that connects a device to the fabric.

**end-to-end credit (EE\_credit).** The number of receive buffers allocated by a recipient port to an originating port. Used by class 1 and class 2 services to manage the exchange of frames across the fabric between source and destination. See also *end-to-end flow control* and *buffer-to-buffer credit*.

**end-to-end flow control.** Governs flow of class 1 and class 2 frames between node ports (N\_ports). See also *end-to-end credit*.

**E\_port.** See *expansion port*.

**error.** As applies to fibre channel, a missing or corrupted frame, timeout, loss of synchronization, or loss of signal (link errors). See also *loop failure*.

**error detect timeout value (E\_D\_TOV).** The time that the switch waits for an expected response before declaring an error condition. Adjustable in 1 microsecond increments from 2—10 seconds.

**ESD.** See *electrostatic discharge*.

**exchange.** The highest level Fibre Channel mechanism used for communication between node

ports (N\_ports). Composed of one or more related sequences, and can work in either one or both directions.

**expansion port (E\_port).** A port is designated an expansion port (E\_port) when it is used as an inter-switch expansion port to connect to the E\_port of another switch, to build a larger switch fabric.

## F

**fabric.** A collection of Fibre Channel switches and devices, such as hosts and storage. Also referred to as a "switched fabric."

**fabric login (FLOGI).** The process by which a device gains access to the fabric.

**fabric loop port (FL\_port).** A fabric port that is loop capable. Used to connect node loop ports (NL\_ports) to the switch in a loop configuration.

**Fabric Manager.** An optionally licensed software feature. Fabric Manager is a GUI that allows for fabric-wide administration and management. Switches can be treated as groups, and actions such as firmware downloads can be performed simultaneously.

**fabric mode.** One of the modes for a loop port (L\_port). An L\_port is in fabric mode when it is connected to a port that is not loop capable and is using fabric protocol. See also *loop port* and *loop mode*.

**fabric name.** The unique identifier assigned to a fabric and communicated during login and port discovery.

**Fabric OS.** An operating system made up of two software components: the firmware that initializes and manages the switch hardware, and diagnostics.

**fabric port (F\_port).** A port that is able to transmit under fabric protocol and interface over links. Can be used to connect a node port (N\_port) to a switch. See also *fabric loop port* and *Fx\_port*.

**Fabric Watch.** An optionally licensed software feature. Fabric Watch can be accessed through either the command line or Advanced Web Tools, and it provides the ability to set thresholds for monitoring fabric conditions.

**failover.** The process of passing control from one redundant unit to another, in a nondisruptive manner.

**FAN.** Fabric address notification.

**FC.** See *fibre channel*.

**FCA.** See *Fibre Channel arbitrated loop*.

**FC-AL.** See *Fibre Channel arbitrated loop*.

**FC-AL-3.** The Fibre Channel Arbitrated Loop standard defined by ANSI. Defined on top of the FC-PH standards.

**FCC.** Federal Communications Commission.

**FC-FLA.** The Fibre Channel Fabric Loop Attach standard defined by ANSI.

**FCP.** See *Fibre Channel protocol*.

**FC-PDLA.** The Fibre Channel Private Loop Direct Attach standard defined by ANSI. Applies to the operation of peripheral devices on a private loop.

**FC-PH-1,2,3.** The Fibre Channel Physical and Signaling Interface standards defined by ANSI. (first, second, and third generations)

**FC-PI.** The Fibre Channel Physical Interface standard defined by ANSI.

**FCS switch.** See *fabric configuration server switch*.

**FC-SW-2.** The second generation of the Fibre Channel Switch Fabric standard defined by ANSI. Specifies tools and algorithms for the interconnection and initialization of Fibre Channel switches in order to create a multiswitch Fibre Channel fabric.

**Fibre Channel (FC).** The primary protocol used for building SANs to transmit data between servers, switches, and storage devices. Unlike IP and Ethernet, Fibre Channel was designed to support the needs of storage devices of all types. It is a high-speed, serial, bidirectional, topology-independent, multiprotocol, and highly scalable interconnection between computers, peripherals, and networks.

**Fibre Channel arbitrated loop (FC-AL).** A standard defined on top of the FC-PH standard. It defines the arbitration on a loop where several FC nodes share a common medium.

**Fibre Channel protocol (FCP).** The protocol for transmitting commands, data, and status using Fibre Channel FC-FS exchanges and information units. Fibre Channel is a high-speed serial architecture that allows either optical or electrical connections at data rates from 265 Mbps up to 4-Gbps.

**Fibre Channel service (FS).** A service that is defined by Fibre Channel standards and exists at a well-known address. For example, the Simple Name Server is a Fibre Channel service. See also *Fibre Channel service protocol*.

**Fibre Channel service protocol (FSP).** The common protocol for all fabric services, transparent to the fabric type or topology. See also *Fibre Channel service*.

**Fibre Channel shortest path first (FSPF).** A routing protocol used by Fibre Channel switches.

**Fibre Channel transport.** A protocol service that supports communication between Fibre Channel service providers. See also *Fibre Channel service protocol*.

**field replaceable unit (FRU).** An assembly that is replaced in its entirety by a service representative when any one of its components fails. In some cases, a field replaceable unit can contain other field replaceable units.

**File Transfer protocol (FTP).** In Transmission Control protocol/Internet protocol (TCP/IP), an application protocol used for transferring files to and from host computers.

**fill word.** An IDLE or ARB ordered set that is transmitted during breaks between data frames to keep the Fibre Channel link active.

**firmware.** The basic operating system provided with the hardware.

**FLA.** Fabric loop attach.

**flash partition.** Two redundant usable areas, called *partitions* into which firmware can be downloaded in the director/switch.

**FLOGI.** See *fabric login*.

**FL\_port.** See *fabric loop port*.

**F\_port.** See *fabric port*.

**frame.** The Fibre Channel structure used to transmit data between ports. Consists of a start-of-frame delimiter, header, any optional headers, the data payload, a cyclic redundancy check (CRC), and an end-of-frame delimiter. There are two types of frames: link control frames (transmission acknowledgements, and so on) and data frames.

**frame delimiter.** A part of an ordered set that marks frame boundaries and describes frame contents. See also *ordered set*.

**FRU.** See *field replaceable unit*.

**FS.** See *Fibre Channel service*.

**FSP.** See *Fibre Channel service protocol*.

**FSPF.** See *Fibre Channel shortest path first*.

**FTP.** See *File Transfer protocol*.

**full duplex.** A mode of communication that allows the same port to simultaneously transmit and receive frames. See also *half duplex*.

**Fx\_port.** A fabric port that can operate as either a fabric port (F\_port) or fabric loop port (FL\_port). See also *fabric port* and *fabric loop port*.

## G

**gateway.** Hardware that connects incompatible networks by providing the necessary translation for both hardware and software.

**GBIC.** See *gigabit interface converter*.

**Gbps.** Gigabits per second.

**GBps.** Gigabytes per second.

**generic port (G\_port).** A generic port that can operate as either an expansion port (E\_port) or a fabric port (F\_port). A port is defined as a G\_port when it is not yet connected or has not yet assumed a specific function in the fabric.

**gigabit interface converter (GBIC).** A removable serial transceiver module designed to provide gigabaud capability for fibre channel (FC) and other products that use the same physical layer.

**G\_port.** See *generic port*.

## H

**HA.** See *high availability*.

**half duplex.** A mode of communication that allows a port to either transmit or receive frames at any time, but not simultaneously (with the exception of link control frames, which can be transmitted at any time). See also *full duplex*.

**hard address.** The arbitrated loop physical address (AL\_PA) that a node loop port (NL\_port) attempts to acquire during loop initialization.

**hardware translative mode.** Method for achieving address translation. The two hardware translative modes that are available to a QuickLoop-enabled switch are standard translative mode and QuickLoop mode. See also *standard translative mode* and *QuickLoop mode*.

**HBA.** See *host bus adapter*.

**high availability.** An attribute of equipment that identifies it as being capable of operating well in excess of 99 percent of the time. High Availability is typically identified by the number of nines in that percentage. For example, a switch that is rated at five nines would be capable of operating 99.999 percent of the time without failure.

**host.** A computer that is connected to a network and provides an access point to that network. The host can be a client, a server, or both a client and server simultaneously.



**host bus adapter (HBA).** The interface card between a server or workstation bus and the Fibre Channel network.

**hot-pluggable.** A field replaceable unit (FRU) that can be removed or installed without turning the system off. Also called "hot swappable."

**hot swappable.** See *hot-pluggable*.

**HTTP.** See *Hypertext Transfer Protocol*.

**hub.** A Fibre Channel device that connects nodes into a logical loop by using a physical star topology. Hubs will automatically recognize an active node and insert the node into the loop. A node that fails or is powered off is automatically removed from the loop.

**Hypertext Transfer Protocol (HTTP).** In the Internet suite of protocols, the protocol that is used to transfer and display hypertext and XML documents on the Web.

## I

**ID.** Identification.

**idle.** Continuous transmission of an ordered set over a Fibre Channel link when no data is being transmitted, to keep the link active and maintain bit, byte, and word synchronization.

**in-band.** Transmission of management protocol over the Fibre Channel.

**initiator.** A server or workstation on a Fibre Channel network that initiates communications with storage devices. See also *target*.

**in-order delivery (IOD).** A parameter that, when set, guarantees that frames are either delivered in order or dropped.

**Internet protocol (IP).** A protocol that routes data through a network or interconnected networks. Internet Protocol (IP) acts as an intermediary between the higher protocol layers and the physical network.

**inter-switch link (ISL).** A Fibre Channel link that connects two switches (a link from the expansion port (E\_port) of one switch to the E\_port of another).

**IOD.** See *in-order delivery*.

**IP.** See *internet protocol*.

**ISL.** See *inter-switch link*.

**ISL Trunking.** A feature that enables distribution of traffic over the combined bandwidth of up to four inter-switch links (ISLs) (between adjacent switches), while preserving in-order delivery. A set of trunked ISLs

is called a *trunking group*; each port employed in a trunking group is called a *trunking port*. See also *master port*.

**isolated E\_port.** An expansion port (E\_port) that is online but not operational between switches due to overlapping domain ID or nonidentical parameters such as error delay timeout values (E\_D\_TOVs). See also *expansion port*.

## J

**JBOD.** Just a bunch of disks.

## K

**K28.5.** A special 10-bit character used to indicate the beginning of a transmission word that performs fibre channel control and signaling functions. The first seven bits of the character are the comma pattern. See also *comma*.

**kernel flash.** Flash memory that stores the bootable kernel code and is visible within the memory space of the processor. Data is stored as raw bits.

**key.** A string of data (usually a numeric value) shared between two entities and used to control a cryptographic algorithm. Usually selected from a large pool of possible keys to make unauthorized identification of the key difficult. See also *key pair*.

**key pair.** In public key cryptography, a pair of keys consisting of a public and private key of an entity. The public key can be publicized, but the private key must be kept secret.

## L

**LAN.** See *local area network*.

**latency.** The period of time required to transmit a frame, from the time it is sent until it arrives.

**LED.** See *light-emitting diode*.

**light-emitting diode (LED).** An electronic component that gives off visible or infrared light when electricity is passed through it. It is used to indicate the status of elements on a switch.

**link.** As applies to fibre channel, a physical connection between two ports, consisting of both transmit and receive fibers. See also *circuit*.

**link services.** A protocol for link-related services.

**LIP.** See *loop initialization primitive*.

**LM\_TOV.** See *loop master timeout value*.

**local area network (LAN).** A network that connects several devices into a limited area (such as a single building or campus) and that can be connected to a larger network.

**logical unit number (LUN).** An identifier used on a SCSI bus to distinguish among devices (logical units) with the same SCSI ID.

**long wavelength (LWL).** A type of fiber optic cabling that is based on 1300 nm lasers and supports link speeds of 1.0625 Gbps. Can also refer to the type of GBIC or SFP. See also *short wavelength*.

**loop.** A configuration of devices that are connected to the fabric by way of a fabric loop port (FL\_port) interface card.

**loop circuit.** A temporary bidirectional communication path established between loop ports (L\_ports).

**loop failure.** Loss of signal within a loop for any period of time, or loss of synchronization for longer than the timeout value.

**loop\_ID.** A hexadecimal value representing one of the 127 possible arbitrated loop physical address (AL\_PA) values in an arbitrated loop.

**loop initialization.** The logical procedure used by a loop port (L\_port) to discover its environment. Can be used to assign arbitrated loop physical address (AL\_PA) addresses, detect loop failure, or reset a node.

**loop initialization primitive (LIP).** The signal used to begin initialization in a loop. Indicates either loop failure or resetting of a node.

**looplet.** A set of devices connected in a loop to a port that is a member of another loop.

**loop master timeout value (LM\_TOV).** The minimum time that the loop master waits for a loop initialization sequence to return.

**loop mode.** One of the modes for a loop port (L\_port). An L\_port is in loop mode when it is in an arbitrated loop and is using loop protocol. An L\_port in loop mode can also be in participating mode or nonparticipating mode. See also *loop port*, *fabric mode*, *participating mode*, and *nonparticipating mode*.

**loop port (L\_port).** A node port (NL\_port) or fabric port (FL\_port) that has arbitrated loop capabilities. An L\_port can be either in fabric mode or loop mode. See also *fabric mode*, *loop mode*, *nonparticipating mode*, and *participating mode*.

**loop port state machine (LPSM).** The logical entity that performs arbitrated loop protocols and defines the behavior of loop ports (L\_ports) when they require access to an arbitrated loop.

**L\_port.** See *loop port*.

**LPSM.** See *loop port state machine*.

**LSAN.** Logical storage area network. An LSAN enables device and storage connectivity that spans two or more fabrics.

**LSR.** Link state record.

**LSU.** Link state update.

**LUN.** See *logical unit number*.

**LWL.** See *long wavelength*.

## M

**management information base (MIB).** A simple network management protocol (SNMP) structure to help with device management, providing configuration and device information.

**master port.** As relates to trunking, the port that determines the routing paths for all traffic flowing through the trunking group. One of the ports in the first inter-switch link (ISL) in the trunking group is designated as the master port for that group. See also *ISL Trunking*.

**MIB.** See *management information base*.

**multicast.** The transmission of data from a single source to multiple specified node ports (N\_ports), as opposed to all the ports on the network. See also *broadcast* and *unicast*.

**multimode.** A fiber optic cabling specification that allows up to 500 m (1640.5 ft) between devices.

## N

**name server.** Frequently used to indicate Simple Name Server. See also *simple name server*.

**NEMA.** National Electrical Manufacturers Association.

**network time protocol (NTP).** An Internet standard protocol that provides synchronization of computer clock times in a network with times provided by radio or atomic clocks on the Internet.

**NL\_port.** See *node loop port*.

**node.** A Fibre Channel device that contains a node port (N\_port) or node loop port (NL\_port).

**node loop port (NL\_port).** A node port that has arbitrated-loop capabilities. Used to connect an equipment port to the fabric in a loop configuration through an FL\_Port.

**node name.** The unique identifier for a node, communicated during login and port discovery.

**node port (N\_port).** A port on a node that can connect to a Fibre Channel port or to another N\_Port in a point-to-point connection.

**nonparticipating mode.** A mode in which a loop port (L\_port) in a loop is inactive and cannot arbitrate or send frames, but can retransmit any received transmissions. This mode is entered if there are more than 127 devices in a loop and an arbitrated loop physical address (AL\_PA) cannot be acquired. See also *participating mode*.

**nonvolatile random access memory (NVRAM).** Random access memory (storage) that retains its contents after the electrical power to the machine is shut off. A specific part of NVRAM is set aside for use by the system ROS for the boot device list.

**N\_port.** See *node port*.

**NTP.** See *network time protocol*

**NVRAM.** See *nonvolatile random access memory*.

**Nx\_port.** A node port that can operate as either a node port (N\_port) or node loop port (NL\_port). See also *node port* and *node loop port*.

## O

**operating system (OS).** A collection of system programs that control the overall operation of a computer system.

**ordered set.** A transmission word that uses 8b/10b mapping and begins with the K28.5 character. Ordered sets occur outside of frames, and include frame delimiters, primitive signals, and primitive sequences. Ordered sets are used to differentiate Fibre Channel control information from data frames and to manage the transport of frames. See also *frame delimiter*, *primitive signal*, and *primitive sequence*.

**OS.** See *operating system*.

**out-of-band.** Transmission of management protocol outside of the Fibre Channel network, usually over Ethernet.

## P

**packet.** A set of information transmitted across a network. See also *frame*.

**parallel.** The simultaneous transmission of data bits over multiple lines.

**participating mode.** A mode in which a loop port (L\_port) in a loop has a valid arbitrated loop physical address (AL\_PA) and can arbitrate, send frames, and retransmit received transmissions. See also *nonparticipating mode*.

**path selection.** The selection of a transmission path through the fabric. Switches use the Fibre Channel shortest path first (FSPF) protocol.

**PDU.** Power distribution unit.

**Performance Monitoring.** A software feature that provides error and performance information to the administrator and user for use in storage management.

**phantom address.** An arbitrated loop physical address (AL\_PA) value that is assigned to a device that is not physically in the loop. Also known as phantom AL\_PA.

**phantom device.** A device that is not physically in an arbitrated loop, but is logically included through the use of a phantom address.

**PLDA.** See *private loop direct attach*.

**PLOGI.** See *port login*.

**P/N.** Part number.

**point-to-point.** A Fibre Channel topology that employs direct links between each pair of communicating entities. See also *topology*.

**port cage.** The metal casing extending out of the optical port on the switch, and in which the gigabit interface converter (GBIC) or small form-factor pluggable (SFP) can be inserted.

**port card.** A hardware component that provides a platform for field-replaceable, hot swappable ports.

**port login (PLOGI).** The port-to-port login process by which initiators establish sessions with targets. See also *fabric login*.

**port module.** A collection of ports in a switch.

**port\_name.** The unique identifier assigned to a Fibre Channel port. Communicated during login and port discovery.

**POST.** See *power-on self-test*.

**PPP.** Point-to-Point Protocol.

**power-on self-test (POST).** A series of diagnostics that are automatically run by a device when the power is turned on.

**primary FCS switch.** Primary fabric configuration server switch. The switch that actively manages the configuration and security parameters for all switches in the fabric. See also *backup FCS switch* and *FCS switch*.

**primitive sequence.** A part of an ordered set that indicates or initiates port states. See also *ordered set*.

**primitive signal.** A part of an ordered set that indicates events. See also *ordered set*.

**principal switch.** The switch that assumes the responsibility to assign domain IDs. The role of principal switch is negotiated after a “build fabric” event.

**private device.** A device that supports arbitrated loop protocol and can interpret 8-bit addresses, but cannot log into the fabric.

**private loop.** An arbitrated loop that does not include a participating fabric loop port (FL\_port).

**private key.** The secret half of a key pair.

**private loop direct attach (PLDA).** A subset of fibre channel standards for the operation of peripheral devices.

**private NL\_port.** A node loop port (NL\_port) that communicates only with other private NL\_ports in the same loop and does not log into the fabric.

**protocol.** A defined method and a set of standards for communication.

**public device.** A device that supports arbitrated loop protocol, can interpret 8-bit addresses, and can log into the fabric.

**public loop.** An arbitrated loop that includes a participating fabric loop port (FL\_port), and can contain both public and private node loop ports (NL\_ports).

**public NL\_port.** A node loop port (NL\_port) that logs into the fabric, can function within either a public or private loop, and can communicate with either private or public NL\_ports.

## Q

**quad.** A group of four adjacent ports that share a common pool of frame buffers.

**QuickLoop.** (1) A software feature that makes it possible to allow private devices within loops to communicate with public and private devices across the fabric through the creation of a larger loop. (2) The arbitrated loop created using this software. A QuickLoop can contain a number of devices or looplets; all devices in the same QuickLoop share a single arbitrated loop physical address (AL\_PA) space.

**QuickLoop mode.** A hardware translative mode that allows private devices to communicate with other private devices across the fabric. See also *hardware translative mode* and *standard translative mode*.

## R

**RAID.** See *redundant array of independent disks*.

**RAM.** See *random access memory*.

**random access memory (RAM).** A temporary storage location in which the central processing unit (CPU) stores and executes its processes.

**R\_A\_TOV.** See *resource allocation timeout value*.

**read only memory (ROM).** Memory in which stored data cannot be changed by the user except under special conditions.

**receiver ready (R\_RDY).** A primitive signal indicating that the port is ready to receive a frame.

**redundant array of independent disks (RAID).** A collection of disk drives that appear as a single volume to the server and are fault tolerant through mirroring or parity checking.

**registered state change notification (RSCN).** A switch function that allows notification of fabric changes to be sent from the switch to specified nodes.

**remote fabric.** A fabric that spans across wide area networks (WANs) by using protocol translation (a process also known as tunneling) such as fibre channel over asynchronous transfer mode (ATM) or fibre channel over Internet protocol (IP).

**remote switch.** An optional feature for long distance fabrics, requiring a Fibre Channel to ATM or SONET gateway.

**request rate.** The rate at which requests arrive at a servicing entity. See also *service rate*.

**resilience.** A fabric’s ability to adapt to or tolerate a failure of a component within the fabric.

**resilient core.** A single fabric that uses two or more switches as a core to interconnect multiple edge switches. Synonymous with dual-core fabric.

**resource allocation timeout value (R\_A\_TOV).** Used to time out operations that depend on the maximum possible time that a frame can be delayed in a fabric and still be delivered. This value is adjustable in one microsecond increments from 10—120 seconds.

**resource recover timeout value (RR\_TOV).** The minimum time a target device in a loop waits after a loop initialization primitive (LIP) before logging out a small computer systems interface (SCSI) initiator. See also *error detect timeout value* and *resource allocation timeout value*.

**RLS probing.** Read link status of the arbitrated loop physical addresses (AL\_PAs).

**ROM.** See *read only memory*.

**route.** As applies to a fabric, the communication path between two switches. Can also apply to the specific path taken by an individual frame, from source to destination. See also *Fibre Channel shortest path first*.

**routing.** The assignment of frames to specific switch ports, according to frame destination.

**R\_RDY.** See *receiver ready*.

**RR\_TOV.** See *resource recovery timeout value*.

**RS-232 port.** An older standard for a port that has been replaced by EIA/TIA-232-E. Used to connect data terminal equipment (DTE) and data communications equipment (DCE) devices for communication between components, terminals, and modems. See also *DB-9 connector*, *DCE port*, and *DTE port*.

**RSCN.** See *registered state change notification*.

**rw.** Read-write.

## S

**SAN.** See *storage area network*.

**SC.** Standard connector.

**SCSI.** See *small computer systems interface*.

**SCSI Enclosure Services (SES).** A subset of the small computer systems interface (SCSI) protocol used to monitor temperature, power, and fan status for enclosure devices.

**SDRAM.** See *synchronous dynamic random access memory*.

**Secure Fabric OS.** An optionally-licensed software product that runs on top of the Fabric OS and provides customizable security restrictions through local and remote management channels on a switch.

**secure sockets layer (SSL).** A security protocol that provides communication privacy. SSL enables client/server applications to communicate in a way that is designed to prevent eavesdropping, tampering, and message forgery.

**sequence.** A group of related frames transmitted in the same direction between two node ports (N\_ports).

**service rate.** The rate at which an entity can service requests. See also *request rate*.

**SES.** See *SCSI Enclosure Services*.

**SFP.** See *small form-factor pluggable*.

**short wavelength (SWL).** A type of fiber optic cabling that is based on 850 nm lasers and supports 1.0625

Gbps link speeds. Can also refer to the type of gigabit interface converter (GBIC) or small form-factor pluggable (SFP). See also *long wavelength*.

**SID.** The 3-byte source ID of the originator device, in the 0xDomainAreaALPA format.

**SID-DID.** Source identifier-destination identifier.

**SIMMS.** Single in-line modules.

**simple name server (SNS).** A switch service that stores names, addresses, and attributes for up to 15 minutes, and provides them as required to other devices in the fabric. SNS is defined by Fibre Channel standards and exists at a well-known address. Can also be referred to as directory service. See also *Fibre Channel service*.

**simple network management protocol (SNMP).** In the Internet suite of protocols, a network management protocol that is used to monitor routers and attached networks. SNMP is an application layer protocol. Information on devices managed is defined and stored in the application's Management Information Base (MIB).

**single mode.** The fiber optic cabling standard that corresponds to distances of up to 10 km (6.214 mi) between devices.

**small computer systems interface (SCSI).** A parallel bus architecture and a protocol for transmitting large data blocks up to a distance of 15–25 m (49–82 ft).

**small form-factor pluggable (SFP).** An optical transceiver used to convert optical and electrical signals between optical fiber cables and switches.

**SNMP.** See *simple network management protocol*.

**SNMPv1.** The original standard for SNMP, now labeled v1.

**SNS.** See *simple name server*.

**SOF.** Start-of-frame.

**SSL.** See *secure sockets layer*.

**standard translatable mode.** A hardware translatable mode that allows public devices to communicate with private devices across the fabric. See also *hardware translatable mode* and *QuickLoop mode*.

**storage.** A device used to store data, such as a disk or tape.

**storage area network (SAN).** A network of systems and storage devices that communicate using Fibre Channel protocols. See also *fabric*.

**subordinate switch.** All switches in the fabric other than the principal switch. See also *principal switch*.



**switch.** Hardware that routes frames according to Fibre Channel protocol and is controlled by software.

**switch name.** The arbitrary name assigned to a switch.

**switch port.** A port on a switch. Switch ports can be expansion ports (E\_ports), fabric ports (F\_ports), or fabric loop ports (FL\_ports).

**SWL.** See *short wavelength*.

**synchronous dynamic random access memory (SDRAM).** The main memory for the switch. Used for volatile storage during switch operation.

## T

**target.** A storage device on a Fibre Channel network. See also *initiator*.

**TCP.** See *transmission control protocol*.

**tenancy.** The time from when a port wins arbitration in a loop until the same port returns to the monitoring state. Also referred to as loop tenancy.

**throughput.** The rate of data flow achieved within a cable, link, or system. Usually measured in bits per second (bps). See also *bandwidth*.

**topology.** As applies to fibre channel, the configuration of the Fibre Channel network and the resulting communication paths allowed.

**transceiver.** A device that converts one form of signaling to another for transmission and reception; in fiber optic applications, optical and electrical signals are converted.

**translative mode.** A mode in which private devices can communicate with public devices across the fabric.

**transmission character.** A 10-bit character encoded according to the rules of the 8b/10b algorithm.

**Transmission control protocol (TCP).** A communications protocol used in the Internet and in any network that follows the Internet Engineering Task Force (IETF) standards for Internet protocol.

**transmission word.** A group of four transmission characters.

**trap (SNMP).** The message sent by a simple network management protocol (SNMP) agent to inform the SNMP management station of a critical error. See also *simple network management protocol*.

**tunneling.** A technique for enabling two networks to treat a transport network as though it were a single communication link or local area network (LAN).

**Tx.** Transmitted.

## U

**U.** Unit of measure for rack-mounted equipment.

**UDP.** See *user datagram protocol*.

**ULP.** See *upper-level protocol*.

**ULP\_TOV.** See *upper-level timeout value*.

**unicast.** The transmission of data from a single source to a single destination. See also *broadcast* and *multicast*.

**universal port (U\_port).** A switch port that can operate as a generic port (G\_port), expansion port (E\_port), fabric port (F\_port), or fabric loop port (FL\_port). A port is defined as a U\_port when it is not connected or has not yet assumed a specific function in the fabric.

**U\_port.** See *universal port*.

**upper-level protocol (ULP).** The protocol that runs on top of Fibre Channel. Typical upper-level protocols are small computer system interface (SCSI), Internet protocol (IP), HIPPI, and IPI.

**upper-level timeout value (ULP\_TOV).** The minimum time that a small computer system interface (SCSI) upper-level protocol (ULP) process waits for SCSI status before initiating ULP recovery.

**user datagram protocol (UDP).** A protocol that runs on top of Internet protocol (IP) and provides port multiplexing for upper-level protocols.

## V

**VC.** See *virtual circuit*.

**VCCI.** Voluntary Control Council for Interference

**virtual circuit (VC).** A one-way path between node ports (N\_ports) that allows fractional bandwidth.

## W

**WAN.** See *wide area network*.

**WDM.** Wave division multiplexing. Allows multiple wavelengths to be combined or filtered on a single cable.

**well-known address.** As it pertains to fibre channel, a logical address defined by the Fibre Channel standards as assigned to a specific function, and stored on the switch.

**wide area network (WAN).** A network that provides communication services to a geographic area larger than that served by a local area network or a metropolitan network, and that can use or provide public communications facilities.

**workstation.** A computer used to access and manage the fabric. Can also be referred to as a management station or host.

**worldwide name (WWN).** Uniquely identifies a switch on local and global networks.

**World Wide Web (WWW).** A network of servers that contain programs and files. Many of the files contain hypertext links to other documents available through the network.

**WWN.** See *worldwide name*.

**WWW.** See *World Wide Web*.

## Z

**zone.** A set of devices and hosts attached to the same fabric and configured as being in the same zone. Devices and hosts within the same zone have access permission to others in the zone, but are not visible to any outside the zone. See also *zoning*.

**zone alias.** An alias for a set of port numbers or worldwide names (WWNs). Zone aliases can be used to simplify the entry of port numbers and WWNs. For example, "host" could be used as an alias for a WWN of 110:00:00:60:69:00:00:8a.

**zone configuration.** A set of zones designated as belonging to the same zone configuration. When a zone configuration is in effect, all valid zones in that configuration are also in effect.

**zone member.** A port, node, worldwide name (WWN), or alias, which is part of a zone.

**zone scheme.** The level of zoning granularity selected. For example, zoning can be done by switch or port, worldwide name (WWN), arbitrated loop physical address (AL\_PA), or a mixture. See also *zone configuration*.

**zone set.** See *zone configuration*.

**Zoning.** A feature that runs on Fabric operating system (OS) and allows partitioning of the fabric into logical groupings of devices. Devices in a zone can only access and be accessed by devices in the same zone. See also *zone*.





---

# Index

## Numerics

- 24-inch load plate
  - part number 10
  - using 18

## A

- about this document xxiii
  - how to send your comments xxv
- ac power
  - removing xx
- address, IBM xxv
- Advanced Security 6
- Advanced Zoning 6
- attention notice
  - definition xvii
  - example xvii
- attention notices xvii

## B

- backing up the configuration 36
- base configuration 2
- battery
  - disposal xxi
  - return program xxi
  - specifications 104
- battery disposal xxi
- battery return xxi
- bend radius
  - minimum 56
- bezel
  - LEDs 46
- blade status
  - CP 40
  - port 37
- blade status, CP 40
- blades
  - FC4-16 57
  - FC4-32 57
- blower assembly
  - installing 76, 78
  - removing 76
- blower assembly LEDs 44
- blower assembly status 44
- brackets, installing 14
- bridge tool 10
  - ordering 10
  - using 18
- Brocade
  - documents xxiii
  - IBM product and model number matrix xxiv
- Brocade documents xxiii

## C

- C36
  - cabinet 9
- cabinet
  - C36 9
  - installing a SAN256B 13
- cable guides 53, 56
- cable management 51
- cable management tray 50, 52
  - installing 54, 56
  - removing 54, 55
- cable routing tables 97
- cable warning
  - lead content xxii
- cables, managing 50
- cables, routing 50
- caution notices xiv
  - definition xiv
  - examples xiv
- chassis
  - configuring serial number 93
  - critical information checklist 89
  - installing components 92
  - removing 91
  - replacing 91
- chassis door 49
  - installing 49
  - removing 12, 49
- chassis replacement, preparation 86
- chassis replacement, verifying need 85
- chassis serial number, configuring 93
- chassis, installing components 92
- chassis, replacing 85
- checklist
  - chassis critical information 89
- comments
  - how to send xxv
- component
  - status 37
- components
  - installing 49
  - removing 49
- configuration
  - backing up 36
  - parameters 30
- configuration parameters, initial 31
- configuring
  - director 27
  - IP addresses 32
- configuring chassis serial number 93
- confirming failed CP blade 64
- connecting to the fabric 34
- connection
  - serial 30
- connection, Ethernet 33
- cords, power 106
- CP blade 42

- CP blade (*continued*)
  - failed 64
  - installing 63, 68
  - removing 63, 66
  - specifications 104
  - status 64, 69
  - verifying 69
- CP blade LED patterns 42
- CP blade status 40
- CP blade, failed 64
- CP blade, installing 63, 68
- CP blade, removing 63, 66
- critical director information
  - recording 86
- critical information checklist, chassis 89
- critical SAN information
  - recording 86
- critical switch information, recording 65

## D

- danger notices xi
  - definitions xi
  - examples xi
- data, key 36
- diagnostics 109
- director
  - configuring 27
  - IP addresses 32
  - physical dimensions 100
  - providing initial power 28
  - starting 27
  - switch name 34
  - unpacking 11
  - weight 100
- director of licensing
  - address 123
- disconnecting
  - director from network and fabric 90
- documents
  - Brocade xxiii
  - product xxiii
- documents, Brocade xxiii
- documents, product xxiii
- Domain ID 34
- door
  - chassis
    - removing 12
- door, chassis 49

## E

- edition notice ii
- electronic emission notices 125
- enabling software licenses 35
- environmental
  - notices and statements xx
- environmental notices xi, xx
- environmental requirements 102
- ESD 59, 64
- ESD grounding strap 66, 90

- ESD strap 58
- Ethernet connection 33
  - establishing 33
- Extended Fabrics 6
- external machine checks xx
- extraction tool, SFP 57

## F

- fabric
  - connecting to 34
- fabric configuration 96
- fabric configuration, verifying 96
- Fabric Watch 6, 37
- fabric, connecting to 34
- fabric, reconnecting 95
- facility requirements 101
- failed CP blade, confirming 64
- FC4-16 port blades 57
- FC4-32 port blades 57
- features
  - high availability 4
- features and components 1
- features, optional 6
- features, software 6
- fiber-optic cable
  - minimum bend radius 56
  - slack 51
- FICON with CUP 6
- filler panel 57
- filler panel, installing 63
- filler panel, removing 60
- FRU
  - weights 100

## G

- getting help xxiv
- grounding strap, ESD 66, 90

## H

- hardware, verifying 93
- help xxiv
- high availability 4
  - features 4
- how to send your comments xxv

## I

- IBM
  - address xxv
  - notices 123
  - trademarks 125
- IBM product and model number matrix xxiv
- ID, Domain 34
- initial configuration parameters 31
- inspections, safety xx
- installation
  - planning 9

- installation (*continued*)
  - preparation 9
- installing
  - blower assembly 76, 78
  - brackets 14
  - cable management tray 56
  - chassis door 49, 50
  - components 49, 92
  - CP blade 63, 68
  - filler panel 57, 63
  - port blade 57, 61
  - power supply 71, 74
  - power supply filler panel 74
  - SAN256B 13, 18
    - time required 13
    - tools required 13
  - SAN256B director 9
  - SFPs 57
  - WWN bezel and card 79
  - WWN card 82
- installing components 49
- intellectual property 123
- internal machine checks xx
- introduction 1
- IP addresses 36
  - director 32
- IP addresses, director 32
- ISL Trunking 6

## K

- key data 36
  - IP addresses 36
  - license keys 36
  - passwords 36

## L

- labels, safety xvi
- lead content
  - cable warning xxii
- LED patterns
  - CP blade 42
  - power supply 44
- LED patterns, CP blade 42
- LED patterns, power supply 44
- LEDs 42, 43
  - blower assembly 44
  - patterns
    - blower assembly 45
    - CP blade 42
    - WWN card 46
- LEDs patterns
  - port blade 39
- LEDs patterns, port blade 39
- license keys 36
- license, for patents 123
- licenses, software 35
- licensing
  - Web address 123
- lift tool 10, 13

- lift tool (*continued*)
  - ordering procedure 10
  - part number 10
  - United States ordering procedure 10
  - using 18, 23
  - world trade ordering procedure 10

## M

- machine checks
  - external xx
  - internal xx
- managing cables 50
- modem 27
- modem serial port
  - specifications 105
- modems, reconnecting 93
- monitoring
  - component status 37
  - system components 37

## N

- network manageability 7
- Network Management System 7
- network, reconnecting 95
- notice, edition ii
- notices
  - attention xvii
  - battery xxi
  - caution xiv
  - danger xi
  - environmental xi, xx
  - IBM 123
  - safety xi
  - safety and environmental xi
  - types xi
- notices ,danger xi
- notices and labels
  - safety xi
- notices, attention xvii
- notices, caution xiv
- notices, environmental xx

## O

- optional features 6
- ordering the lift tool and the 24-inch load plate 10
- overview 1

## P

- parameters
  - configuration 30
- parameters, initial configuration 31
- part number
  - 24-inch load plate 10
  - lift tool 10
- parts
  - power cords 106

- password 31
  - changing 31
- passwords 36
- patents 123
- patterns, port blade LEDs 39
- Performance Monitoring 6, 37
- PID mode, verifying 34
- port blade
  - installing 57, 61
  - LEDs patterns 39
  - removing 57, 59
  - status 37
- port blade status 37
- port blades
  - FC4-16 57
  - FC4-32 57
- port blades, FC4-16 57
- port blades, FC4-32 57
- port numbering 7
  - fully populated (256 ports) 7
- power
  - cords
    - list 106
  - director 28
- power specifications 101
- power supply 43
  - filler panel 71, 74
  - installing 71, 74
  - LED patterns 44
  - LEDs 43
  - removing 71, 72
  - status 43
- power supply LED patterns 44
- power supply status 43
- preparing for chassis replacement 86
- product
  - base configuration 2
  - components 2
  - features 2
  - features and components 1
  - hardware components 2
  - introduction 1
  - overview 1
  - reliability 5
  - serviceability 5
  - software features 6
  - specifications 99
- product disposal xxi
- product documents xxiii
- product recycling xxi
- product specifications 99
- providing initial power to the director 28

## R

- rack
  - safety xviii
- rack installation
  - safety xviii
- rack relocation
  - safety xix

- rack safety xviii
- reader comment form xxv
- reconnecting modems 93
- reconnecting to the fabric 95
- reconnecting to the network 95
- recording
  - critical director information 86
  - critical SAN information 86
- recording critical switch information 65
- recycling and disposal xxi
- reliability 5
- Remote Switch 6
- removing
  - ac power xx
  - blower assembly 76
  - cable management tray 55
  - chassis 91
  - chassis door 12, 49
  - components 49, 90
  - CP blade 63, 66
  - filler panel 57, 60
  - port blade 57
  - power supply 71, 72
  - power supply filler panel 74
  - SAN256B 23
  - SAN256B director 9
  - SFPs 57
  - WWN bezel and card 79, 81
- removing components 49
- replacing
  - chassis 85, 91
  - WWN card 79
- requirements
  - environmental 102
  - facility 101
- return program, battery xxi
- routing cables 50

## S

- safety xi
  - inspections xx
  - labels xi, xvi
    - examples xvi
  - notices xi
  - rack xviii
  - rack installation xviii
  - rack relocation xix
- safety inspection
  - external machine checks xx
  - internal machine checks xx
- safety inspections xx
- safety labels xvi
- safety notices xi
- safety, rack xviii
- safety, rack installation xviii
- safety, rack relocation xix
- SAN Switch Cabinet C36 9
- SAN256B
  - library xxiii
  - removing 23

- SAN256B director
  - installing 9
  - removing 9
- security 6
- serial connection 30
- serial connection, establishing 30
- serial number, chassis 93
- serviceability 5
- setting
  - Domain ID 34
- SFP 35
  - extraction tool 57
- SFP extraction tool 57
- SFP transceivers 35
- SFPs
  - installing 57
  - removing 57
- slack
  - fiber-optic cable 51
- slack, cable 51
- SNMP 7, 37
- software features 6
  - optional
    - Advanced Security 6
    - Extended Fabrics 6
    - FICON with CUP 6
    - Remote Switch 6
- software features, optional 6
- software licenses
  - enabling 35
- specifications
  - battery 104
  - CP blade 104
  - modem serial port 105
  - power 101
  - terminal serial port 104
- specifications, product 99
- standard features
  - software
    - Advanced Zoning 6
    - Fabric Watch 6
    - ISL Trunking 6
    - Performance Monitoring 6
    - Web Tools 6
- standard software features 6
- starting
  - director 27
- status
  - blower assembly 44
  - component 37
  - CP blade 40
  - port blade 37
  - power supply 43
  - WWN card 46
- status, blower assembly 44
- status, CP blade 40
- status, power supply 43
- status, WWN card 46
- strap, ESD 58
- support xxiv
- switch name 34

- system architecture 99
- system components
  - monitoring 37
- system operation, verifying 94

## T

- tables, cable routing 97
- Telnet 6
- terminal serial port
  - specifications 104
- time required
  - installing a SAN256B 13
- tools required
  - installing a SAN256B 13
- trademarks 125
- transceivers 35
- transceivers, SFP 35

## U

- unpacking the director 11

## V

- verifying
  - chassis replacement need 85
  - fabric configuration 96
  - system operation 94
  - WWN card 80
- verifying hardware 93
- verifying PID mode 34
- verifying, CP blade 69
- VLAN 33

## W

- warning
  - cable xxii
- warning, cable xxii
- Web sites xxiv
- Web Tools 6, 37
- WEEE directive xxi
- weights, FRUs 100
- who should read this document xxiii
- WWN bezel 79
- WWN card 79
  - installing 82
  - LEDs 46
  - removing 81
- WWN card , verifying 80
- WWN card status 46
- WWN card, replacing 79



---

# Readers' Comments — We'd Like to Hear from You

IBM TotalStorage SAN256B Director  
Installation, Service, and User's Guide  
Service information: 2109/M48

Publication No. GC26-7761-00

Overall, how satisfied are you with the information in this book?

	Very Satisfied	Satisfied	Neutral	Dissatisfied	Very Dissatisfied
Overall satisfaction	<input type="checkbox"/>	<input type="checkbox"/>	<input type="checkbox"/>	<input type="checkbox"/>	<input type="checkbox"/>

How satisfied are you that the information in this book is:

	Very Satisfied	Satisfied	Neutral	Dissatisfied	Very Dissatisfied
Accurate	<input type="checkbox"/>	<input type="checkbox"/>	<input type="checkbox"/>	<input type="checkbox"/>	<input type="checkbox"/>
Complete	<input type="checkbox"/>	<input type="checkbox"/>	<input type="checkbox"/>	<input type="checkbox"/>	<input type="checkbox"/>
Easy to find	<input type="checkbox"/>	<input type="checkbox"/>	<input type="checkbox"/>	<input type="checkbox"/>	<input type="checkbox"/>
Easy to understand	<input type="checkbox"/>	<input type="checkbox"/>	<input type="checkbox"/>	<input type="checkbox"/>	<input type="checkbox"/>
Well organized	<input type="checkbox"/>	<input type="checkbox"/>	<input type="checkbox"/>	<input type="checkbox"/>	<input type="checkbox"/>
Applicable to your tasks	<input type="checkbox"/>	<input type="checkbox"/>	<input type="checkbox"/>	<input type="checkbox"/>	<input type="checkbox"/>

Please tell us how we can improve this book:

Thank you for your responses. May we contact you?  Yes  No

When you send comments to IBM, you grant IBM a nonexclusive right to use or distribute your comments in any way it believes appropriate without incurring any obligation to you.

---

Name

---

Address

---

Company or Organization

---

Phone No.



Fold and Tape

Please do not staple

Fold and Tape



NO POSTAGE  
NECESSARY  
IF MAILED IN THE  
UNITED STATES

# BUSINESS REPLY MAIL

FIRST-CLASS MAIL PERMIT NO. 40 ARMONK, NEW YORK

POSTAGE WILL BE PAID BY ADDRESSEE

International Business Machines Corporation  
Information Development  
Department GZW  
9000 South Rita Road  
Tucson, AZ 85744-0001



Fold and Tape

Please do not staple

Fold and Tape







Part Number: 22R5549

Printed in USA

GC26-7761-00



(1P) P/N: 22R5549



Spine information:



IBM TotalStorage SAN256B  
Director

**SAN256B Installation, Service, and User's Guide**

Service information:  
2109/M48