

IBM System Storage SAN768B-2



Installation, Service, and User Guide

Service information: 2499-816

Read Before Using

This product contains software that is licensed under written license agreements. Your use of such software is subject to the license agreements under which they are provided.

IBM System Storage SAN768B-2



Installation, Service, and User Guide

Service information: 2499-816

Note:

Before using this information and the product it supports, read the information in "Notices" on page 179.

Portions Copyright © 2011-2012 Brocade Communications Systems, Inc. All Rights Reserved.

The following paragraph does not apply to any country (or region) where such provisions are inconsistent with local law.

INTERNATIONAL BUSINESS MACHINES CORPORATION PROVIDES THIS PUBLICATION "AS IS" WITHOUT WARRANTY OF ANY KIND, EITHER EXPRESS OR IMPLIED, INCLUDING, BUT NOT LIMITED TO, THE IMPLIED WARRANTIES OF MERCHANTABILITY OR FITNESS FOR A PARTICULAR PURPOSE. Some states (or regions) do not allow disclaimer of express or implied warranties in certain transactions; therefore, this statement may not apply to you.

© Copyright IBM Corporation 2011, 2013.

US Government Users Restricted Rights – Use, duplication or disclosure restricted by GSA ADP Schedule Contract with IBM Corp.

Read this first

Summary of changes

This is the fifth edition of the *IBM System Storage SAN768B-2 Installation, Service, and User Guide*. The content changes since the last edition of this publication are noted by a vertical line placed in the left margin beside each change. Minor edits are not identified by this mark. A summary of the changes for each edition are listed below.

Fifth edition

The following changes were made in this edition:

- Addition of information regarding the need for clean optics with higher transmission speeds.
- Addition of information for tuning the system.
- Link troubleshooting information added.

Fourth edition

The following changes were made in this edition:

- Addition of Enhanced 8 Gbps 32-port blade—Feature code 3633
- Addition of Enhanced 8 Gbps 48-port blade—Feature code 3649
- Addition of FIPS tamper-proof seals—Feature code 7230
- Enhanced inter-chassis link (ICL) capability—Feature code 7873

Third edition

The following changes were made in this edition:

- Addition of FICON Accelerator and FICON with CUP Activation optional features
- Updated FOS version to 7.0.0c
- Added port speed to Encryption blade information

Second edition

The following changes were made in the second edition:

- The addition of 16 Gbps long wave length (LWL) SFP feature
- The addition of encryption, including the Encryption Blade (FS8-18)
- Updated instructions on ordering the lift tool load plate (now included with the lift tool)
- Other minor content updates

Getting help

For the latest version of your product documentation, visit the web at www.ibm.com/shop/publications/order. Search by form number or title.

IBM® Redbooks® often provide in depth information about product best practices, configurations, and more technical information. For redbooks associated with this product, enter search terms on the following website: www.redbooks.ibm.com/.

For more information about IBM SAN products, see the following website:
www.ibm.com/servers/storage/san/

For support information for this and other IBM products, see the IBM Support Portal, www.ibm.com/supportportal. Search for the product Machine type or product name.

For Fabric OS Release Notes and access to Fabric OS firmware downloads, go to the IBM Support Portal, www.ibm.com/supportportal. Search for the product Machine type or product name, and then follow links for **Downloads**. More detailed instructions are available through the **Accessing firmware updates and OS documentation updates** link on the product documentation CD that is shipped with this product.

You can also contact IBM within the United States at 1-800-IBMSERV (1-800-426-7378). For support outside the United States, you can find the service number at: www.ibm.com/planetwide/.

Visit www.ibm.com/contact for the contact information for your country or region.

For detailed information about the Fibre Channel standards, see the Fibre Channel Industry Association (FCIA) website at: www.fibrechannel.org/

For information about storage industry standards, see the Storage Networking Industry Association (SNIA) website at: www.snia.org/

Taiwan Contact Information

IBM Taiwan Product Service Contact Info:
IBM Taiwan Corporation
3F, No 7, Song Ren Rd., Taipei Taiwan
Tel: 0800-016-888

台灣IBM 產品服務聯絡方式：
台灣國際商業機器股份有限公司
台北市松仁路7號3樓
電話：0800-016-888

12c00790

How to send your comments

Your feedback is important in helping us provide the most accurate and high-quality information. If you have comments or suggestions for improving this document, send us your comments by email to starpubs@us.ibm.com. Be sure to include the following information:

- Exact publication title
- Publication form number (for example, GC26-1234-02)
- Page, table, or illustration numbers
- A detailed description of any information that should be changed

Contents

Read this first iii

Summary of changes	iii
Fifth edition	iii
Fourth edition	iii
Third edition	iii
Second edition	iii
Getting help	iii
Taiwan Contact Information	iv
How to send your comments	iv

Figures ix

Tables xi

Safety and environmental notices xiii

Safety notices and labels	xiii
Danger notices	xiii
Caution notices	xvi
Safety labels	xviii
Attention notices	xix
Rack safety	xx
Rack installation	xx
Rack relocation (19" rack)	xxi
Safety inspections	xxii
Removing ac power	xxii
External machine checks	xxii
Internal machine checks	xxii
Product recycling and disposal	xxiii

About this document xxv

Who should read this document	xxv
Product documents	xxv
Brocade documents	xxv
IBM and Brocade product matrix	xxvi
Accessibility features for SAN768B-2	xxvi

Chapter 1. Introduction 1

Overview of the SAN768B-2	1
Hardware components	3
SAN768B-2 blades	5
High availability	8
Reliability	8
Serviceability	9
Software features	9
Security	10
Network Manageability	11

Chapter 2. Installing and removing a SAN768B-2 13

Ordering the lift tool	14
World trade locations	14
United States locations	14
Installation guidelines	15
Installing a SAN768B-2 in a cabinet	16

Time required	16
Tools required	17
Parts list	18
Unpacking the SAN768B-2	19
Attaching the shelf brackets	20
Removing the chassis door and cable management comb	21
Using the lift tool, the 24-inch load plate, and the bridge tool	22
Port numbering	28
Chassis slots	29
Cable organization	30
Removing a SAN768B-2 from the cabinet	31

Chapter 3. Starting and configuring the SAN768B-2 35

Providing power to the SAN768B-2	37
Establishing a serial connection and logging on to the SAN768B-2	37
Logging in to the serial console port	38
Configuring the IP addresses	38
Logging off the serial console port and disconnecting the serial cable	39
Establishing an Ethernet connection	40
Customize a switch name	40
Customizing a chassis name	40
Setting the Domain ID	41
Setting the date and time	41
Setting the date	41
Setting the time zone	41
Synchronizing local time	42
Verifying the persistent PID feature	43
Determining installed software licenses	43
Installing transceivers and attaching cables	44
Managing cables	46
Planning for encryption (optional)	47
Configuring for encryption (optional)	48
Summary of procedure	48
Avoid double encryption	49
Verifying correct operation and backing up the configuration	49
Fabric OS firmware updates	50
Downloading and installing firmware	51
Powering off the SAN768B-2	51

Chapter 4. Monitoring system components 53

Port, application, or encryption blade status	59
Control processor blade (CP8) status	68
Core switch blade (CR16-8) status	70
Power supply status	72
Blower assembly status	73
WWN bezel and WWN card status	75

Chapter 5. Removing and installing components 79

Removing and installing the chassis door	79
Time and items required	79
Removing the chassis door	79
Removing and installing a cable management comb	80
Time and items required	80
Removing a cable management comb.	80
Installing a cable management comb	81
Removing and installing port, application, and encryption blades	81
Time and items required	82
Removing a blade	82
Installing a blade	83
Removing and installing blade filler panels.	84
Removing a filler panel	84
Installing a filler panel.	85
Removing and installing a CP8 control processor blade	85
Time and items required	86
Verifying the need for replacement	86
Recording critical SAN768B-2 information	87
Removing a control processor blade (CP8)	88
Installing a control processor blade (CP8)	89
Verifying operation of the new CP blade.	90
Downloading firmware from an FTP server.	91
Downloading firmware from a USB drive	93
Completing the CP8 blade replacement	95
Removing and installing a core switch blade (CR16-8)	95
Time and items required	96
Verifying the necessity of installation	96
Removing a core switch blade (CR16-8)	96
Installing a core switch blade (CR16-8)	97
Removing and installing a power supply	98
Time and items required	98
Removing a power supply	98
Installing a power supply	99
Removing and installing a blower assembly	100
Time and items required.	100
Removing a blower assembly	100
Installing a blower assembly	101
Removing and installing a WWN bezel and WWN card	101
Time and items required.	101
Verifying the need for replacement	102
Removing the WWN bezel and WWN card	102
Installing the WWN bezel and WWN card	103
Removing and installing transceivers	104
Time required	105
Items required	105
Removing and installing an SFP+ optical transceiver	105
Removing and installing an mSFP optical transceiver	106
Removing and replacing inter-chassis link (QSFP) cables	107
Time and items required.	109
Removing an inter-chassis link (QSFP) cable	109
Installing an ICL cable	109
Possible ICL configurations.	110

Removing and replacing the chassis	112
Verifying necessity of replacement	113
Preparing for a chassis replacement	113
Disconnecting the SAN768B-2 from the network and fabric	117
Removing components from the chassis	117
Removing and replacing the chassis from the cabinet	118
Installing components into the new chassis	118
Downloading the configuration	119
Verifying the correct operation of the system	120
Reconnecting the system to the network and fabric	121
Verifying the correct configuration of the fabric	122
Cable routing tables	123
Removing the batteries	125

Chapter 6. Installing new features . . . 129

FC3632, FC3648- Installing a 16-Gb port port blade (32 or 48 ports)	129
Time required	129
Items required	130
Procedures	130
FC3633, FC3649- Installing an Enhanced 8-Gb port blade (32 or 48 ports).	131
Time required	131
Items required	131
Procedures	131
FC3864 - Installing an 8-Gb 64-port port blade	132
Time required	132
Items required	132
Procedures	133
FC3890 - Installing an Extension Blade (FX8-24)	134
Time required	134
Items required	134
Procedures	134
FC3895 - Installing an Encryption Blade (FS8-18)	135
Time required	136
Items required	136
Procedures	136
Avoid double encryption	137
FC7230 - Installing FIPS 140-2 Level 2 tamper proof seals	137
FC7871 - Installing a QSFP and inter-chassis license	137
Time required	137
Items required	137
Procedures	137
FC7873 - Installing a QSFP and Enterprise inter-chassis license	138
Time required	138
Items required	138
Procedures	138

Appendix A. Product specifications 141

General specifications	141
System architecture	141
System size and weight	144
Facility requirements	145
Power specifications	145
Environmental requirements	147

Fibre channel port specifications	147	Electronic emission notices	182
Data transmission ranges	148	Federal Communications Commission (FCC)	
Power cords	148	Class A Statement	182
Appendix B. Application blades	151	Industry Canada Class A Emission Compliance	
FS8-18 blade	151	Statement	182
FX8-24 blade	151	Avis de conformité à la réglementation	
Appendix C. Diagnostics and		d'Industrie Canada	182
troubleshooting	153	European Union EMC Directive Conformance	
Obtaining chassis and component status	153	Statement	182
Interpreting POST and boot results	154	Germany Electromagnetic Compatibility	
POST	154	Directive	183
Boot	155	People's Republic of China Class A Electronic	
Diagnostics	155	Emission Statement	184
General troubleshooting	155	Japan Voluntary Control Council for Interference	
Link troubleshooting	157	(VCCI) Class A Statement	184
Fault isolation	158	Japan Electronics and Information Technology	
Dust, dirt, or other contaminants	159	Industries Association (JEITA) Statement	184
Best practices for minimizing link loss	159	Korea Communications Commission (KCC)	
Attenuation on LWL connections	159	Class A Statement	184
Appendix D. Tuning the system	163	Russia Electromagnetic Interference (EMI) Class	
Identifying whether you need to tune your system	163	A Statement	185
Before tuning	165	Australia and New Zealand Class A Statement	185
Appendix E. Blade port numbering	169	Taiwan Class A Electronic Emission Statement	185
Notices	179	Index	187
Trademarks	181		

Figures

1. Port side of the SAN768B-2 (sample configuration)	4	27. Chassis door	80
2. Blower (non-port) side of the SAN768B-2 (sample configuration)	5	28. Cable management comb	81
3. Parts in the 14U rack mount kit	19	29. Port and application removal and installation (FC16-48 port blade shown as example)	83
4. Left and right shelf brackets installed on the cabinet rails	20	30. Filler panel removal and installation	85
5. Installing clip or retainer nuts on the vertical cabinet rails	21	31. Removing the control processor (CP8) blade	89
6. Chassis door removal	22	32. Removing the core switch blade.	97
7. Chassis installation from rear (exhaust aisle side) of the cabinet	24	33. Power supply locations	98
8. Locking the shelf into position	25	34. Removing and installing a power supply	99
9. Attaching the port side of the chassis to the cabinet rails	26	35. Removal and replacement of the blower assembly	101
10. Aligning the chassis door with the ball studs on the chassis	27	36. WWN bezel and card removal and installation	103
11. Details of the chassis and door, showing the ball studs on the chassis and the mounting hardware on the door	28	37. Optical transceiver (SFP+) extraction tool	105
12. Cable design for the mSFP patch cables for the FC8-64 high density port blade	30	38. Installing and removing a 16 Gbps SFP+ with pull tab (shown without cable attached)	105
13. Flow of basic configuration tasks	36	39. Removing and replacing an SFP+ optical transceiver with a wire bail	106
14. Encryption configuration	49	40. Optical mSFP transceiver	107
15. FC16-32 port blade	60	41. QSFP cable and transceiver	109
16. FC16-48 port blade	61	42. QSFP cable connections for two SAN768B-2 chassis (sample configuration)	110
17. FC8-32E port blade	62	43. Core/edge ICL topology for SAN384B-2 and SAN768B-2 chassis	111
18. FC18-48E port blade	63	44. full mesh ICL topology for SAN384B-2 and SAN768B-2 chassis	112
19. FC8-64 port blade	64	45. Battery locations on the CP8 blade	126
20. FS8-18 encryption blade	65	46. Encryption blade battery location	126
21. FX8-24 extension blade.	66	47. Identifying the origin of failure	158
22. Control processor blade (CP8) components	69	48. CR16-8 core blade	170
23. Core switch blade (CR16-8), LEDs and QSFP connectors	71	49. FC16-32 port blade.	172
24. Power supply LEDs.	73	50. FC16-48 port blade.	173
25. Blower assembly LEDs.	74	51. FC8-32E port blade	174
26. LEDs on the WWN card and bezel.	77	52. FC8-48E port blade	175
		53. FC8-64 port blade	176
		54. FS8-18 encryption blade	177
		55. FX8-24 extension blade	178

Tables

1. Brocade and IBM product and model number matrix	xxvi	16. Sample cable routing table for SAN768B-2	123
2. Blades available for the SAN768B-2	5	17. Cable routing table for SAN768B-2 (64 ports shown).	123
3. Installation tasks, time, and items required	17	18. General specifications	141
4. Items supplied with the 14U rack mount kit	18	19. System architecture	141
5. Port and application blades available on the SAN768B-2.	28	20. System sizes and weights	144
6. Port, application, and encryption blade LED descriptions	67	21. System FRU weights	144
7. CP8 blade LED descriptions	70	22. Power specifications	145
8. CR16-8 blade LED descriptions	71	23. Power demands per component	146
9. Power supply LED descriptions.	73	24. Environmental requirements	147
10. Blower assembly LED descriptions.	74	25. Supported optics, speeds, cables, and distances	148
11. Messages that may indicate WWN card failure	75	26. Environmental status and maintenance commands	154
12. WWN LED patterns.	76	27. Troubleshooting.	155
13. Steps for upgrading through multiple versions of Fabric OS	91	28. Specifications of LWL 10km transceivers	160
14. ICL connector port LEDs.	108	29. Maximum receive power of 2 Gbps LWL SFPs	160
15. Critical information checklist example	114	30. External port to slotShow port mapping for CR16-8 core blades.	171

Safety and environmental notices

This section contains information about:

- “Safety notices and labels”
- “Rack safety” on page xx
- “Safety inspections” on page xxii
- “Product recycling and disposal” on page xxiii

Safety notices and labels

When using this product, observe the danger, caution, and attention notices contained in this guide. The notices are accompanied by symbols that represent the severity of the safety condition. The danger and caution notices are listed in numerical order based on their IDs, which are displayed in parentheses, for example (D004), at the end of each notice. Use this ID to locate the translation of these danger and caution notices in the Safety Notices publication that is shipped with this product.

The following notices and statements are used in IBM documents. They are listed below in order of increasing severity of potential hazards. Follow the links for more detailed descriptions and examples of the danger, caution, and attention notices in the sections that follow.

- **Note:** These notices provide important tips, guidance, or advice.
- **“Attention notices” on page xix:** These notices indicate potential damage to programs, devices, or data.
- **“Caution notices” on page xvi:** These statements indicate situations that can be potentially hazardous to you.
- **“Danger notices”:** These statements indicate situations that can be potentially lethal or extremely hazardous to you. Safety labels are also attached directly to products to warn of these situations.
- In addition to these notices, “Safety labels” on page xviii may be attached to the product to warn of potential hazards.

Danger notices

A danger notice calls attention to a situation that is potentially lethal or extremely hazardous to people. A lightning bolt symbol accompanies a danger notice to represent a dangerous electrical condition. Read and comply with the following danger notices before installing or servicing this device.



DANGER

To prevent a possible shock from touching two surfaces with different protective ground (earth), use one hand, when possible, to connect or disconnect signal cables. (D001)



DANGER

Overloading a branch circuit is potentially a fire hazard and a shock hazard under certain conditions. To avoid these hazards, ensure that your system electrical requirements do not exceed branch circuit protection requirements. Refer to the information that is provided with your device or the power rating label for electrical specifications. (D002)



DANGER

If the receptacle has a metal shell, do not touch the shell until you have completed the voltage and grounding checks. Improper wiring or grounding could place dangerous voltage on the metal shell. If any of the conditions are not as described, STOP. Ensure the improper voltage or impedance conditions are corrected before proceeding. (D003)



DANGER

An electrical outlet that is not correctly wired could place hazardous voltage on metal parts of the system or the devices that attach to the system. It is the responsibility of the customer to ensure that the outlet is correctly wired and grounded to prevent an electrical shock. (D004)

A general electrical danger notice provides instructions on how to avoid shock hazards when servicing equipment. Unless instructed otherwise, follow the procedures in the following danger notice.



DANGER

When working on or around the system, observe the following precautions:

Electrical voltage and current from power, telephone, and communication cables are hazardous. To avoid a shock hazard:

- Connect power to this unit only with the IBM provided power cord. Do not use the IBM provided power cord for any other product.
- Do not open or service any power supply assembly.
- Do not connect or disconnect any cables or perform installation, maintenance, or reconfiguration of this product during an electrical storm.
- The product might be equipped with multiple power cords. To remove all hazardous voltages, disconnect all power cords.
- Connect all power cords to a properly wired and grounded electrical outlet. Ensure that the outlet supplies proper voltage and phase rotation according to the system rating plate.
- Connect any equipment that will be attached to this product to properly wired outlets.
- When possible, use one hand only to connect or disconnect signal cables.
- Never turn on any equipment when there is evidence of fire, water, or structural damage.
- Disconnect the attached power cords, telecommunications systems, networks, and modems before you open the device covers, unless instructed otherwise in the installation and configuration procedures.
- Connect and disconnect cables as described below when installing, moving, or opening covers on this product or attached devices.

To Disconnect:

1. Turn off everything (unless instructed otherwise).
2. Remove the power cords from the outlets.
3. Remove the signal cables from the connectors.
4. Remove all cables from the devices.

To Connect:

1. Turn off everything (unless instructed otherwise).
2. Attach all cables to the devices.
3. Attach the signal cables to the connectors.
4. Attach the power cords to the outlets.
5. Turn on the devices.

(D005)

The weight of the SAN cabinet (2109-C36) with two SAN768B-2s is greater than 227 kg (500 lb), and has a fully loaded capacity of 816 kg (1795 lb). Under these conditions, the following statement and notice apply.

Delivery and subsequent transportation of the equipment

The customer should prepare his environment to accept the new product based on the installation planning information provided, with assistance from an IBM Installation Planning Representative (IPR) or IBM authorized service provider. In anticipation of the equipment delivery, the final installation site should be prepared in advance such that professional movers/riggers can transport the equipment to the final installation site within the computer room. If for some reason, this is not possible at the time of delivery, the customer will need to make arrangements to have professional movers/riggers return to finish the transportation at a later date. Only professional movers/riggers should transport the equipment. The IBM authorized service provider will only perform minimal frame repositioning within the computer room, as needed, to perform required service actions. The customer is also responsible for using professional movers/riggers in the case of equipment relocation or disposal.









DANGER

Heavy equipment—personal injury or equipment damage might result if mishandled. (D006)

Caution notices

A caution notice calls attention to a situation that is potentially hazardous to people because of some existing condition. A caution notice can be accompanied by different symbols, as in the examples below:

If the symbol is...	It means....
	A hazardous electrical condition with less severity than electrical danger.
	A generally hazardous condition not represented by other safety symbols.
	A specification of product weight that requires safe lifting practices. The weight range of the product is listed below the graphic, and the wording of the caution varies, depending on the weight of the device.
	A potential hazard of pinching the hand or other body parts between parts.
	A hazardous condition due to moving parts nearby.
	A hazardous condition due to the use of a laser in the product. Laser symbols are always accompanied by the classification of the laser as defined by the U. S. Department of Health and Human Services (for example, Class I, Class II, and so forth).

Read and comply with the following caution notices before installing or servicing this device.



CAUTION:

Energy hazard present. Shorting may result in system outage and possible physical injury. Remove all metallic jewelry before servicing. (C001)

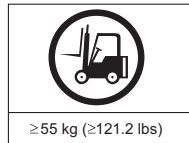

svc00169

CAUTION:

The weight of this part or unit is more than 55 kg (121.2 lb). It takes specially trained persons, a lifting device, or both to safely lift this part or unit. (C011)

>55kg (121.2 lb)



CAUTION:

The system contains circuit cards, assemblies, or both that may contain lead solder. To avoid the release of lead (Pb) into the environment, do not burn. Discard the circuit card as instructed by local regulations. (C014)



CAUTION:

This product is equipped with a 3-wire (two conductors and ground) power cable and plug. Use this power cable with a properly grounded electrical outlet to avoid electrical shock. (C018)



Class I

CAUTION:

This product might contain one or more of the following devices: CD-ROM drive, DVD-ROM drive, DVD-RAM drive, or laser module, which are Class 1 laser products. Note the following information:

- Do not remove the covers. Removing the covers of the laser product could result in exposure to hazardous laser radiation. There are no serviceable parts inside the device.
- Use of the controls or adjustments or performance of procedures other than those specified herein might result in hazardous radiation exposure.

(C026)



CAUTION:

The power-control button on the device does not turn off the electrical current supplied to the device. The device might also have more than one connection to dc power. To remove all electrical current from the device, ensure that all connections to dc power are disconnected at the dc power input terminals. (C031)



CAUTION:

Servicing of this product or unit is to be performed by trained service personnel only. (C032)

CAUTION:

For CA residents only: IBM recommends installing this product in a room size of 62 cubic meters (2190 cubic feet) or larger at 0.4 ACH ventilation rate to reduce the concentrations of any chemicals emitted by the product.

Safety labels

As an added precaution, safety labels are often installed directly on products or product components to warn of potential hazards. These can be either danger or caution notices, depending upon the level of the hazard.

The actual product safety labels may differ from these sample safety labels:



DANGER

Hazardous voltage, current, or energy levels are present inside any component that has this label attached. Do not open any cover or barrier that contains this label. (L001)



DANGER

Rack-mounted devices are not to be used as a shelf or work space. (L002)

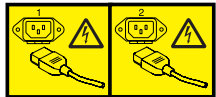

DANGER

Multiple power cords. The product might be equipped with multiple power cords. To remove all hazardous voltages, disconnect all power cords. (L003)



DANGER

Hazardous voltage present. Voltages present constitute a shock hazard, which can cause severe injury or death. (L004)



CAUTION:

Hazardous energy present. Voltages with hazardous energy might cause heating when shorted with metal, which might result in splattered metal, burns, or both. (L005)

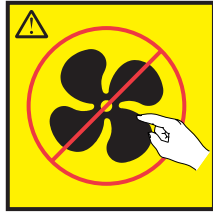

CAUTION:
Hazardous moving parts nearby (L008)



CAUTION:
Pinch hazard. (L012)

SJ000752

Attention notices

An attention notice indicates the possibility of damage to a program, device, or system, or to data. An exclamation point symbol may accompany an attention notice, but is not required. A sample attention notice follows:

Attention: Do not bend a fibre cable to a radius less than 5 cm (2 in.); you can damage the cable. Tie wraps are not recommended for optical cables because they can be easily overtightened, causing damage to the cable.

ESD precautions

Attention: Many of the field replaceable units (FRUs) are sensitive to electrostatic discharge (ESD), and can potentially be damaged by improper handling. Wear a wrist grounding strap connected to chassis ground (if the SAN768B-2 is plugged in) or a bench ground. Store all ESD-sensitive components in antistatic packaging.

Rack safety

Rack installation

DANGER

Observe the following precautions when working on or around your IT rack system:

- Heavy equipment—personal injury or equipment damage might result if mishandled.
- Always lower the leveling pads on the rack cabinet.
- Always install stabilizer brackets on the rack cabinet.
- To avoid hazardous conditions due to uneven mechanical loading, always install the heaviest devices in the bottom of the rack cabinet. Always install servers and optional devices starting from the bottom of the rack cabinet.
- Rack-mounted devices are not to be used as shelves or work spaces. Do not place objects on top of rack-mounted devices.



- Each rack cabinet might have more than one power cord. Be sure to disconnect all power cords in the rack cabinet when directed to disconnect power during servicing.
- Connect all devices installed in a rack cabinet to power devices installed in the same rack cabinet. Do not plug a power cord from a device installed in one rack cabinet into a power device installed in a different rack cabinet.
- An electrical outlet that is not correctly wired could place hazardous voltage on the metal parts of the system or the devices that attach to the system. It is the responsibility of the customer to ensure that the outlet is correctly wired and grounded to prevent an electrical shock.

(R001 part 1 of 2)

CAUTION:

- Do not install a unit in a rack where the internal rack ambient temperatures will exceed the manufacturer's recommended ambient temperature for all your rack-mounted devices.
- Do not install a unit in a rack where the air flow is compromised. Ensure that air flow is not blocked or reduced on any side, front, or back of a unit used for air flow through the unit.
- Consideration should be given to the connection of the equipment to the supply circuit so that overloading of the circuits does not compromise the supply wiring or overcurrent protection. To provide the correct power connection to a rack, refer to the rating labels located on the equipment in the rack to determine the total power requirement of the supply circuit.
- *(For sliding drawers)* Do not pull out or install any drawer or feature if the rack stabilizer brackets are not attached to the rack. Do not pull out more than one drawer at a time. The rack might become unstable if you pull out more than one drawer at a time.
- *(For fixed drawers)* This drawer is a fixed drawer and must not be moved for servicing unless specified by the manufacturer. Attempting to move the drawer partially or completely out of the rack might cause the rack to become unstable or cause the drawer to fall out of the rack.

(R001 part 2 of 2)

Rack relocation (19" rack)

CAUTION:

Removing components from the upper positions in the rack cabinet improves rack stability during relocation. Follow these general guidelines whenever you relocate a populated rack cabinet within a room or building:

- Reduce the weight of the rack cabinet by removing equipment starting at the top of the rack cabinet. When possible, restore the rack cabinet to the configuration of the rack cabinet as you received it. If this configuration is not known, you must do the following:
 - Remove all devices in the 32U position and above.
 - Ensure that the heaviest devices are installed in the bottom of the rack cabinet.
 - Ensure that there are no empty U-levels between devices installed in the rack cabinet below the 32U level.
 - If the rack cabinet you are relocating is part of a suite of rack cabinets, detach the rack cabinet from the suite.
 - Inspect the route that you plan to take when moving the rack to eliminate potential hazards.
 - Verify that the route that you choose can support the weight of the loaded rack cabinet. Refer to the documentation that came with your rack cabinet for the weight of a loaded rack cabinet.
 - Verify that all door openings are at least 760 x 2030 mm (30 x 80 in.).
 - Ensure that all devices, shelves, drawers, doors, and cables are secure.
 - Ensure that the four leveling pads are raised to their highest position.
 - Ensure that there is no stabilizer bracket installed on the rack cabinet during movement.
 - Do not use a ramp inclined at more than 10 degrees.
 - Once the rack cabinet is in the new location, do the following:
 - Lower the four leveling pads.
 - Install stabilizer brackets on the rack cabinet.
 - If you removed any devices from the rack cabinet, repopulate the rack cabinet from the lowest position to the highest position.
 - If a long distance relocation is required, restore the rack cabinet to the configuration of the rack cabinet as you received it. Pack the rack cabinet in the original packaging material, or equivalent. Also, lower the leveling pads to raise the casters off of the pallet and bolt the rack cabinet to the pallet.

(R002)

Safety inspections

Perform the following safety checks to identify unsafe conditions. Be cautious of potential safety hazards that are not covered in the safety checks. If unsafe conditions are present, determine how serious the hazards are and whether you should continue before you correct the problem.

Removing ac power

Perform the following steps to remove the alternating current (ac) power:

1. Perform a controlled system shutdown.
2. Set the power switch on the product to the off position.
3. Disconnect the power cables from the power source.

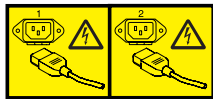

DANGER

Multiple power cords. (L003)

External machine checks

Perform the following external machine checks:

1. Verify that all external covers are present and are not damaged.
2. Ensure that all latches and hinges are in correct operating condition.
3. Check the power cable for damage.
4. Check the external signal cable for damage.
5. Check the cover for sharp edges, damage, or alterations that expose the internal parts of the device.
6. Check that any unused serial ports are covered for dust and ESD protection. The cover should be kept on the serial port whenever it is not being used.
7. Correct any problems that you find.

Internal machine checks

Perform the following internal machine checks:

1. Check for any non-IBM changes that might have been made to the machine. If any are present, obtain the "Non-IBM Alteration Attachment Survey" form, number R009, from the IBM branch office. Complete the form and return it to the branch office.
2. Check the condition of the inside of the machine for:
 - Metal or other contaminants
 - Indications of water or other fluid
 - Fire
 - Smoke damage
3. Check for any obvious mechanical problems, such as loose components.
4. Check any exposed cables and connectors for wear, cracks, or pinching.

Product recycling and disposal

Refer to the *IBM Systems Environmental Notices and User Guide (Z125-5823)* on the CD shipped with the product for translated environmental statements and information regarding product recycling and disposal. This document may be provided either in printed version or on a documentation CD. See “Removing the batteries” on page 125 for battery removal instructions, if needed to meet environmental regulations.

About this document

This document describes how to install and service the IBM System Storage[®] SAN768B-2 fabric backbone. Throughout this document, the product is referred to as the *SAN768B-2*, or more generically as *system*, *device*, or *chassis*, where appropriate. This document includes information specific to the SAN768B-2 running Fabric OS version 7.1.1 and later. For information about a Fabric OS version other than 7.1.1, refer to the documentation specific to your Fabric OS version.

Note: 7.0.0c is the latest FICON supported release.

The sections that follow provide information about:

- “Who should read this document”
- “Product documents”
- “Brocade documents”

Who should read this document

This document is intended for trained service representatives who are responsible for installing and servicing the SAN768B-2, and for network administrators responsible for maintaining and using the SAN768B-2.

Product documents

The following documents contain information related to this product. The documentation may be printed material, on the documentation CD that is shipped with the product, or available on the web through the IBM Support Portal or IBM Publications Center.

- *IBM System Storage SAN768B-2 Installation, Service, and User Guide*, GA32-0893 (this document, which is also available in accessible HTML format on the documentation CD).
- Safety Notices
- *IBM Systems Environmental Notices and User Guide*, Z125-5823
- IBM Warranty
- *Implementing an IBM/Brocade SAN with 8 Gbps Directors and Switches*, (an IBM Redbook), SG24-6116

Note: This publication was written for earlier products, but many of the procedures still apply.

- *IBM System Storage FIPS 140-2 Security Seal Application Procedures* (GA32-2220-00), available online only for this optional feature.

Brocade documents

IBM switches use software licensed from Brocade Communications Systems, Inc. You can find information related to the software that supports the SAN768B-2 in the following documents on the CD-ROM supplied with this product. More recent versions of the Fabric Operating System (FOS) documentation may be available to

match the version of FOS that you have installed. The publication CD includes information on how to locate and download the latest versions of FOS documentation and firmware updates.

Brocade Fabric OS

- *Fabric OS Administrator's Guide*
- *Fabric OS Command Reference*
- *Fabric OS MIB Reference*
- *Fabric OS Message Reference*
- *Fabric OS Troubleshooting and Diagnostics Guide*
- *Fabric OS FCIP Administrator's Guide*
- *Fabric OS Encryption Administrator's Guide Supporting Tivoli Key Lifecycle Manager (TKLM) Environments*
- *FICON Administrator's Guide*

Brocade Fabric OS optional features

- *Fabric Watch Administrator's Guide*
- *Web Tools Administrator's Guide*

IBM and Brocade product matrix

When you use any of the Brocade documents, such as Fabric Operating System (FOS) publications, you will notice that the model numbers reflect the corresponding Brocade products. Table 1 provides a product matrix for you to use to correlate the Brocade products and models to the IBM product names and machine types and model numbers. Products withdrawn from marketing are not listed.

Table 1. Brocade and IBM product and model number matrix

Brocade product name	IBM product name	IBM machine type and model number
Brocade 6520	SAN96B-5	2498 Models F96 and N96
Brocade 6505	SAN24B-5	2498 Model F24, 249824G
Brocade 6510	SAN48B-5	2498 Model F48
Brocade DCX 8510-4	SAN384B-2	2499 Model 416
Brocade DCX 8510-8	SAN768B-2	2499 Model 816
Brocade DCX-4S	SAN384B	2499 Model 192
Brocade DCX	SAN768B	2499 Model 384
Brocade Encryption Switch	SAN32B-E4	2498 Model E32
Brocade 7800	SAN06B-R	2498 Model R06
Brocade 5300	SAN80B-4	2498 Model B80
Brocade 300	SAN24B-4	2498 Models B24 and 24E

Accessibility features for SAN768B-2

Accessibility features help users with restricted mobility or limited vision successfully use information technology products. IBM strives to provide products with usable access for everyone, regardless of age or ability. This product uses standard Windows navigation keys.

Accessibility features

Use and operation of this device is accomplished primarily through external devices which may provide different accessibility features.

The following list includes the major accessibility features in the SAN768B-2 either directly or through external devices or interfaces:

- Keyboard-only operation
- Interfaces that are commonly used by screen readers
- Keys that are discernible by touch but do not activate just by touching them
- Industry-standard devices for ports and connectors
- The attachment of alternative input and output devices

Keyboard navigation

This product uses standard Microsoft Windows navigation keys. You can navigate the software and the product documentation from the keyboard by using the shortcut keys for your browser or screen-reader software. See your browser or screen-reader software Help for a list of shortcut keys that it supports.

Vendor software

The SAN768B includes certain vendor software that is not covered under the IBM license agreement. IBM makes no representation about the accessibility features of these products. Contact the vendor for the accessibility information about its products.

Related accessibility information

You can view the publications for the SAN768B-2 in Adobe Portable Document Format (PDF) using the Adobe Acrobat Reader. The PDFs are provided on a CD that is packaged with the product. An accessible HTML version of this document is also included on the documentation CD for this product.

IBM and accessibility

See the IBM Human Ability and Accessibility Center for more information about the commitment that IBM has to accessibility: www.ibm.com/able.

Chapter 1. Introduction

This chapter introduces the features and components of the IBM System Storage SAN768B-2 fabric backbone. Throughout the remainder of this document, the product will be referred to as the *SAN768B-2*, or more generically as *system*, *device*, or *chassis*, where appropriate. This chapter contains the following information:

- “Overview of the SAN768B-2”
- “Hardware components” on page 3
- “High availability” on page 8
- “Reliability” on page 8
- “Serviceability” on page 9
- “Software features” on page 9

Overview of the SAN768B-2

The SAN768B-2 is part of IBM's industry-leading backbone-class product line, a highly robust class of network switching platform that combines breakthrough performance, scalability, and energy efficiency with long-term investment. Supporting open systems and System z[®], SAN backbones are designed to address the data growth and application demands of evolving enterprise data centers, achieve server, SAN, and data center consolidation, and reduce infrastructure and administrative costs. The IBM backbone-class product line provides the most reliable, scalable, high performance foundation for private cloud storage and highly virtualized environments. They are designed to increase business agility by adapting to dynamic growth and change, providing high availability access to information, and reducing infrastructure and administrative costs.

Key features of the SAN768B-2 include:

- Up to 384 16-Gbps external ports in a single chassis, enabling high density SAN configurations with reduced footprint.
- Support for 2, 4, 8, and 16 Gbps auto-sensing Fibre Channel ports. Trunking technology groups up to eight ports to create high performance 64-Gbps ISL trunks between switches.
- Support for 10 Gbps FC-type SFPs in 16 Gbps port blades only, and also supports 10 GbE SFPs in the FX8-24 extension blades. The two types of SFPs are not interchangeable.
- The 10 Gbps ports can be configured manually on only the first eight ports of the 16 Gbps port blades.
- Support for all of the application, port blade, and control processor (CP) blades supported in the SAN384B-2 (with the exception of the Core Switch Blade), providing flexible system configurations and fewer types of new blades.
- Beginning with Fabric OS v7.0.1, up to nine chassis can be connected with the use of 4x16 Gbps quad SFP (QSFP) inter-chassis links (ICLs). Fabric OS v7.0.0 permits up to six chassis to be linked.
- Support for high-performance port blades running at 2, 4, 8, 10, or 16 Gbps, enabling flexible system configuration.

- Redundant and hot-swappable control processor and core switch blades, power supplies, blower assemblies, and WWN cards that enable a high availability platform and enable nondisruptive software upgrades for mission-critical SAN applications.
- Universal ports that self-configure as E_Ports, F_Ports, EX_Ports and M_Ports (mirror ports). 10 Gbps ports are E_Ports only.
- Diagnostic port (D_Port) functionality.
- In-flight data cryptographic (encryption/decryption) and data compression capabilities through the 16 Gbps port blades.
- Fibre Channel over IP (FCIP) functionality through the FX8-24 blade.

Attention: This product is not intended to be connected directly or indirectly by any means whatsoever to interfaces of public telecommunications networks.

Hardware components

The SAN768B-2 features a modular and scalable mechanical construction that allows a wide range of flexibility in installation, fabric design, and maintenance. The chassis may be mounted with the cables facing the front of the equipment rack or to the rear, and consists of the following:

- Up to eight hot-swappable port blade assemblies can be configured in a single chassis, delivering up to 384 16 Gbps Fibre Channel ports.
- Two slots for control processor blades (CP8):
 - A single active CP8 blade can control all 384 ports in the chassis.
 - The standby CP8 blade assumes control of the SAN768B-2 if the active CP fails.
- Two slots for core switch blades (CR16-8):
 - CR16-8 blade interconnects all port blades
 - Inter-chassis link (ICL) connectors to connect to as many as nine neighboring chassis (with FOS 7.0.1). Six chassis can be connected with FOS v7.0.0.
 - Both CR16-8 blades are active
- Modular hot-swappable port blades:
 - 64-port, 8-Gbps blades (FC8-64)
 - 32-port, 8-Gbps blades (FC8-32E)
 - 48-port, 8-Gbps blades (FC8-48E)
 - 32-port, 16-Gbps blades (FC16-32)
 - 48-port, 16-Gbps blades (FC16-48)
- Modular hot-swappable application blades:
 - FX8-24: 24-port (12 FC, 10 GbE, 2 10GbE) FCIP extension blade enabling long distance communication over existing IP infrastructure.
- Modular hot-swappable encryption blades:
 - FS8-18: 16-port 8 Gbps, up to 4 blades per chassis, supporting in-flight data cryptographic (encryption/decryption) and data-compression capabilities.
- Modular hot-swappable field replaceable units (FRUs):
 - Three blower assemblies
 - Up to four power supplies
 - Two WWN cards
 - Blades use small form-factor pluggable (SFP+, and mSFP) optical transceivers. SFP+ and mSFP transceivers support speeds of 2, 4, 8, 10, or 16 Gbps.

Note: The 8-Gbps SFP+s and mSFPs auto-negotiate at 2, 4, and 8 Gbps. The 16-Gbps SFP+s auto-negotiate at 4, 8, and 16 Gbps. The 10 Gbps speeds must be manually set and require special 10 Gbps SFP+ transceivers.

 - QSFP-based inter-chassis link (ICL) cabling running at 64 Gbps (four 16 Gbps clustered in a single quad connector and cable).
- Blades are serviced from the port side of the SAN768B-2. Blowers, power supplies, and power cables are serviced from the nonport side.
- World Wide Name (WWN) cards on the nonport side, to maintain chassis-specific information such as WWNs, IP addresses, and summary status information of each port blade and power supply through LEDs
- Constant intake and FRU temperature monitoring
- Redundant AC primary power connections to ensure high availability. Each power supply has its own connector.

Note: Airflow in the SAN768B-2 is from the non-port (non-cable) side to the port (cable) side and out the exhaust vent.
 Figure 1 shows a sample configuration of the port side of the SAN768B-2, with the chassis door removed.

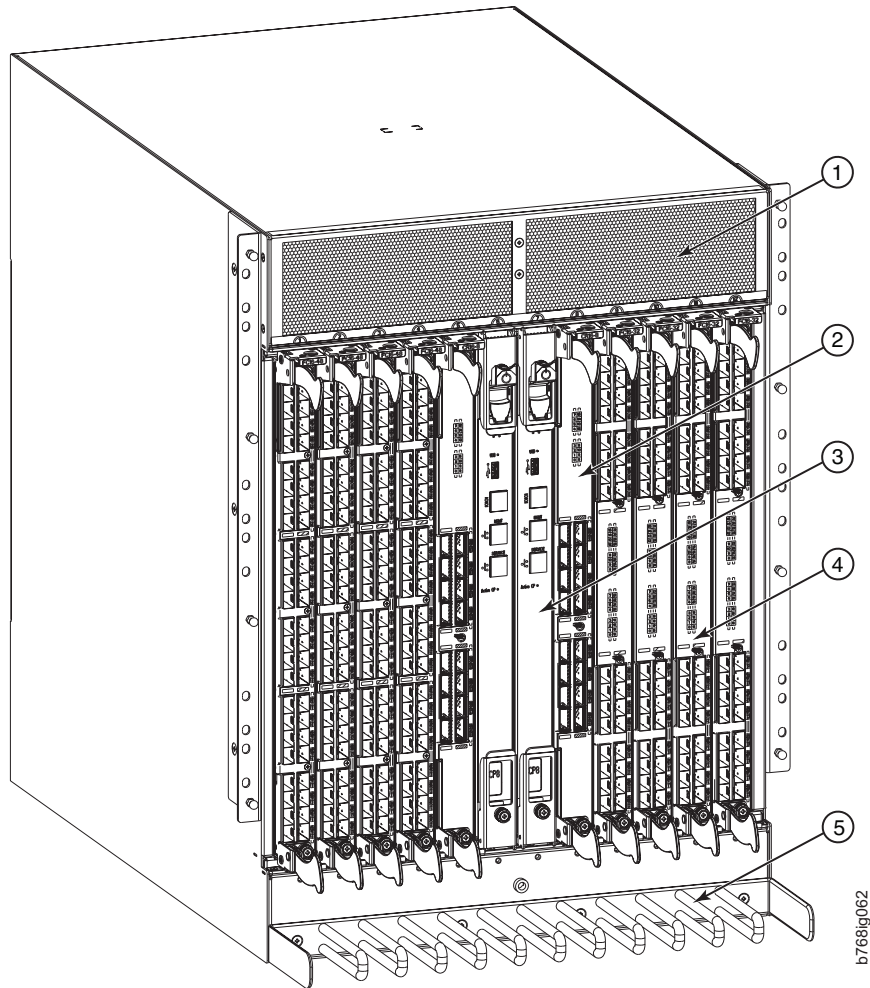

Figure 1. Port side of the SAN768B-2 (sample configuration)

- | | | | |
|----------|-------------------------------|----------|-----------------------|
| 1 | Exhaust vent | 4 | FC16-32 port blade |
| 2 | Core switch blade (CR16-8) | 5 | Cable management comb |
| 3 | Control processor blade (CP8) | | |

Figure 2 on page 5 shows a sample configuration of the non-port side of the SAN768B-2 with 4 power supplies.

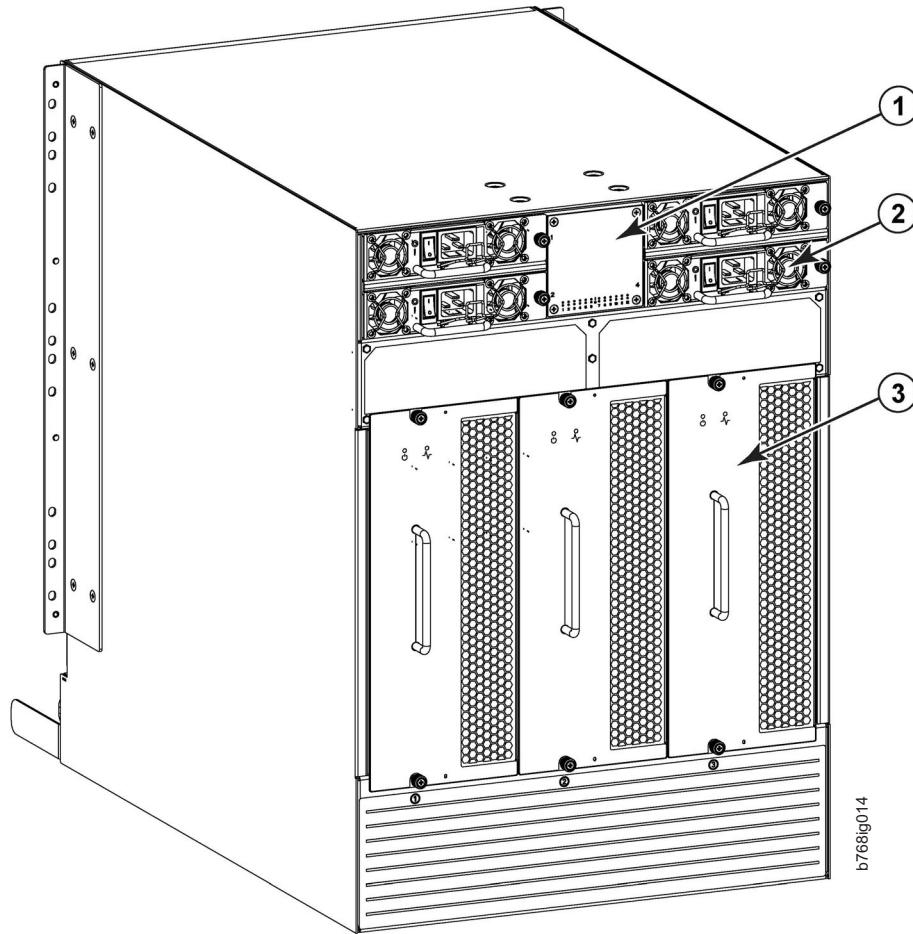

Figure 2. Blower (non-port) side of the SAN768B-2 (sample configuration)

- | | |
|--|---------------------------------|
| <p>1 WWN bezel</p> <p>2 Power supply</p> | <p>3 Blower assembly</p> |
|--|---------------------------------|

SAN768B-2 blades

Table 2 summarizes the port, application, control processor, and core switch blades that are available for the SAN768B-2.

Table 2. Blades available for the SAN768B-2

Description	Feature Code	Name	Function
Control processor blade	N/A	CP8	The CP8 blade contains the control plane for the chassis. There are two CP8 blades for redundancy. This control processor blade is compatible with the SAN768B-2, SAN384B-2, SAN768B, and SAN384B.

Table 2. Blades available for the SAN768B-2 (continued)

Description	Feature Code	Name	Function
Core switch blade	N/A	CR16-8	The CR16-8 blade contains the ASICs for switching between port blades. Every port blade connects to every core switch blade. There can be up to 384 16-Gbps (512 8-Gbps) total ports for port blades. Each core switch blade connects to 128 backplane ports. Core switch blades have additional front port connectivity to connect multiple chassis and backplane connections for the storage server blade. This core switch blade is compatible only with the SAN768B-2.
32-port 16-Gbps port blade	FC3632	FC16-32	A 32-port port blade supporting 2, 4, 8, 10, and 16 Gbps Fibre Channel port speeds. The blade also supports port-based in-flight encryption / decryption and compression / decompression. This port blade is compatible with the SAN384B-2 and SAN768B-2.
48-port 16-Gbps port blade	FC3648	FC16-48	A 48-port Brocade port blade supporting 2, 4, 8, 10, and 16 Gbps Fibre Channel port speeds. The blade also supports port-based in-flight encryption / decryption and compression / decompression. This port blade is compatible with the SAN384B-2 and SAN768B-2.

Table 2. Blades available for the SAN768B-2 (continued)

Description	Feature Code	Name	Function
32-port 8-Gbps port blade	FC3633	FC8-32E	A 32-port port blade supporting 2, 4, and 8 Gbps Fibre Channel port speeds. This port blade is compatible with the SAN384B-2 and SAN768B-2. This blade requires Fabric OS v7.0.1 or later to run in this chassis.
48-port 8-Gbps port blade	FC3649	FC8-48E	A 48-port port blade supporting 2, 4, and 8 Gbps Fibre Channel port speeds. This port blade is compatible with the SAN384B-2 and SAN768B-2. This blade requires Fabric OS v7.0.1 or later to run in this chassis.
64-port 8-Gbps port blade	FC3864	FC8-64	A 64-port port blade supporting 2, 4, and 8 Gbps port speeds with mSFPs. This port blade is compatible with the SAN768B-2, SAN384B-2, SAN768B, and SAN384B
FCIP extension blade	FC3890	FX8-24	The FX8-24 blade enables FCIP functionality over existing IP infrastructure. It has 12 FC ports, ten 1 GbE ports, and two 10 GbE ports available. This application blade is compatible with the SAN768B-2, SAN384B-2, SAN768B, and SAN384B

Table 2. Blades available for the SAN768B-2 (continued)

Description	Feature Code	Name	Function
Encryption blade	FC3895	FS8-18	The FS8-18 blade enables data cryptographic (encryption/ decryption) and data-compression capabilities for data-at-rest. It has 16 Fibre Channel 8 Gbps optical SFP ports. This application blade is compatible with the SAN768B-2, SAN384B-2, SAN768B, and SAN384B

High availability

The following features contribute to the SAN768B-2's high-availability design:

- Redundant, hot-swappable FRUs, including blades, power supplies, blowers, WWN cards
- Enhanced data integrity on all data paths
- Fabric Shortest Path First (FSPF) rerouting around failed links
- Integration with Simple Network Management Protocol (SNMP) managers
- Automatic control processor failover
- Nondisruptive "hot" software code loads and activation
- Easy configuration, save, and restore

The high-availability software architecture of the SAN768B-2 provides a common framework for all applications that reside on the system, allowing global and local status to be maintained through any component failure. High-availability elements consist of the High Availability Manager, the heartbeat, the fault/health framework, the replicated database, initialization, and software upgrade.

The High Availability Manager controls access to the standby control processor, facilitates software upgrades, prevents extraneous CP failover activity, closes and flushes streams as needed, provides flow control and message buffering, and supports a centralized active and standby state.

Reliability

The SAN768B-2 uses the following error detection and correction mechanisms to ensure reliability of data:

- Error Detection and Correction over main control processor memory
- Error Detection and Correction mechanism, which checks for encoder errors and fault isolation (EDFI), such as cyclic redundancy checking (CRC), parity checking, checksum, and illegal address checking
- Power-on self test (POST)
- Dual control processors that enable hot, nondisruptive fast firmware upgrades

- One serial port and two Ethernet ports on each control processor for management and for service. Offline control processor diagnostics and remote diagnostics simplify troubleshooting. The standby control processor monitors diagnostics to ensure the system is operational should a failover be necessary.
- Bus monitoring and control of blades and other field-replaceable units (FRUs).

Serviceability

The SAN768B-2 provides the following features to enhance and ensure serviceability:

- Modular design with hot-swappable components
- Flash memory that stores two firmware images per control processor
- USB port on control processor blades for most tasks that formerly required an FTP/SCP server, including software and firmware upgrades
- Nonvolatile random-access memory (NVRAM), containing the OEM serial number, IBM serial number, revision information, and part number information
- Background health-check daemon
- Memory scrubber, self test, and bus ping to determine if a bus is not functioning
- RASlog messages
- SMI-S compliant
- Hardware and software watchdog timers.
- Status LEDs
- Predictive diagnostics analysis through Fabric Watch
- SNMP (including version 3) integration with higher-layer managers

Software features

The Fabric OS allows any Fibre Channel-compliant device to attach to the switches as long as it conforms to the device login, name service, and related Fibre Channel standards. Each operating environment requires that a Fibre Channel host bus adapter (HBA) be available with a standards-compliant driver for correct interface to the fabric.

Fabric OS consists of a set of embedded applications running on top of an embedded Linux operating system kernel. Some of these applications include:

- Name server
- Alias server
- Zone server
- Simple Network Management Protocol (SNMP) agent
- SMI-S compliant API
- Syslog auditing
- RCS (Reliable Commit Service)
- NTP
- Tasks to manage address assignment, routing, link initialization, fabric initialization, link shutdown, chassis shutdown, and the user interface.
- FICON® with CUP Activation (optional feature), providing in-band management of the supported SAN b-type switch and director products by system automation for z/OS from IBM System z10 EC, z10 BC, z9 EC, z9 BC, zSeries 990, 900, 890, and 880 servers.

- FICON Accelerator (optional feature), which is designed to support secure high-speed data movement between multiple locations

Security

The list below highlights some of the key security features available for the SAN384B-2 and for other switches running Fabric OS 7.0.1 or later.

- DH-CHAP
- SSHv2 (using AES, 3DES, RSA)
- HTTPS (using AES)
- SNMPv3
- FC-SP
- Secure RPC
- Secure file copy (SCP)
- Telnet disable
- Telnet timeout
- IP filters (block listeners)
- Secure passwords (centralized control through RADIUS/CHAP)
- Multiple user accounts (MUAs). Up to 255.
- Role-based access controls (RBACs)
- Administrative domains/Virtual fabrics
- Boot PROM password reset
- Password hardening policies
- Upfront login in Web Tools
- Login banner
- Monitoring of attempted security breaches (through audit logging)
- Monitoring of attempted security breaches (through Fabric Watch Security Class)
- Fibre Channel security policies: DCC and SCC
- Trusted Switch (FCS) for central security management
- Management access controls (SNMPv3, Telnet, FTP, serial port, front panel)
- Hardware-enforced zoning by WWN, domain/port ID, or both
- Default zoning
- RSCN suppression and aggregation
- Configurable RSCN suppression by port
- NTPv3 (to synchronize timestamps)
- Event auditing
- Change tracking
- Firmware change alerts in Fabric Manager
- Persistent port disable
- Persistent domain ID
- E_Port disable

Installation of the optional Federal Information Processing Standards 140-2 (FIPS 140-2) security seals to the SAN384B-2 chassis, blades, and other components is available through Feature Code 7230. The *IBM System Storage FIPS 140-2 Security Seal Application Procedures* (GA32-2220-00) publication provides complete instructions for installing this feature on this and other models. The publication is available through the IBM Support Portal, www.ibm.com/supportportal or the

IBM Publications Center www.ibm.com/shop/publications/order. Search by title or publication form number on either site.

Network Manageability

The SAN768B-2 has a single domain and is managed as a single element with Network Advisor. The SAN768B-2 responds to its own IP address and appears as a separate entity to the Telnet protocol and SNMP.

All management interfaces, such as Telnet, Web Tools, standards compliant SMI-S, and Management Server, support a “port N within blade M” naming scheme.

The SAN768B-2 supports SNMPv1 and SNMPv3. When SNMP devices send SNMP messages to a management console running SAN management software, the information is stored in a management information base (MIB). Fabric OS 7.0 and later supports the latest Fibre Alliance Fibre Channel Management (FCMGMT) and Storage Management Initiative (SMI) MIBs, which allow common information necessary for management software to provide information to a SAN administrator. Refer to the *Fabric OS MIB Reference* for additional MIB information.

Chapter 2. Installing and removing a SAN768B-2

The SAN768B-2 is only available for installation in the IBM TotalStorage 2109 SAN Switch Cabinet C36. This SAN768B-2 is to be installed and serviced only by qualified IBM service representatives. The SAN768B-2 can be ordered pre-installed in the cabinet, or the SAN768B-2 can be added to an existing C36 cabinet. The cabinet is designed to support a total of two SAN256Bs or SAN768B-2s. The SAN384B chassis can also be installed in the C36 cabinet.

Attention: The SAN768B-2 is only available for installation in the IBM TotalStorage 2109 SAN Switch Cabinet C36. The SAN768B-2 can be pre-installed in the cabinet, or it can be added to an existing IBM C36 cabinet. For installation into an existing C36 cabinet, a special bridge tool ships with the SAN768B-2 which is designed to attach to the IBM C36 cabinet. This bridge tool supports the weight of the director as it is moved into the cabinet. This tool may not attach to non-IBM cabinets. There is a risk of personal injury or machine damage during installation into any cabinet other than the approved IBM cabinets .

This chapter describes how to install the SAN768B-2 into a C36 cabinet, and how to remove the SAN768B-2 from the cabinet in the event you need to move or replace the SAN768B-2. One SAN768B-2 is installed in the cabinet at the factory. If the SAN768B-2 is already installed in the cabinet, continue on to Chapter 3, “Starting and configuring the SAN768B-2,” on page 35.

Note: Some illustrations in this chapter display different models of IBM SAN directors. Details, such as the cable management comb and blades may differ, but the procedures remain the same for installing the SAN768B-2.

Attention: Refer to “Safety and environmental notices” on page xiii for general safety instructions, and “Rack safety” on page xx before performing any installation or service procedures.



CAUTION:

The weight of this part or unit is more than 104 kg (228 lb). It takes specially trained persons with a lifting device to safely lift this part or unit. (C011)

CAUTION:

A fully populated (384 port) SAN768B-2 weighs approximately 159.2 kg (351 lb). Before you install it, verify that the additional weight of the chassis does not exceed the cabinet's weight limit or unbalance the cabinet. When you calculate the additional weight, include the weights of all components that can potentially be added, to avoid overloading in the future.

CAUTION:

For CA residents only: IBM recommends installing this product in a room size of 2190 cubic feet (62 cubic meters) or larger at 0.4 ACH ventilation rate to reduce the concentrations of any chemicals emitted by the product.

Before you install a SAN768B-2 into the cabinet, perform the following tasks:

- Read “Power specifications” on page 145 to plan for meeting power supply standards before installing the chassis.
- To ensure adequate cooling, plan to install the chassis with the port side facing the aisle where exhaust air is released (usually called the service aisle). This prevents the fans from pulling in heated exhaust air.
- Plan for managing the cables before you install the chassis. A fully populated SAN768B-2 will have a large number of cables that must be carefully routed to minimize problems with installation and replacement of components, and in order to maintain the minimum bend radius required for optical cables. Refer to “Managing cables” on page 46 for more specific information. You can manage the cables in a variety of ways, such as:
 - Routing the cables down through the cable management tray
 - Routing the cables out either side of the chassis
 - Routing the cables through the cable channels on the sides of the cabinet
 - Using patch panels
- Ensure that the airflow in the vicinity of the SAN768B-2 is a minimum of 595 cubic meters per hour (350 cubic feet per minute).
- Ensure that the air temperature that is measured at the blower inlet does not exceed 40°C (104°F) during operation.

Ordering the lift tool

Important

The lift tool is required only when you install an additional SAN768B-2 or when you install or remove the SAN768B-2 from the cabinet.

The ordering procedures for the lift tool vary depending on your location. You should direct questions about these procedures to your regional representative.

Note: The bridge tool (PN 18P5855), which is required for installation, is shipped with a new or a replacement SAN768B-2. The bridge tool, when installed, serves as a temporary ramp between the lift tool and the SAN768B-2 rails that are installed in a C36 cabinet. You do not need to return the bridge tool when you are finished with it.

World trade locations

The following ordering procedures are for world trade locations:

- Order the lift tool by using the parts order system, like any other part.
- Use the following part numbers when you order:
 - Lift tool: PN 09P2481
 - The lift tool shipment will include the 24-inch load plate: PN 11P4369
- You do not record parts usage.
- Return the lift tool and the 24-inch load plate to the parts center after you complete the installation or removal of the SAN768B-2.

United States locations

In the United States, call UPS Logistics at 800-528-6070 to order the lift tool and the 24-inch load plate.

Note: For the SSR branch and territory, the United States cannot order the lift tool or 24-inch load plate through the parts order system. UPS Logistics are used to ship and return the lift tool and 24-inch load plate.

Use the following part number when you order:

- Lift tool: PN 09P2481 (order includes 24-inch load plate: PN 11P4369)

Attention: When you order the lift tool, you will receive an 18-inch load plate and a 24-inch load plate. Do *not* use the 18-inch load plate. You *must* use the 24-inch load plate when you install the SAN768B-2 to be able to safely install this product. The 24-inch load plate includes a platform with a middle section that can slide out to extend across the gap between the lift tool and the mounting position inside the C36 cabinet.

You must provide the following information when you order the lift tool. This information is necessary to ensure that the lift tool is delivered when you need it. Failure to provide this information might delay the completion of the order request and the shipping request. It might also result in a time and date to return the tool that is different from what you need.

- Phone number and customer contact
- Account code: 98577
- Time and date of delivery
- Accurate destination address with ZIP code
- Time and date of return pickup

You must return the lift tool at the time that was scheduled with UPS Logistics. If you need to change the scheduled return time or date, contact UPS Logistics.

You are responsible for ensuring that all of the paperwork and components are packed and restored in the arbocrate (shipping container) of the lift tool. Ensure that the lift tool is functioning properly before you release the tool to UPS Logistics for return. You are accountable for the lift tool until UPS Logistics picks up the lift tool for return delivery to their parts storage facility.

Contact your branch office tools coordinator or your region specialist if you have any questions or concerns.

Installation guidelines

Follow these general installation guidelines:

1. Provide a space that is 14 rack units (14U) high, 61.29 cm (24.09 in.) deep, and 43.74 cm (17.22 in.). 1U is equal to 4.45 cm (1.75 in.).
2. Plan to install the SAN768B-2 with the non-port side facing the air-intake aisle. The SAN768B-2 can be installed facing either direction, if serviceability and cooling requirements are met.
3. Plan for cable management before installing the chassis. See “Managing cables” on page 46.

Cables can be managed in a variety of ways, such as by routing cables below the chassis, to either side of the chassis, through cable channels on the sides of the cabinet, or by using patch panels.

4. Ensure that dedicated electrical branch circuits with the following characteristics are available:

- 200 – 240 VAC, 50–60 Hz (two branch circuits) when configured with 192 16-Gbps ports (four circuits required for high availability if configured with 384 16-Gbps ports)
 - Two or four cables for 200 - 240 VAC service
 - Protected by a circuit breaker in accordance with local electrical codes
 - Supply circuit, line fusing, and wire size adequate to the electrical rating on the chassis nameplate
 - Location close to the chassis and easily accessible
 - Grounded outlets installed by a licensed electrician, compatible with the power cords
- Attention:** To maximize fault tolerance, connect each power cord to a separate power source.
5. Ensure that the following are available for configuration of the chassis:
 - Workstation with an installed terminal emulator, such as HyperTerminal
 - Serial cable (provided)
 - Three Ethernet cables (including one spare)
 - Access to an FTP server for backing up the switch configuration or collecting supportsave output data (optional)
 - SFPs (provided) and compatible cables
 6. Ensure that the air intake and exhaust vents have a minimum of 2 in. of airspace.
 7. Ensure that the air temperature on the air intake side is less than 40 degrees Celsius (104 degrees Fahrenheit) during operation.

CAUTION:

Use safe lifting practices when moving the product. (C015)

Note: A fully populated SAN768B-2 (eight FC8-64 port cards, 512 ports) weighs approximately 159.2 kg (351 lb) and requires the specified lift tool to install it.

Installing a SAN768B-2 in a cabinet

This section describes how to install the SAN768B-2 in the Model C36 cabinet. These procedures use parts that are included in the 14U rack mount kit.

Time required

Allow approximately 4 hours to complete this procedure. This includes unpacking, assembling, and repacking the lift tool. This is for the physical installation of the SAN768B-2 only. It does not include installing Ethernet cables, SFPs, attaching and routing the fiber optic cables, or completing the initial configuration.

Attention: Attention: If optional feature FC 7230, FIPS 140-2 Level 2 Tamper Proof Seals is also ordered, be sure to sequence the installation steps to allow for application of the FIPS seals on the chassis prior to installing the chassis in a rack. These locations may be difficult to access once the chassis is installed. Refer to the IBM System Storage FIPS 140-2 Security Seal Application Procedures (GA32-2220-00) publication for complete instructions.

Table 3 on page 17 provides a summary of time estimates for the different installation tasks and the tools required for each task. Times may differ, depending on experience level and your specific configuration.

Table 3. Installation tasks, time, and items required

Installation task	Time estimate	Items required
Unpacking and assembling the lift tool	15 minutes	No special tools required.
Site preparation and unpacking the SAN768B-2	30 minutes	#2 Phillips screwdriver (for cable management comb) Pallet jack (if the shipment has not been positioned near the installation site)
Installing the rack mount kit	30 minutes	Torque wrench with #2 Phillips screwdriver tip Flathead screwdriver
Mounting and securing the SAN768B-2 in the rack	30 minutes	Torque wrench with #2 Phillips screwdriver tip Lift tool and load plate
Installing power cables and powering on the SAN768B-2	20 minutes	Power cables
Establishing serial connection, logging on to the SAN768B-2, and configuring IP addresses.	20 minutes	Serial cable (provided in the accessory kit). Workstation computer with a serial port or terminal server port and a terminal emulator application (such as HyperTerminal). Ethernet IP addresses for the chassis and for both control processor blades (total of 3 IP addresses).
Installing an Ethernet cable, opening a Telnet session, and configuring the SAN768B-2 domain ID, date and time, and additional system parameters. Verifying and backing up the configuration.	20 minutes	Ethernet cable for Telnet access. Refer to the <i>Fabric OS Administrator's Guide</i> .
Installing transceivers as needed	30 minutes (longer if using high density port blades)	SFP+, mSFP, and QSFP optical transceivers as needed.
Attaching fiber optic cables, cable wraps, and cable guides	2-3 hours	Fiber optic cables and cable wraps.
Disassembling and packing the lift tool	20 minutes	No special tools required.

Note: Assembly instructions for the lift tool are in the shipping container.

Tools required

You will require the following items to install the SAN768B-2 in the cabinet:

- Torque wrench with #2 Phillips screwdriver tip
- Flathead screwdriver
- Lift tool

Parts list

The following parts list refers to items illustrated in Figure 3 on page 19

Table 4. Items supplied with the 14U rack mount kit

Item	Description	Quantity
For all types of installations		
A	Left rack mount shelf bracket (rail brackets may differ from the illustration)	1
B	Right rack mount shelf bracket (rail brackets may differ from the illustration)	1
C	10-32 x 5/8 inch (1.58 cm) panhead Phillips screw, washer	6
For cabinets that have vertical rails with round holes		
D	10-32 clip nut	6
E	1/4-20 x 1/2 in. (1.27 cm) panhead Phillips screw, with lock washer	16
For cabinets that have vertical rails with square holes		
F	10-32 retainer nut	6
G	1/4-20 x 1/2 in. (1.27 cm) panhead Phillips screw, with glue	16
H	0.375 in. (0.953 cm) alignment washer	16

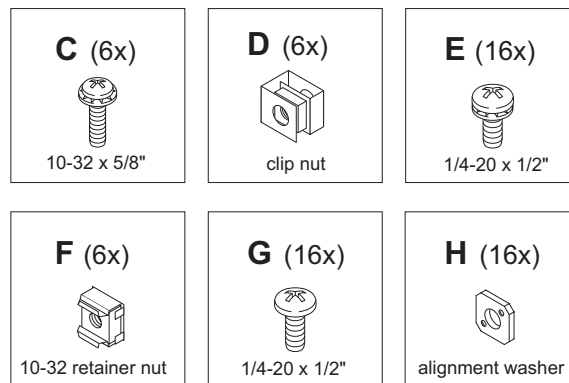
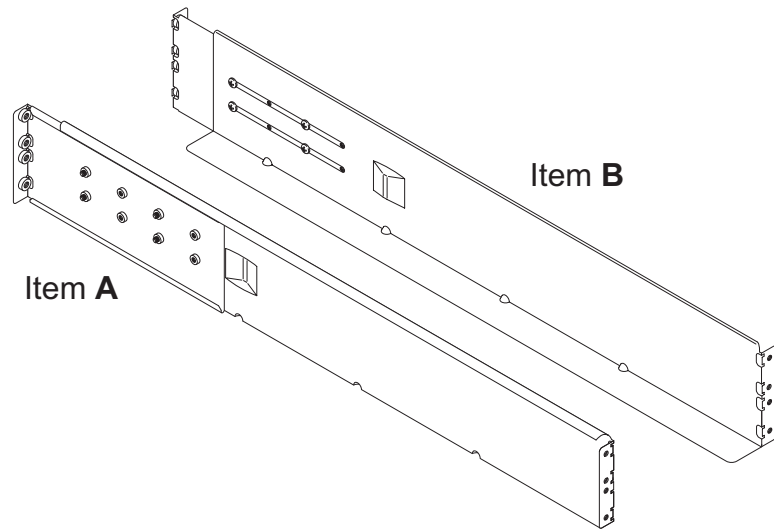

b768ig027

Figure 3. Parts in the 14U rack mount kit

Unpacking the SAN768B-2

Attention: If the product needs to be transported a long distance, or if there are uneven floors to cross, keep the product in its original packaging, and relocate the entire shipment close to the installation location, using a pallet jack to lift and move it.

To unpack the SAN768B-2, follow these steps:

1. Cut the bands that encircle the packaging.
2. Remove the lid, the 14U rack mount kit, the accessory kit, and the packing foam from the top of the chassis. Set the kits aside for later use.
3. Lift the cardboard box off the chassis and remove the plastic bag from around the chassis. Save the packing materials if you are returning an old chassis.
4. Leave the chassis on top of the plastic shipping tray if the chassis must be transported to the installation location.

Note: The standard packaging does not incorporate a wood pallet and pallet brackets. The chassis sits on top of a plastic shipping tray.

5. Use the lift tool to transport the new chassis to the installation area. Doorways must be wider than 91 cm (36 in.) to accommodate the chassis on the shipping tray.

Attaching the shelf brackets

Complete the following steps to install the shelf brackets to the cabinet rails:

1. Find the left and right rack mount shelf brackets (**A** and **B** in Figure 4) in the 14U rack mount kit. These brackets are adjustable to allow for different cabinet depths.
2. Loosen the adjusting screws on both brackets enough to allow the brackets to slide easily to adjust the length.

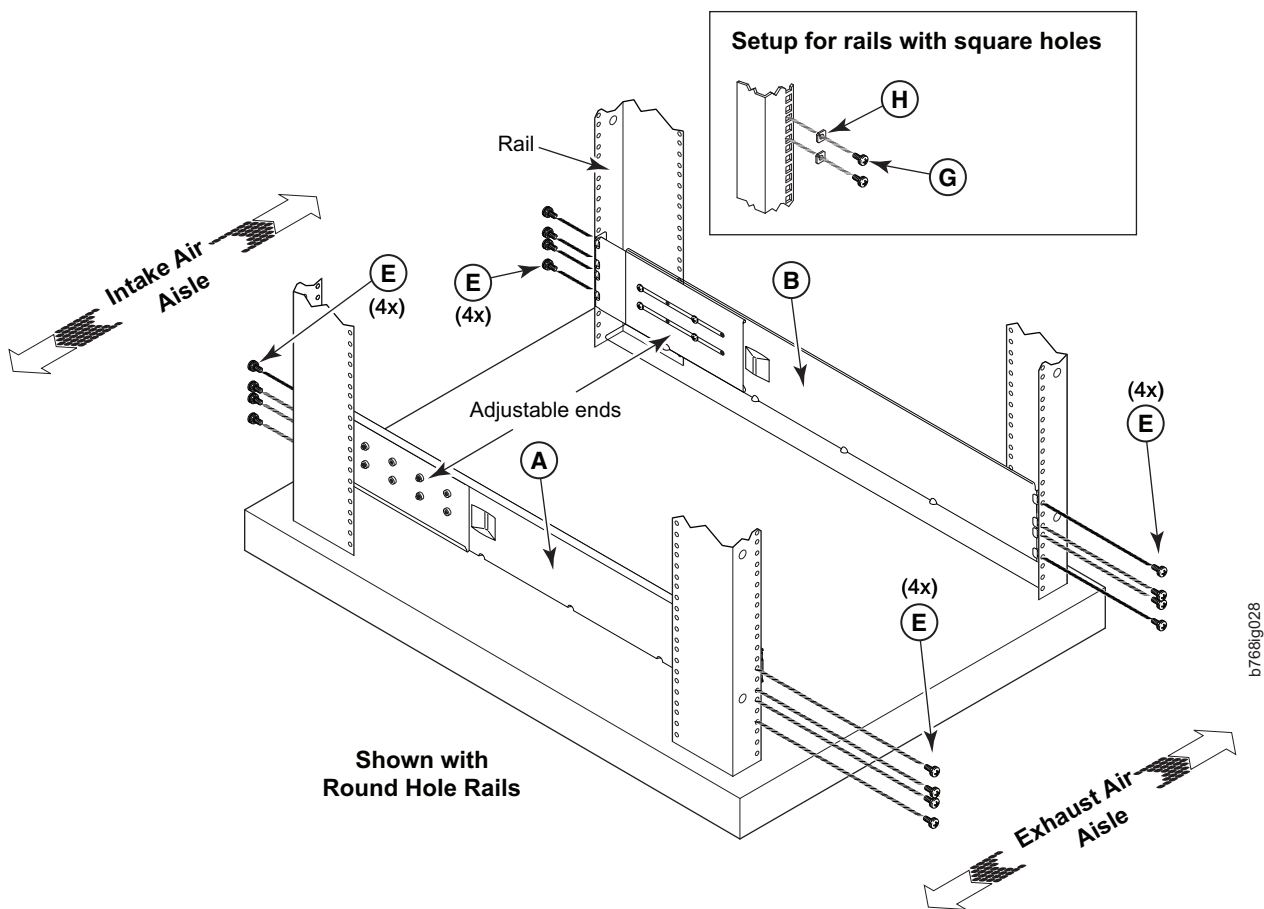

Figure 4. Left and right shelf brackets installed on the cabinet rails

3. Position the shelf brackets (**A** and **B**) with the adjustable ends at the intake aisle side of the cabinet (see Figure 4) and attach them to the cabinet rails.
 - For rails with round holes: Use eight screws with lock washers (**E**) for each bracket, four at each end. Tighten the screws to a torque of 92 cm·kg (80 in.-lb).
 - For rails with square holes: Use eight screws (**G**) eight alignment washers (**H**) for each bracket, four at each end. Tighten the screws to a torque of 92 cm·kg (80 in.-lb).

Note: Standard EIA rails have holes in sets of three; spaces between the holes are 1.58 cm, 1.58 cm, 1.27 cm (5/8 in., 5/8 in., and 1/2 in.). If cables are to be routed down through the cable management comb, allow at least 1U space below the brackets for cable management.

4. Tighten the adjusting screws on the shelf brackets to a torque of 37 cm-kg (32 in.-lb).
5. Attach the clip nuts **D** (for rails with round holes) or retainer nuts **F** (for rails with square holes) to the vertical rails on the exhaust aisle side of the cabinet (see Figure 5). These nuts are used for securing the port side of the chassis to the rack rails using 10-32 x 5/8-inch screws. Use three nuts on each rail. Place the nuts in optimum locations for securing the chassis to the rails. See Figure 7 on page 24 for approximate positions.

Note: Do not align the clip or retainer nuts with the top or bottom holes of the SAN768B-2 mounting brackets because the door will interfere with the screw heads.

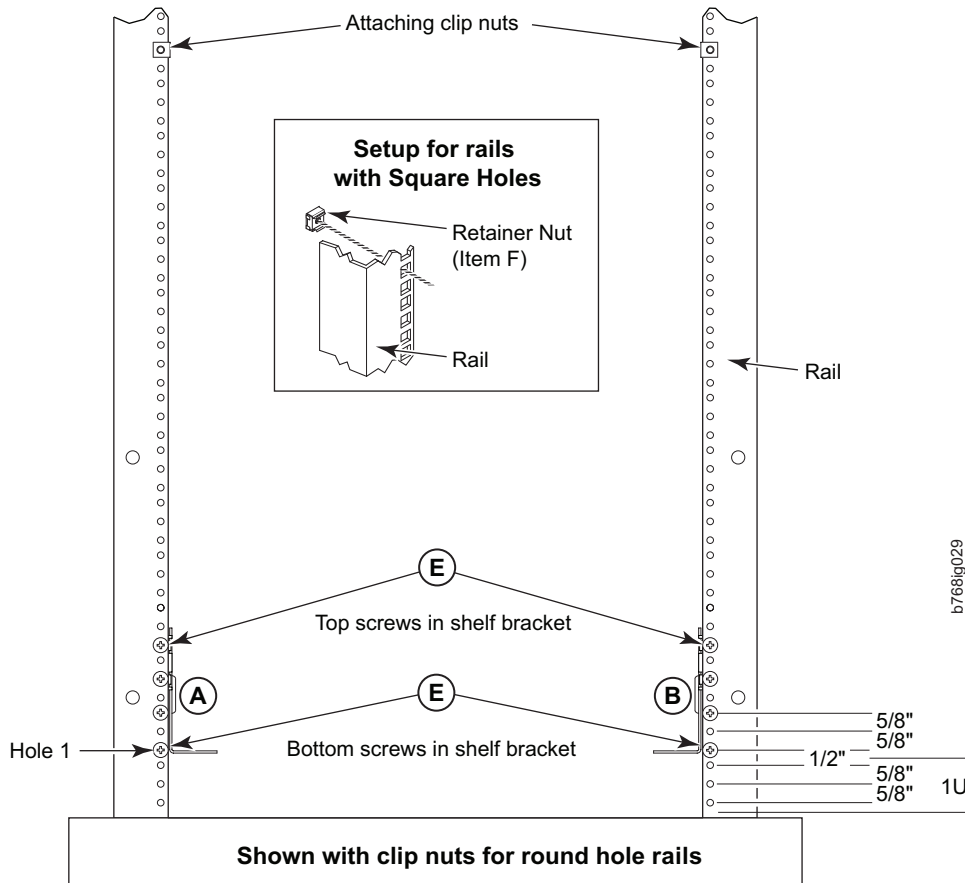

Figure 5. Installing clip or retainer nuts on the vertical cabinet rails

Removing the chassis door and cable management comb

The chassis door must be removed before the chassis can be installed into the cabinet. The door is not hinged. It is held to the chassis by mounting hardware on the door that snaps onto eight ball studs on the chassis. To remove the door, grip both sides of the door, and gently pull the door straight out until it releases from the ball studs on the chassis.

Set the door aside for later reinstallation.

Note: Reinstall the chassis door once the chassis is installed and all cabling and configuration is complete. The chassis door must be installed to ensure the SAN768B-2 meets EMI and other regulatory certifications.

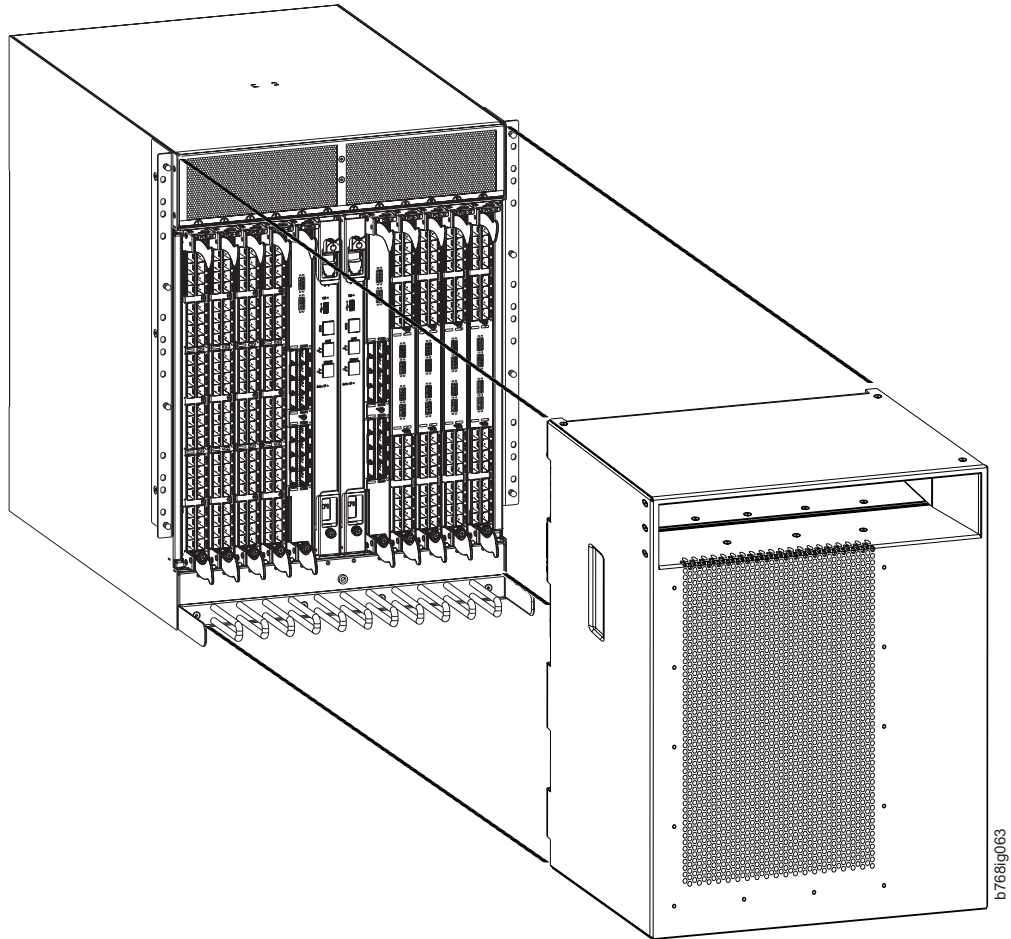

Figure 6. Chassis door removal

Remove the cable management comb (see “Removing and installing a cable management comb” on page 80), and set the parts aside for later reinstallation.

Using the lift tool, the 24-inch load plate, and the bridge tool

Step 1 on page 23 through step 9 on page 24 describe how to use the lift tool (PN 09P2481) and the 24-inch load plate (PN 11P4369) to install a SAN768B-2 in the cabinet. Step 10 on page 24 through step 23 on page 26 describe how to install the bridge tool (PN 18P5855) in the cabinet for the lower SAN768B-2 or the upper SAN768B-2. This procedure uses parts from the 14U chassis mount kit. See “Items required” on page 113 for a list of these parts.



CAUTION:

A fully populated SAN768B-2 weighs approximately 159.2 kg (351 lb) and requires a minimum of two people and a lift tool to install it. (C011)

Attention: Before you install it, verify that the additional weight of the chassis does not exceed the cabinet's weight limits or unbalance the cabinet. When you calculate the additional weight, include the cards or power supplies that partially extend out of the chassis.



CAUTION:

A pinch point exists between the load plate and the bridge tool.

Perform the following steps to install the SAN768B-2:

1. Assemble the lift tool if it is not assembled. The assembly and disassembly instructions are included with the lift tool.
2. Attach the 24-inch load plate with sliding middle section (do not use the 18-inch solid single-piece load plate)
3. Although not required, you can remove the power supplies and blower assemblies from the SAN768B-2 to reduce the weight. This can reduce the weight by up to 27 kg (60 lb).
4. Move the lift tool next to the pallet that contains the SAN768B-2.
 - a. Adjust the load platform to the same height.
 - b. Slide the SAN768B-2 from the pallet onto the load platform.
 - c. Center the switch on the load platform.
5. Attach the retention straps around the drawer.
6. If the load platform is not at its lowest position, lower the load platform to its lowest position.
7. Move the lift tool to a position near the rear of the cabinet. See Figure 7 on page 24.

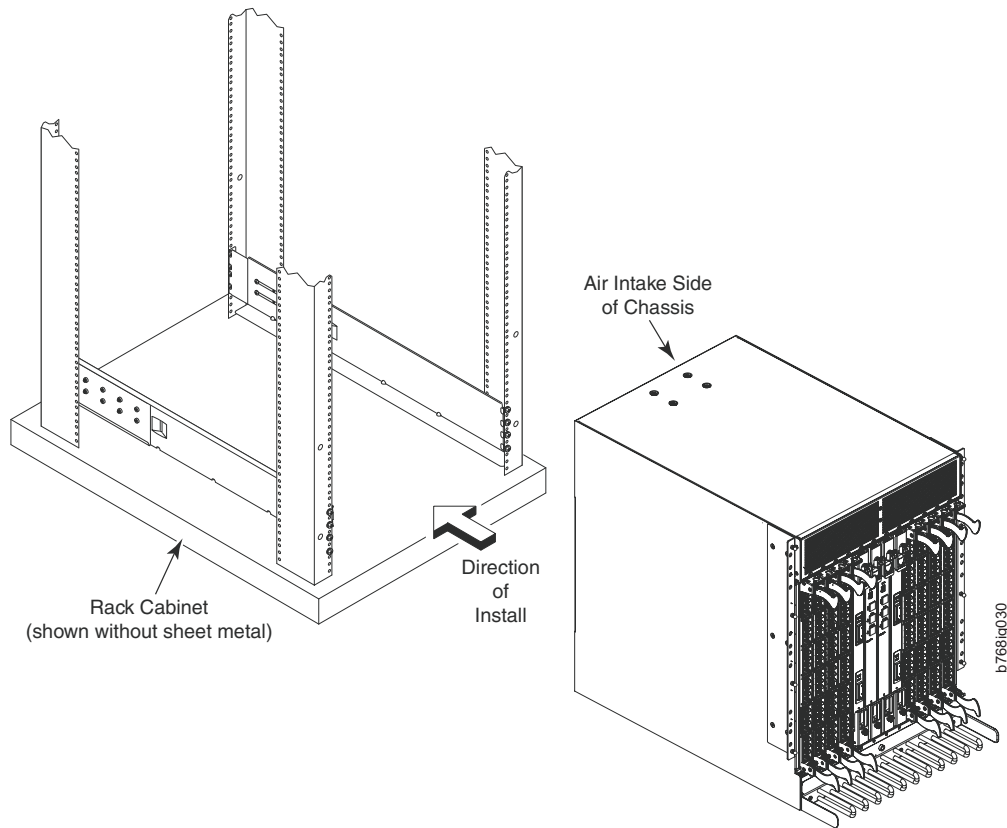

Figure 7. Chassis installation from rear (exhaust aisle side) of the cabinet

Note: If you are passing through a narrow passage or door, it might be necessary to rotate the drawer on the load platform.

8. Set the wheel brake by pressing down on the wheel brake pedal.
9. Locate the anti-tips bars. If they are not attached, attach them to the lift tool by performing step 9a through step 9d. If the anti-tip bars were previously attached, go to step 10.
 - a. Pull up on the leg lock pins and insert the anti-tip bars inside the legs.
 - b. Pull on the legs and anti-tip bars to ensure that they are locked into position.
 - c. Raise the platform to allow enough room to attach the anti-tip bracket.
 - d. Secure the anti-tip bars by using the anti-tip bracket and bolt.
10. If you are installing the lower SAN768B-2, go to step 11. If you are installing the upper SAN768B-2, go to step 12 on page 25.
11. For the lower SAN768B-2, install the bridge tool by completing the following steps:
 - a. Remove the bridge tool from the box and adjust the two supports 45°.
 - b. Hold the bridge tool between the two vertical supports near EIA unit 3, and move the two supports another 45°. Make sure that the following conditions are met:
 - The two-pin section of the support is on the back of the vertical support.
 - The one-pin section of the support is on the front of the vertical support.
 - c. Align the two-pin section of the support on the back of the vertical rail with the bottom and middle holes in EIA unit 3.

- d. Align the one-pin section of the support on the front of the vertical rail with the middle hole in EIA unit 1.

Note: Tilt the bridge tool towards the back of the cabinet approximately 45° to make it easier to align the two-pin and the one-pin sections with the vertical support.

- e. Lock the shelf into position. See Figure 8.

Note: The shelf in the picture below is shown with a different director.



Figure 8. Locking the shelf into position

12. For the upper SAN768B-2, install the bridge tool by completing the following steps:
 - a. Remove the bridge tool from the box and adjust the two supports 45°.
 - b. Hold the bridge tool between the two vertical supports near EIA unit 20, and move the two supports another 45°. Make sure that the following conditions are met:
 - The two-pin section of the support is on the back of the vertical support.
 - The one-pin section is on the front of the vertical support.
 - c. Align the two-pin section of the support on the front of the vertical rail with the bottom hole and the middle hole in EIA unit 20.
 - d. Align the one-pin section of the support on the front of the vertical rail with the middle hole in EIA unit 18.
13. Turn the winch crank counterclockwise, 1/4 turn, to set the winch brake.
14. Set the wheel brake and place the wheel chocks around the wheels.

15. Remove the retention straps.
16. Slide the SAN768B-2 into the cabinet until it rests securely on the shelf brackets.
17. Remove the wheel chocks, release the wheel brake, and move the lift tool away from the cabinet.
18. Uninstall the bridge tool and return it to its original box.
19. Reinstall the power supplies and blower assemblies if any were removed.
20. Fasten the port side of the chassis to the cabinet rails. Use three 10–32 x 5/8-in. Phillips panhead screws with washers **C** on each side to attach to the clip nuts (**D**) or retainer nuts (**F**) installed on the rails earlier. Tighten the screws to a torque of 37 cm·kg (32 in·lb). See Figure 9 for the approximate location of the screws.

Note: Do not use the top or bottom holes of the SAN768B-2 mounting brackets because the screw heads will interfere with the chassis door.

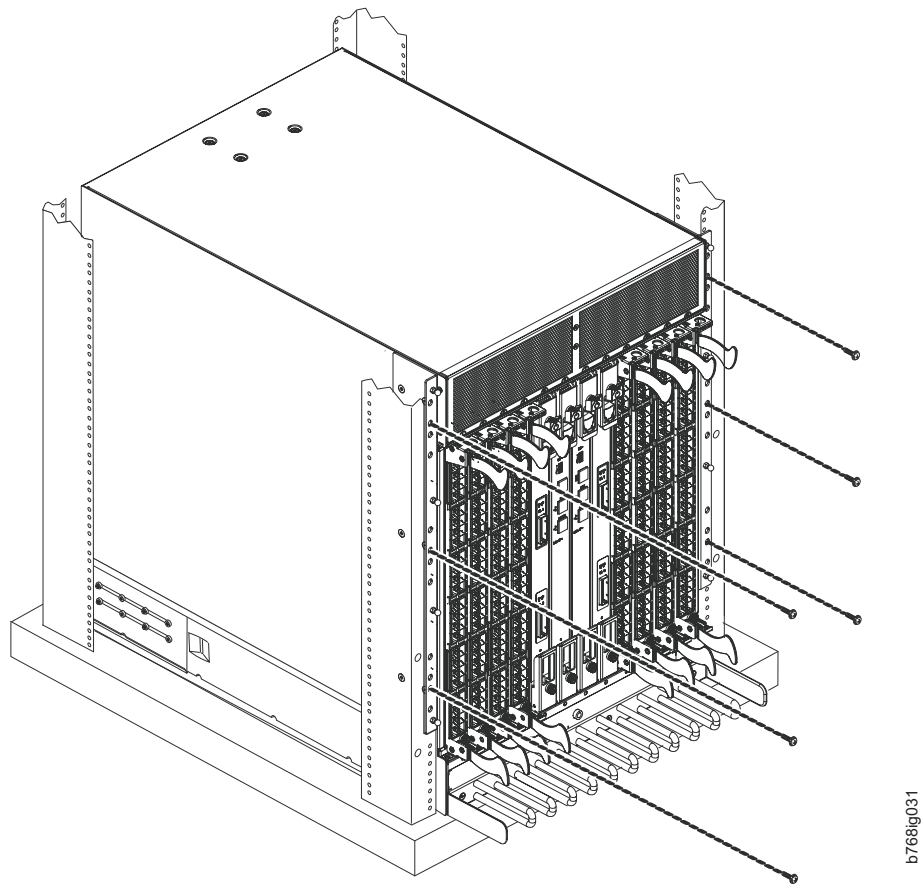

Figure 9. Attaching the port side of the chassis to the cabinet rails

21. Reinstall the cable management comb, if it was removed (see “Removing and installing a cable management comb” on page 80).
22. If ICL cables will not be used, ensure that the ICL sockets in the core switch blades have EMI plugs inserted.
23. Reinstall the chassis door. Align the door with the chassis and push it into place, as shown in Figure 10 on page 27 and Figure 11 on page 28.

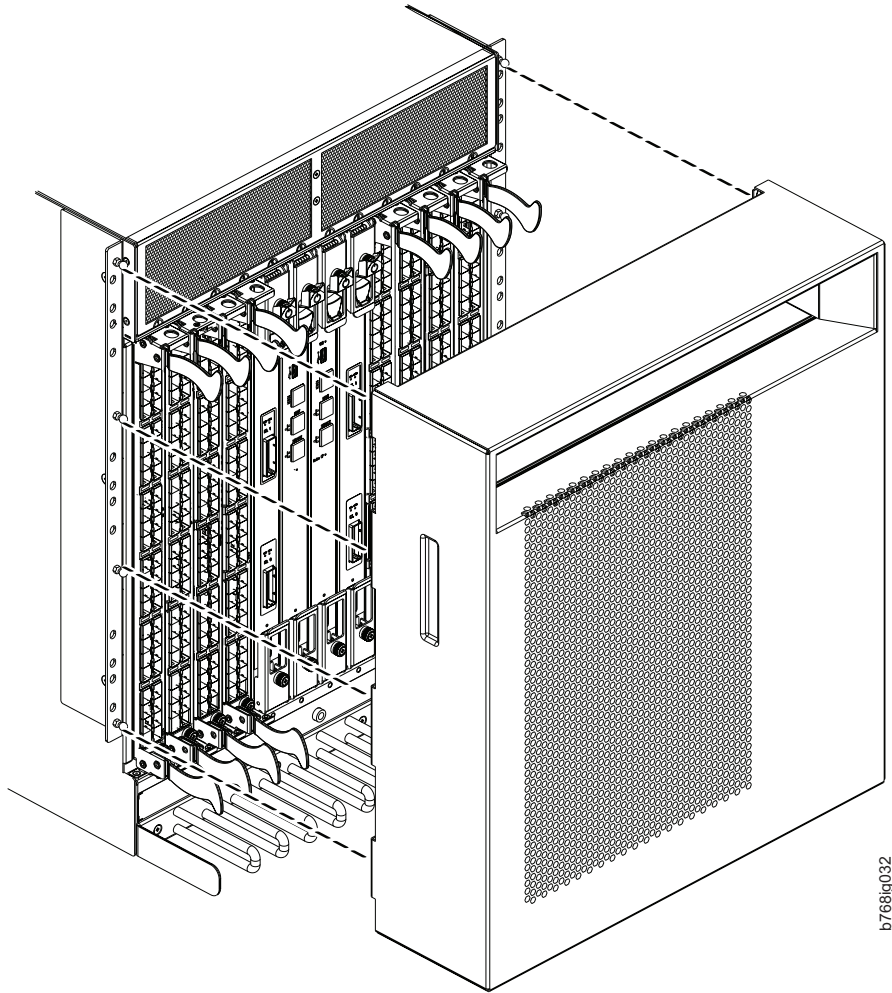

Figure 10. Aligning the chassis door with the ball studs on the chassis

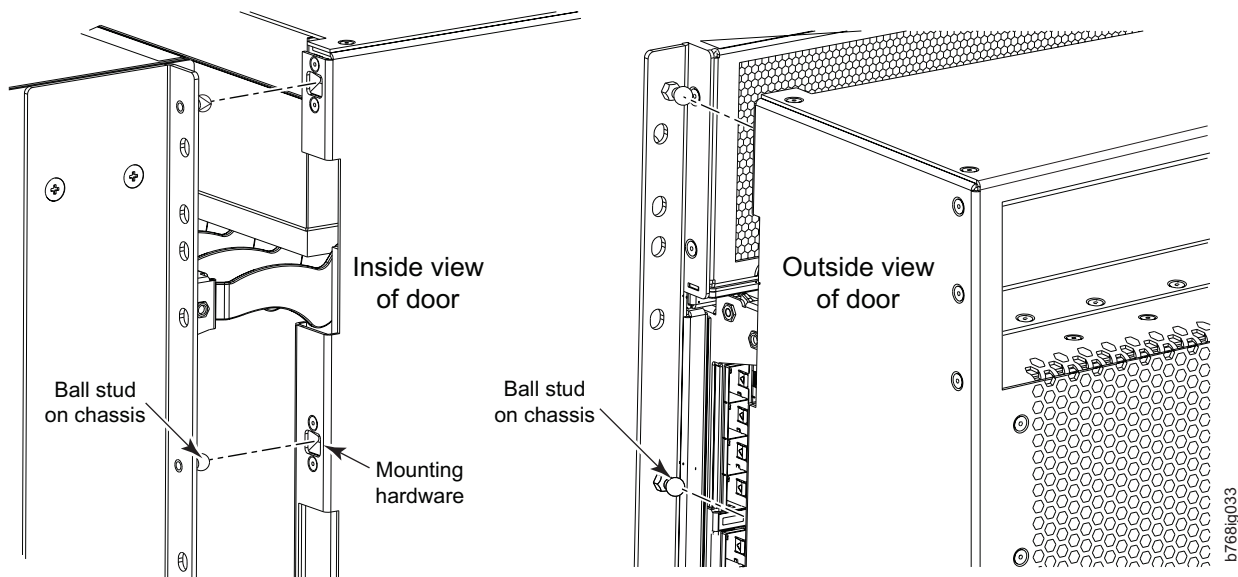

Figure 11. Details of the chassis and door, showing the ball studs on the chassis and the mounting hardware on the door

Note: For turning on the power and for the configuration instructions, see Chapter 3, “Starting and configuring the SAN768B-2,” on page 35.

Attention: Do not connect the SAN768B-2 to the network until the IP addresses are correctly set.

Port numbering

Table 5 has a list of available port blades for the SAN768B-2.

Table 5. Port and application blades available on the SAN768B-2

Blade label	IBM blade name	Feature code
FC16-32	32 port 16Gbps Switch Blade	3632
FC8-32E	32 port 8Gbps Enhanced Port Blade	3633
FC16-48	48 port 16Gbps Switch Blade	3648
FC8-48E	48 port 8Gbps Enhanced Port Blade	3649
FC8-64	64 port 8Gbps Switch Blade	3864
FX8-24	FCIP 8 Gbps Extension Blade	3890
FS8-18	16 port 8 Gbps Encryption Blade	3895

The SAN768B-2 uses the following port numbering scheme for each of the supported blades (see also Appendix E, “Blade port numbering,” on page 169 for sample configurations).

- CR16-8 core blade - Inter-chassis link connectors are numbered from 0 through 7 from bottom to top. Each connector is actually a group of four 16 Gbps ports.
- FC16-32 port blade - Ports are numbered from 0 through 15 from bottom to top on the left set of ports and 16 through 31 from bottom to top on the right set of ports.

- FC8-32E port blade - Ports are numbered from 0 through 15 from bottom to top on the left set of ports and 16 through 31 from bottom to top on the right set of ports.
- FC16-48 port blade - Ports are numbered from 0 through 23 from bottom to top on the left set of ports and 24 through 47 from bottom to top on the right set of ports.
- FC8-48E port blade - Ports are numbered from 0 through 23 from bottom to top on the left set of ports and 24 through 47 from bottom to top on the right set of ports.
- FC8-64 port blade - Ports are numbered from 0 through 31 from bottom to top on the left set of ports and 32 through 63 from bottom to top on the right set of ports. See Figure 53 on page 176 for more information. Trunking groups are permitted with up to eight ports per group. trunking groups are as follows: 0-7, 8-15, 16-23, 24-31, 32-39, 40-47, 48-55, and 56-63*. (* - Octet 56-63 E-port trunks for the SAN768B-2 are permitted on the logical or base switch only)
- FX8-24 FCIP extension blade - The port numbering scheme is fairly complex for this blade, but is displayed for reference on the blade itself in a diagram towards the lower end of the blade. (See Figure 55 on page 178 for a description and illustration of the port layout.) There are twenty-four physical ports. Twelve FC ports are located towards the lower end of the blade, with ports 0 through 5 on the left side, and ports 6 through 11 on the right side. Two 10 Gigabit Ethernet (10GbE or XGE) ports are located in the middle of the blade on the left side, and are numbered 0 and 1, from bottom to top. Ten GbE ports are located towards the top of the blade, with eight clustered at the top, and the remaining two located to the right of the two 10GbE ports. The GbE ports 0 through 3, numbered from bottom to top are located on the left side at the top of the blade. Ports 4 and 5 are located above the two 10GbE ports, and ports 6 through 9 (numbered bottom to top) are at the top on the right side, to the right of ports 0 through 3. Up to three FC trunking groups. The three groups are defined as:
 - Trunk group 0: FC ports 0, 1
 - Trunk group 1: FC ports 6, 7
 - Trunk group 2: FC ports 2, 3, 4, 5, 8, 9, 10, 11
- FS8-18 blade - The 16 physical Fibre Channel ports on this blade are numbered 0 through 15 from bottom to top. The two 10/100/1000 BaseT ports are numbered from the bottom as GE0 and GE1.

Chassis slots

Slots are numbered 1 through 12, from left to right when facing the port side of the SAN768B-2. Control processor blades (CP8) can be installed only in slots 6 and 7. Core switch blades (CR16-8) can be installed only in slots 5 and 8. Port or application blades can be installed in slots 1–4 and 9–12. Unused slots must be filled with blade filler panels to maintain adequate cooling.

See Appendix E, “Blade port numbering,” on page 169 for port numbering details of the SAN768B-2 port blades. Also refer to the IBM Redbook, *Implementing an IBM/Brocade SAN with 8 Gbps Directors and Switches*, SG24-6116, for more comprehensive information on port numbering and area port numbering, and other technical information. This publication is available through www.redbooks.ibm.com/. Search by title or publication number.

Note: This publication was written for earlier products, but many of the procedures still apply.

Cable organization

The cable management comb (**5** in Figure 1 on page 4) is attached to the chassis under the chassis door and allows for simple cable management. The comb can be installed without service disruption.

Attention: Do not use tie wraps with optical cables because they are easily overtightened and can damage the optic fibers.

Cables can be organized and managed in a variety of ways, for example, using cable channels on the sides of the cabinet or patch panels to minimize cable management. Following is a list of recommendations:

- Plan for rack space required for cable management before installing the chassis
- Leave at least 1 m (3.28 ft) of slack for each port cable. This provides room to remove and replace the switch, allows for inadvertent movement of the rack, and helps prevent the cables from being bent to less than the minimum bend radius.
- If you are using ISL Trunking, consider grouping cables by trunking groups. The cables used in trunking groups must meet specific requirements, as described in the *Fabric OS Administrator's Guide*.
- For easier maintenance, label the fiber optic cables and record the devices to which they are connected.
- Keep LEDs visible by routing port cables and other cables away from the LEDs.
- Use hook and loop type straps to secure and organize fiber optic cables.

Attention: The minimum radius to which a cable should be bent under full tensile load is 5 cm (2 in). For a cable under no tensile load, that minimum is 3 cm (1.2 in).

Attention: Do not route the cables in front of the air exhaust vent, which is located at the top of the port side of the chassis.

The FC8-64 high density port blade cannot use the standard LC cables because the pitch between optics in the new mSFP transceiver is smaller than in standard SFPs. Patch cables and panels can be used to attach standard size cabling to the blade if necessary. Figure 12 illustrates the mSFP to SFP patch cable. The mSFP transceivers are used only with the FC8-64 port blade. Narrower OM-3 LC cables are used to connect the FC8-64. These cables are offered by several major manufacturers. Contact your IBM representative for options regarding different cable and patch panel configurations to simplify cable management with higher density FC8-64 port blades.

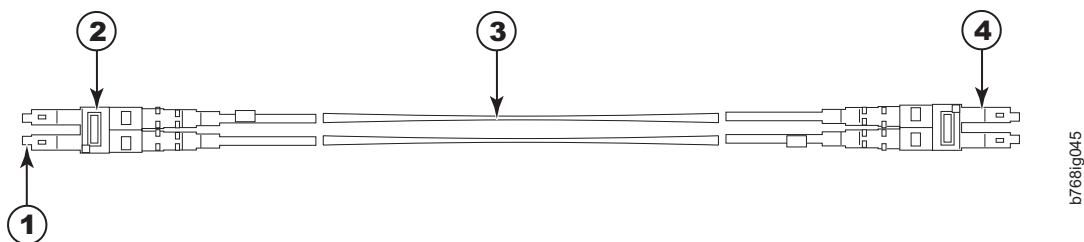

Figure 12. Cable design for the mSFP patch cables for the FC8-64 high density port blade

1 mini-SFP connector **3** 1.6 mm cable

2 Duplex clip (black)

4 SFP connector

Note that the duplex clip on the mSFP end of the cable is black for easier recognition. See Table 25 on page 148 for a listing of the qualified mSFP optical cables for the FC8-64 port blade.

If ISL Trunking is in use, group the cables by trunking group. The ports are color-coded to indicate which ports can be used in the same ISL Trunking group: eight ports marked with solid black ovals alternate with eight ports marked with oval outlines.

Table 25 on page 148 provides a listing of supported cable speeds and distances. Optional inter-chassis link cables (ICL) can also be installed between SAN768B-2 chassis. See “Removing and replacing inter-chassis link (QSFP) cables” on page 107 for instructions on installing these cables.

Removing a SAN768B-2 from the cabinet

If you need to remove a SAN768B-2 chassis from a cabinet to move it to a new location, follow the instructions below to remove the chassis, and then follow the installation instructions (“Installing a SAN768B-2 in a cabinet” on page 16) to install the chassis in the new cabinet. If you are replacing the chassis, follow the complete instructions in “Removing and replacing the chassis” on page 112.

Attention: Refer to “Safety notices and labels” on page xiii before starting any service procedure. Due to the weight of the product, this procedure requires a lift tool. See “Ordering the lift tool” on page 14 for information on ordering the lift tool.

Step 1 through step 5 describes how to use the lift tool (PN 09P2481) and the 24-inch load plate (PN 11P4369) to remove a SAN768B-2 from the cabinet. Step 6 through step 17 on page 33 describes how to remove the bridge tool (PN 18P5855) from the cabinet.

Perform the following steps to remove a SAN768B-2:

1. Assemble the lift tool if it is not assembled. The assembly and disassembly instructions are included with the lift tool.
2. Remove both power cords from the SAN768B-2.
3. Optionally, remove the power supplies and blower assemblies to reduce the weight.
4. Remove the chassis door from the chassis. See “Removing the chassis door and cable management comb” on page 21.
5. Remove the three 10-32 x 5/8 in. Phillips panhead screws with washers on each side. See Figure 9 on page 26 for the location of the screws.
6. If you are replacing the lower SAN768B-2, go to step 7. If you are replacing the upper SAN768B-2, go to step 8 on page 32.
7. Install the bridge tool by completing the following steps:
 - a. Remove the bridge tool from its box and adjust the two supports 45°.
 - b. Hold the bridge tool between the two vertical supports near EIA unit 3.
 - c. Move the two supports another 45°. Make sure that the following conditions are met:
 - The two-pin section of the support is on the back of the vertical support.

- The one-pin section of the support is on the front of the vertical support.
- d. Align the two-pin section of the support on the back of the vertical rail with the bottom and middle holes in EIA unit 3.
 - e. Align the one-pin section of the support on the front of the vertical rail with the middle hole in EIA unit 1.

Note: Tilt the bridge tool towards the back of the cabinet approximately 45° to make it easier to align the two-pin and one-pin sections with the vertical support.

- f. Lock the shelf into position.
8. For the upper SAN768B-2, install the bridge tool by completing the following steps:
 - a. Remove the bridge tool from its box and adjust the two supports 45°.
 - b. Hold the bridge tool between the two vertical supports near EIA unit 20.
 - c. Move the two supports another 45°. Make sure that the following conditions are met:
 - The two-pin section of the support is on the back of the vertical support.
 - The one-pin section of the support is on the front of the vertical support.
 - d. Align the two-pin section of the support on the back of the vertical rail with the bottom and middle holes in EIA unit 20.
 - e. Align the one-pin section of the support on the front of the vertical rail with the middle hole in EIA unit 18.
 - f. Lock the shelf into position.
 9. Locate the anti-tip bars and if they are not attached, attach them to the lift tool. If anti-tip bars were previously attached, go to step 10.
 - a. Pull up on the leg-lock pins and insert the anti-tip bars inside the legs.
 - b. Pull on the legs and anti-tip bars to ensure that they are locked into position.
 - c. Raise the platform to allow enough room to attach the anti-tip bracket.
 - d. Secure the anti-tip bars with the anti-tip bracket and bolt.
 10. Move the lift tool to a position near the rear of the cabinet.
 11. Turn the winch crank clockwise to raise the switch. Move the lift tool into position in front of the cabinet while you align the 24-inch load plate with the line on the bridge tool.
 12. Turn the winch crank counterclockwise 1/4 turn to set the winch brake.
 13. Set the wheel brake. Place the wheel chocks around the wheels.



CAUTION:

A fully populated SAN768B-2 weighs approximately 159.2 kg (351 lb) and requires a minimum of two people and a lift tool to install it. (C011)



CAUTION:

A pinch point exists between the load plate and the bridge tool.

14. Slide the SAN768B-2 from the cabinet onto the 24-inch load plate. Center the SAN768B-2 on the platform.

15. Install the retention straps.
16. Remove the wheel chocks, release the wheel brake, and move the lift tool away from the cabinet.
17. Lower the load platform to its lowest position.
18. Remove the bridge tool.

Chapter 3. Starting and configuring the SAN768B-2

Attention: Refer to the latest Fabric OS Release Notes or Interoperability Matrix for information regarding Fabric OS compatibility. This is particularly important for fabrics with 1-Gbps switches using earlier Fabric OS versions. To access the appropriate matrix:

- Go to the IBM SAN web page www.ibm.com/systems/storage/san
- Select the **IBM System Storage SAN768B-2 and SAN384B-2** product link
- On the displayed product page, click the **Interoperability Matrix** link in the **Learn more** section.

The SAN768B-2 must be configured before it is connected to the fabric, and all of the configuration commands must be entered through the active CP blade. The SAN768B-2 configuration includes the following parameters:

- IP address and subnet mask for the chassis
- IP addresses, host names, subnet masks, and gateway addresses for both CP blades
- Switch name
- Domain ID for the SAN768B-2 (optional)
- WWN for the SAN768B-2

Note: The SAN768B-2 WWN is initially set by the factory to match the license ID (which is based on the chassis serial number). The WWN can be changed, but the license ID cannot be modified.

The configuration information is mirrored to the standby CP blade, which allows the most current configuration to remain available even if the active CP blade fails. The configuration information for the SAN768B-2 is stored in the WWN cards and the flash memory of the CP blades. The configuration can be backed up to a workstation (uploaded) and then downloaded to the active CP blade if necessary.

Note: If the FS8-18 encryption blade is installed, refer to the *Fabric OS Encryption Administrator's Guide Supporting Tivoli Key Lifecycle Manager (TKLM) Environments* for the procedures to configure the encryption functions.

Figure 13 on page 36 provides an overview of the sequence of tasks to configure the SAN768B-2.

Configuration Tasks

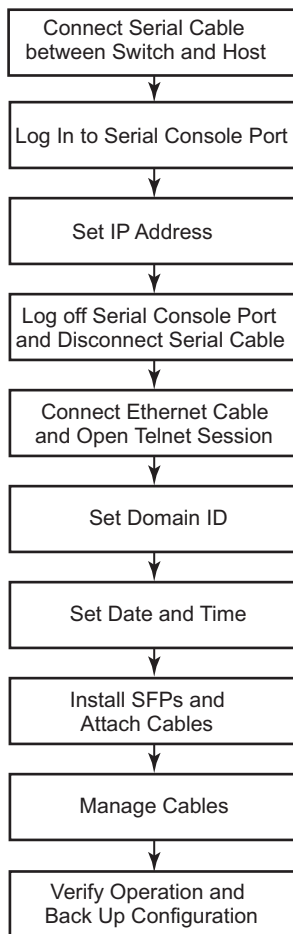

384b004

Figure 13. Flow of basic configuration tasks

The initial physical hardware installation continues with the following steps:

- “Providing power to the SAN768B-2” on page 37
- “Establishing a serial connection and logging on to the SAN768B-2” on page 37
- “Configuring the IP addresses” on page 38

The following additional steps are customer responsibilities, generally completed during the initial configuration:

1. Establish an Ethernet connection. See “Establishing an Ethernet connection” on page 40.
2. Specify a switch name. See “Customize a switch name” on page 40.
3. Specify a domain ID for the SAN768B-2. See “Setting the Domain ID” on page 41.
4. Verify the PID mode and connect the SAN768B-2 to the fabric. See “Verifying the persistent PID feature” on page 43.
5. Enable software licenses. See “Determining installed software licenses” on page 43.
6. Configure the optional FS8-18 encryption blade. See “Configuring for encryption (optional)” on page 48

7. Back up the configuration. See “Verifying correct operation and backing up the configuration” on page 49.

Providing power to the SAN768B-2

DANGER

Use the supplied power cords. Ensure the facility power receptacle is the correct type, supplies the required voltage, and is properly grounded. (D004)

To provide power to the SAN768B-2:

1. Connect the AC power cords to the power supply assemblies. Two or four power cords are required depending on electrical service.
Attention: A chassis fully loaded with 16 Gbps port blades (384 ports total) should be supplied with four power supplies connected to 200-240 VAC lines.
2. Connect the power cords to power sources with voltage of 200 to 240 VAC, 47 to 63 Hz (two or four power cords).
3. Turn the AC power switches on the power supplies to ON (I). The AC power switches turn light green when turned on and power is supplied.
4. The SAN768B-2 performs a power-on self-test (POST) each time it is powered on. POST takes approximately 10 minutes and is complete when indicator light activity indicates the operational state. For information about LED patterns, see Chapter 4, “Monitoring system components,” on page 53.

You can bypass POST by using the **fastBoot** command. You can also disable POST for successive reboots on the SAN768B-2 using the **diagDisablePost** command.

Attention: To prevent a potential IP address conflict, do not connect the SAN768B-2 to the network until the IP addresses are configured.

Note: To power off the SAN768B-2, see “Powering off the SAN768B-2” on page 51.

Establishing a serial connection and logging on to the SAN768B-2

To establish a serial connection and log on to the SAN768B-2:

1. Verify that the SAN768B-2 is powered on and that POST is complete by verifying that all power LED indicators on the port, control processor, and core switch blades display a steady green light.
2. Remove the shipping cap from the CONSOLE port on the active CP. The active CP blade is indicated by an illuminated (blue) LED. Use the serial cable provided with the SAN768B-2 to connect the CONSOLE port on the active CP to a computer workstation.

Attention: The CONSOLE port is intended primarily for the initial setting of the IP address and for service purposes.

3. Access the SAN768B-2 using a terminal emulator application (such as HyperTerminal in a Windows environment or TERM in a UNIX environment).
4. Disable any serial communication programs running on the workstation (such as synchronization programs).
5. Open the terminal emulator application and configure as follows:
 - For most Microsoft Windows systems, use the following configuration parameters.

Bits per second: 9600
Data bits: 8
Parity: None
Stop bits: 1
Flow control: None

- For most UNIX systems, type the string at the prompt:

```
term /dev/ttyb -9600
```

If ttyb is already taken, use ttya instead and enter the following string at the prompt:

```
term /dev/ttya -9600
```

When the terminal emulator application stops reporting information, press Enter. You will receive the following login prompt:

```
CP0 Console Login:
```

Logging in to the serial console port

To log in to the SAN768B-2 through the serial connection, follow these steps.

1. Log in to the SAN768B-2 as **admin**. The default password is "**password**." At the initial login, you are prompted to change the default passwords. Record the new passwords and keep this information in a secure location. The example below shows the login without changing the password.

```
Fabric OS (swDir)
```

```
swDir login: admin
```

```
Password:
```

```
Please change your passwords now.
```

```
Use Control-C to exit or press 'Enter' key to proceed.
```

```
Password was not changed. Will prompt again at next login  
until password is changed.
```

```
swDir:admin>
```

2. (Optional) Modify passwords. To skip modifying the password, press **Ctrl+C**. Passwords can be 8 to 40 characters long. They must begin with an alphabetic character. They can include numeric characters, the dot (.), and the underscore (_). Passwords are case-sensitive, and they are not displayed when you enter them on the command line. For more information on passwords, refer to the *Fabric OS Administrator's Guide*.

Configuring the IP addresses

The SAN768B-2 requires three IP addresses, which are set using the **ipAddrSet** command. IP addresses are required for both CP blades (CP0 and CP1) and for the chassis management IP (shown as SWITCH under the **ipAddrShow** command). These IP addresses are set using the **ipAddrSet** command through the serial or Ethernet connection to the active CP blade.

Note: The default IP addresses and host names for the SAN768B-2 are as follows:

- 10.77.77.75 for CP0 (the CP blade in slot 6 at the time of configuration)
- 10.77.77.74 for CP1 (the CP blade in slot 7 at the time of configuration)

Attention: Resetting an IP address while the SAN768B-2 has active IP traffic such as Fabric Manager, Fabric Watch, SNMP, or other applications can cause traffic to be interrupted or stopped.

Complete the following steps to set the IP addresses for the SAN768B-2.

1. Log in to the active CP as **admin** using the serial connection.
2. Set up the SAN768B-2 IP address by entering the **ipaddrset -chassis** command at the prompt.

```
swDir:admin> ipaddrset -chassis
```

Enter the information at the prompts. Specify the **-chassis** IP address. The **-sw 0** IP address is not valid on this chassis.

Note: The addresses 10.0.0.0 through 10.0.0.255 are reserved and used internally by the SAN768B-2. External IPs must not use these addresses.

3. Set up the CP0 blade IP address by entering the **ipaddrset -cp 0** command at the prompt.

```
swDir:admin> ipAddrSet -cp 0
```

Enter the requested information at the prompts.

4. Set up the CP1 blade IP address by entering the **ipaddrset -cp 1** command at the prompt.

```
swDir:admin> ipAddrSet -cp 1
```

Enter the requested information at the prompts.

The following is a sample IP configuration for the SAN768B-2 (chassis) and the two CP blades (cp0 and cp1).

```
swDir:admin>ipaddrset -chassis
Ethernet IP Address [0.0.0.0]: 123.123.123.120
Ethernet Subnetmask [0.0.0.0]: 123.123.123.123
Fibre Channel IP Address [0.0.0.0]:
Fibre Channel Subnetmask [0.0.0.0]:
Issuing gratuitous ARP...Done.
Committing configuration...Done.
```

```
swDir:admin> ipaddrset -cp 0
Host Name [cp0]:
Ethernet IP Address [10.77.77.75]: 123.123.123.121
Ethernet Subnetmask [0.0.0.0]: 123.123.123.123
Gateway IP Address [0.0.0.0]: 123.123.123.124
IP address is being changed...Done.
Committing configuration...Done.
```

```
swDir:admin> ipaddrset -cp 1
Host Name [cp1]:
Ethernet IP Address [10.77.77.74]: 123.123.123.122
Ethernet Subnetmask [0.0.0.0]: 123.123.123.123
Gateway IP Address [0.0.0.0]: 123.123.123.124
IP address of remote CP is being changed...Done.
Committing configuration...Done.
swDir:admin> reboot
```

Logging off the serial console port and disconnecting the serial cable

You can use the serial port to monitor error messages through the serial connection. If the serial port is no longer required, use the **logout** command to log out of the serial console, remove the serial cable, and replace the plug in the serial port.

Establishing an Ethernet connection

Note: Connecting the CP blades to a private network/VLAN is recommended.

After using a serial connection to configure the IP addresses for the SAN768B-2, you can connect the active CP blade to the local area network (LAN).

By establishing an Ethernet connection, you can complete the SAN768B-2 configuration using a serial session, Telnet, or through a management application such as Network Advisor.

To establish an Ethernet connection to the SAN768B-2, follow these steps:

1. Remove the shipping plug from the Ethernet port on the active CP blade.
2. Insert one end of an Ethernet cable into the Ethernet port.
3. Connect the other end to an Ethernet 10/100/1000 Base-T LAN.

The SAN768B-2 can now be accessed by remote connection using the command line via Telnet or any of the management tools, such as Web Tools or Network Advisor.

4. To complete any additional SAN768B-2 configuration procedures through a Telnet session, log in to the SAN768B-2 by Telnet, using the **admin** login. The default password is **password**.

Customize a switch name

The switch name of the SAN768B-2 can be up to 30 characters long; can include letters, numbers, and underscore characters; and must begin with a letter.

Note: Changing the name causes a domain address format RSCN to be issued.

To customize the name, follow these steps:

1. Enter the **switchName** command with the new name in quotes.

```
swDir:admin> switchName "ModularSwitch5"  
Committing configuration...  
Done.  
ModularSwitch5:admin
```

2. Record the new name for future reference.

Customizing a chassis name

The chassis name of the SAN768B-2 can be up to 15 characters long; can include letters, numbers, hyphens, and underscore characters; and must begin with a letter.

1. Enter **chassisName** followed by the new name in double quotation marks.

```
switch:admin> chassisname "SAN768B-2_chassis_1"  
Committing configuration...  
Done.
```

2. To display the new chassis name, enter the **chassisName** command.

```
switch:admin> chassisname SAN768B-2_chassis_1
```

3. Record the new name for reference.

Setting the Domain ID

Each switch in the fabric must have a unique Domain ID. The Domain ID can be set using the **configure** command or can be automatically set. The default Domain ID for the SAN768B-2 is "1".

To set the Domain ID, follow these steps:

1. Enter the **switchDisable** command to disable the SAN768B-2.
2. Enter the **configure** command.
3. Enter **y** at the "*Fabric parameters*" prompt:

```
Fabric parameters (yes, y, no, n): [no] y
```

4. Enter a unique Domain ID:

```
Domain: (1..239) [1] 3
```

5. Complete the remaining prompts or press **Ctrl+D** to accept the settings and to exit.
6. Enter the **switchEnable** command to re-enable the SAN768B-2.

Setting the date and time

The date and time settings are used for logging events. Switch operation does not depend on the date and time; a switch with an incorrect date and time value still functions properly. However, because the date and time are used for logging, error detection, and troubleshooting, they should be set correctly.

Setting the date

To set the date, follow these steps.

1. If necessary, log on to the SAN768B-2 by Telnet, using the **admin** account. The default password is **password**.

2. Enter the **date** command, using the following syntax: **date "mmddHHMMyy"**

Where:

- mm is the month; valid values are 01 through 12.
- dd is the date; valid values are 01 through 31.
- HH is the hour; valid values are 00 through 23
- MM is minutes; valid values are 00 through 59.
- yy is the year; valid values are 00 through 99 (values greater than 69 are interpreted as 1970 through 1999, and values less than 70 are interpreted as 2000-2069).

```
switch:admin> date
Fri Sep 24 17:01:48 UTC 2010
switch:admin> date "0927123010"
Mon Sep 27 12:30:00 UTC 2010
switch:admin>
```

Setting the time zone

You must perform the procedure on all chassis for which the time zone must be set. However, you only need to set the time zone once on each switch, because the value is written to nonvolatile memory. Use one of the two following procedures to set the time zone.

The following procedure describes how to set the current time zone using **timezone_fmt** mode to Central Standard time.

1. Log on to the chassis using the **admin** account. The default password is **password**

2. Enter the **tsTimeZone** command as follows:

```
switch:admin> tstimezone [--interactive]/ [, timezone_fmt]
```

Use **timezone_fmt** to set the time zone by Country/City or by time zone ID, such as PST. The following example shows how to change the time zone to US/Central.

```
switch:admin> tstimezone_fmt  
Time Zone : US/Pacific  
switch:admin> tstimezone US/Central  
switch:admin> tstimezone  
Time Zone : US/Central
```

The following procedure describes how to set the current time zone using interactive mode to Pacific Standard Time.

1. Enter the **tsTimeZone** command as follows:

```
switch:admin> tstimezone --interactive
```

2. You are prompted to select a general location.

Please identify a location so that time zone rules can be set correctly.

3. Enter the appropriate number or **Ctrl+D** to quit.

4. At the prompt, select a **country location**.

5. At the prompt, enter the appropriate number to specify the time zone region or **Ctrl+D** to quit.

Synchronizing local time

To synchronize the local time of the principal or primary switch with that of an external NTP server, follow these steps.

1. If necessary, log on to the switch by Telnet, using the **admin** account.

2. Enter the **tsClockServer** command:

```
switch:admin> tsclockserver "<ntp1;ntp2>"
```

where **ntp1** is the IP address or DNS name of the first NTP server, which the switch must be able to access. The variable **ntp2** is the second NTP server and is optional. The operand "**<ntp1;ntp2>**" is optional; by default, this value is **LOCL**, which uses the local clock of the principal or primary switch as the clock server.

The **tsClockServer** command accepts multiple server addresses in either IPv4, IPv6, or DNS name formats. When multiple NTP server addresses are passed, **tsClockServer** sets the first obtainable address as the active NTP server. The others will be stored as backup servers that can take over if the active NTP server fails. The principal or primary FCS switch synchronizes its time with the NTP server every 64 seconds.

```
switch:admin> tsclockserver  
LOCL  
switch:admin> tsclockserver "132.163.135.131"  
switch:admin> tsclockserver  
132.163.135.131  
switch:admin>
```

The following example shows how to set up more than one NTP server using a DNS name:

```
switch:admin> tsclockserver "10.32.170.1;10.32.170.2;ntp.localdomain.net"
Updating Clock Server configuration...done.
Updated with the NTP servers
```

Changes to the clock server value on the principal or primary FCS switch are propagated to all switches in the fabric

Verifying the persistent PID feature

Before connecting the SAN384B-2 to the fabric, verify that the WWN Based persistent port identifier (PID) feature on the SAN384B-2 matches the other switches in the fabric. This parameter must be identical for all switches in the fabric and is set using the configure command as shown below:

```
switch:admin>configure
Configure...
Fabric parameters (yes, y, no, n): [no] y
Domain: (1..239) [1]
Enable a 256 Area Limit
  (0 = No,
   1 = Zero Based Area Assignment,
   2 = Port Based Area Assignment): (0..2) [0] 1
WWN Based persistent PID (yes, y, no, n): [no] yes
<command output truncated>
```

You can check the PID setting using the **configshow** command as in the following example. You can use the **| grep -i pid** qualifier to pinpoint the PID information.

```
switch:admin> configshow | grep -i pid
fabric.ops.mode.pidFormat:1
fabric.wwnPidMode:1
```

The 1 indicates that the WWN Based persistent PID feature is enabled. The default value is 0 for disabled.

Determining installed software licenses

Certain licenses may be factory installed on the SAN768B-2. To determine which licenses are currently enabled, use the **licenseShow** command.

```
swDir:admin> licenseshow
AAbbccDDeeFFeeGG:
  Web license
  Zoning license
  Extended Fabric license
  Fabric Watch license
  Performance Monitor license
  Trunking license
  Security license
```

In the example above, the license key is *AAbbccDDeeFFeeGG*. Keep a copy of the license key for reference.

The 64-bit chassis ID is required to obtain and activate licenses for the SAN768-2. The chassis ID is available through the **licenseIdShow** command.

The **licenseShow** and **licenseIdShow** commands must be entered on the active CP blade.

Refer to the *Fabric OS Administrator's Guide* for more information.

Installing transceivers and attaching cables

The following two sets of steps cover the installation of transceivers and cables for most SFPs and for QSFPs.

Attention: Use only transceivers that are supported for this product. Only transceivers purchased from IBM are supported. The use of transceivers that are not supported may cause data loss or cause the product to malfunction. For a listing of transceivers compatible with this product:

- Go to the IBM Support Portal www.ibm.com/supportportal.
- In the **Search** field, enter **b-type supported transceiver**.
- Alternatively, use this direct link: <http://www-01.ibm.com/support/docview.wss?uid=ssg1S1004421>.

Follow the first set of steps to install SFP+s and mSFPs (FC8-64 port blade only) and cables in the SAN768B-2 (for more details, see “Removing and installing transceivers” on page 104). Follow the second set of steps to install the QSFP transceivers and cables in the core blades for inter-chassis link connections (for more details, see “Removing and replacing inter-chassis link (QSFP) cables” on page 107).

Attention: mSFP transceivers are compatible only with the FC8-64 port blade. While they will fit in other blades, this configuration is unsupported and will generate an error.

Attention: With increasing speeds of optical connections, the cleanliness of the connections assumes greater importance in ensuring maximum performance and error free transmission. Due to the tighter tolerances associated with state of the art optics, levels of contamination that were acceptable at lower speeds may not be at higher speeds. While IEC Standard 61300-3-35 specifies a set of guidelines for trouble free performance, most issues can be avoided by adhering to the following best practices:

- When cables or connectors are not in use for extended periods of time, use the dust covers provided.
- Ensure that the cable length and type that is used are suitable for the speed and application.
- Inspect and clean optical connections and fiber cables before you connect or reconnect components.
- Ensure that cables are properly seated within the connector.

Kits are commercially available for cleaning and inspecting these connections. IBM also offers services that will ensure optimal condition of the network.

The ports are color-coded to indicate which can be used in the same port group for trunking (trunking port groups can be up to eight ports). The ports and cables used in trunking groups must meet specific requirements. Refer to the *Fabric OS Administrator's Guide* for more information.

Installing SFP+ and mSFP transceivers and cables

Follow these steps to add the optical transceivers and cables to the Fibre Channel ports.

1. Ensure that both cable and transceiver are clean prior to installation.

2. Position one of the optical transceivers so that the key is oriented correctly to the port. Insert the transceiver into the port until it is firmly seated and the latching mechanism clicks.

Transceivers are keyed so that they can only be inserted with the correct orientation. If a transceiver does not slide in easily, ensure that it is correctly oriented.

3. Position a cable so that the key (the ridge on one side of the cable connector) is aligned with the slot in the transceiver; then, insert the cable into the transceiver until the latching mechanism clicks.

Cables are keyed so that they can only be inserted with the correct orientation. If a cable does not slide in easily, ensure that it is correctly oriented.

4. Repeat steps 1 and 2 for the remaining ports.
5. Organize the cables as required. For recommendations regarding cable management, refer to “Managing cables” on page 46.
6. Verify the chassis and port status using the **switchShow** command.
7. Verify fabric connectivity using the **fabricShow** command.

Installing QSFP transceivers and ICL cables

Follow these steps to install the QSFPs and cables in the 16 Gbps core blades. These transceivers and cables are used to form the inter-chassis links (ICL) with neighboring SAN768B-2 and SAN384B-2 backbones. The transceivers should be installed in the blades before connecting the cables. Because each QSFP contains four 16 Gbps ports, be aware that any problems with one port could affect all four ports in the quad if the QSFP has to be replaced.

1. Position one of the QSFP transceivers so that the key is oriented correctly to the port. Insert the transceiver into the port until it is firmly seated. Transceivers are keyed so that they can only be inserted with the correct orientation. If a transceiver does not slide in easily, ensure that it is correctly oriented. When the transceiver is correctly seated, the status LED will flash amber several times and then turn solid amber.
2. Remove the protective cap from the special QSFP cable and insert it into the transceiver until it is firmly seated. The cables are also keyed to fit into the transceivers correctly. When the cable is correctly seated, the status LED will change from amber to green.
3. Repeat steps 1 and 2 for the remaining ICL.
4. Organize the cables (see “Managing cables” on page 46).
5. Verify the chassis and connector and port status using the **switchShow -qsfp** command. A sample of the command output is shown below. The example is from a SAN384B-2 with a core blade installed in slot 3. Some details for the SAN768B-2 will be different (such as the slot numbers), but the reported information for the QSFPs will be similar. Note that the State reported for an unconnected QSFP (shown QSFP 0 and Ports 0-3 below) is No_SigDet. This is different from the State of No_Synch that is reported for regular SFPs that are unconnected. QSFP 7 (ports 3/28-3/31, Index 748-751) in the following example shows the results for a connected QSFP.

```
switch:FID128:admin> switchshow -qsfp
switchName: switch name
switchType: 121.3
switchState: Online
switchMode: Native
switchRole: Subordinate
switchDomain: 75
switchId: fffc4b
```



```

switchWwn: 10:00:00:05:1e:4f:eb:00
zoning: ON (zoning name)
switchBeacon: OFF
FC Router: OFF
Allow XISL Use: OFF
LS Attributes: [FID: 128, Base Switch: No, Default Switch: Yes, Address Mode
0]

```

Index	Slot	Port	QSFP	Address	Media	Speed	State	Proto
256	3	0	0	-----	id	16G	No_SigDet	FC
257	3	1	0	-----	id	16G	No_SigDet	FC
258	3	2	0	-----	id	16G	No_SigDet	FC
259	3	3	0	-----	id	16G	No_SigDet	FC
260	3	4	1	-----	--	16G	No_Module	FC
261	3	5	1	-----	--	16G	No_Module	FC
262	3	6	1	-----	--	16G	No_Module	FC
263	3	7	1	-----	--	16G	No_Module	FC
264	3	8	2	-----	--	16G	No_Module	FC
265	3	9	2	-----	--	16G	No_Module	FC
266	3	10	2	-----	--	16G	No_Module	FC
267	3	11	2	-----	--	16G	No_Module	FC
268	3	12	3	-----	--	16G	No_Module	FC
269	3	13	3	-----	--	16G	No_Module	FC
270	3	14	3	-----	--	16G	No_Module	FC
271	3	15	3	-----	--	16G	No_Module	FC
736	3	16	4	-----	--	16G	No_Module	FC
737	3	17	4	-----	--	16G	No_Module	FC
738	3	18	4	-----	--	16G	No_Module	FC
739	3	19	4	-----	--	16G	No_Module	FC
740	3	20	5	-----	--	16G	No_Module	FC
741	3	21	5	-----	--	16G	No_Module	FC
742	3	22	5	-----	--	16G	No_Module	FC
743	3	23	5	-----	--	16G	No_Module	FC
744	3	24	6	-----	--	16G	No_Module	FC
745	3	25	6	-----	--	16G	No_Module	FC
746	3	26	6	-----	--	16G	No_Module	FC
747	3	27	6	-----	--	16G	No_Module	FC
748	3	28	7	-----	id	16G	Online	FC E-Port
10:00:00:05:1e:39:e4:5a "trunkmaster name" (Trunk master)								
749	3	29	7	-----	id	16G	Online	FC E-Port
10:00:00:05:1e:39:e4:5a "trunkmaster name" (Trunk master)								
750	3	30	7	-----	id	16G	Online	FC E-Port
10:00:00:05:1e:39:e4:5a "trunkmaster name" (Trunk master)								
751	3	31	7	-----	id	16G	Online	FC E-Port
10:00:00:05:1e:39:e4:5a "trunkmaster name" (Trunk master)								

Managing cables

Attention: The minimum bend radius should be no smaller than 10x the cable radius. The minimum bend radius for a 50 micron cable is 5 cm (2 in.) under full tensile load and 3 cm (1.2 in.) with no tensile load.

Note: Contact your IBM representative for options regarding different cable and patch panel configurations to simplify cable management with higher density FC8-64 port blades.

Cable management recommendations:

- Leave at least 1 m (3.28 ft) of slack for each port cable. This provides room to remove and replace blades in the chassis, allows for inadvertent movement of the rack, and helps prevent the cables from being bent to less than the minimum bend radius.

- If ISL Trunking is in use, group the cables by trunking group. The ports are color-coded to indicate which ports can be used in the same ISL Trunking group: eight ports marked with solid black ovals alternate with eight ports marked with oval outlines.
- Use only hook-and-loop fasteners for securing optical cables. Do not use cable ties. They can be easily overtightened and can damage the optical cables.
- For easier maintenance, label the fiber optic cables and record the devices to which they are connected.
- Use the cable management fingers attached to the rack rails to organize the cables off to the side of the chassis, and away from the chassis exhaust vents.
- Keep LEDs visible by routing port cables and other cables away from the LEDs.

For the procedure to install the ICL cables see “Removing and replacing inter-chassis link (QSFP) cables” on page 107.

Planning for encryption (optional)

Encryption is an optional feature available on the SAN768B-2 through the installation and use of the FS8-18 encryption blade. Advance planning is essential to achieve a successful implementation of encryption.

Attention: Setup of the FS8-18 blade for encryption requires the use of this document for the physical installation of the blade. Critical information required for enabling and managing encryption is contained in the *Fabric OS Encryption Administrator's Guide Supporting Tivoli Key Lifecycle Manager (TKLM) Environments*, which is included on the documentation CD-ROM that is shipped with the product. You must use both documents in order to successfully set up the switch for encryption.

Careful attention to details of setup and configuration are essential to enabling a secure encryption functionality. The following guidelines should be followed when planning for encryption with the 16-port encryption blade (FS8-18), which is available for the SAN768B-2 and SAN384B-2 products, or the SAN32B-E4.

- Redundancy of hardware is essential because if the encryption path is disrupted, access to the encrypted data will be lost with a single encryption device. You must have two encryption devices to ensure backup and access in the event that one of the devices goes down. If one of the devices in the encryption pair is not functioning, you will only have read access to the encrypted data on the functioning device until the non-functioning device is restored. Redundancy of hardware for encryption can be accomplished with the following options:
 - Two Key Vault locations on different devices
 - Two encryption devices in any combination of encryption switches (SAN32B-E4) and FS8-18 encryption blades (in SAN768B-2 or SAN384B-2 chassis)
- Cable planning for the encryption switch and its backup and for a primary and secondary key vault manager is critical. These devices can be separated by distance as long as they can maintain constant communication contact. One device must back up the other to ensure access to encrypted data. Refer to the *Fabric OS Encryption Administrator's Guide Supporting Tivoli Key Lifecycle Manager (TKLM) Environments* for more information on Master Keys (MK).
- Begin with a limited application of encryption in a test environment and once an expanded encryption test is successful, move the encryption into production
- Avoid dual encryption (Fabric encryption and device encryption). While this should not cause any encryption errors, it will degrade performance.

- There is no support of Cisco switches at this time by IBM. The section in the *Fabric OS Encryption Administrator's Guide Supporting Tivoli Key Lifecycle Manager (TKLM) Environments* related to Cisco Fabric connectivity does not currently apply.
- The use of Smart Cards provides additional encryption security management, and is highly recommended. Smart cards can be ordered as FRUs through IBM.
- The Top Talker feature is not compatible with redirection zones. The Top Talker feature should not be enabled when an encryption switch or blade is present in the fabric.
- Alias zoning is not supported in encryption environments. You must use the real WWPN.
- Refer to the "Steps for connecting to a TKLM appliance" section of the *Fabric OS Encryption Administrator's Guide Supporting Tivoli Key Lifecycle Manager (TKLM) Environments* for detailed information on initial setup. That section includes the following information:
 - All switches you plan to include in an encryption group must have a secure connection to the Tivoli Key Lifecycle Manager (TKLM). A local LINUX host must be available to transfer certificates.
 - Be sure that the clock time on the TKLM server and on the Brocade encryption nodes are the same. A difference of only a few minutes can cause the TLS connectivity to fail.
 - Repeat the same steps for configuring both the primary and the secondary key vault.
 - Both the primary and secondary key vaults should be registered before exporting MK or encrypting LUNs. If the secondary key vault is registered midway after encryption is done for some of the LUNs, then the key database should be backed up and restored on the secondary TKLM from the already registered primary TKLM before registering the secondary TKLM.
 - The following is a suggested order for the initial steps needed to create a secure connection to TKLM. (Refer to the "Steps for connecting to a TKLM appliance" section of the *Fabric OS Encryption Administrator's Guide Supporting Tivoli Key Lifecycle Manager (TKLM) Environments* for additional steps.)
 1. Initialize all encryption nodes to generate Key authentication center (KAC) certificates and export the signed KAC certificates to a local LINUX host.
 2. Obtain the necessary user credentials and log in to the TKLM server appliance from the TKLM management web console.

Configuring for encryption (optional)

Summary of procedure

The optional FS8-18 encryption blade requires configuration to enable the configuration functions. This section provides a brief overview of those configuration steps. Refer to the *Fabric OS Encryption Administrator's Guide Supporting Tivoli Key Lifecycle Manager (TKLM) Environments* for the detailed procedures to configure the encryption functions.

Note:

If the encryption blade (FS8-18) is being configured for the first time for encryption services, you will need to perform several pre-initialization tasks related to configuring the encryption node (switch), including:

- Generating the Critical Security Parameters (CSPs) and certificates

- Loading and setting up the certificates
- Establishing a trusted link (LKM Appliance)
- Configuring the global parameters and policies of the encryption group
- Generating and backing up the master key in RSA environments
- Handling key-vault high-availability
- Configuring cluster interconnect

After completing the pre-initialization tasks, you may need to perform several tasks related to configuring the encryption group. Figure 14 summarizes the flow of the encryption-configuration tasks.

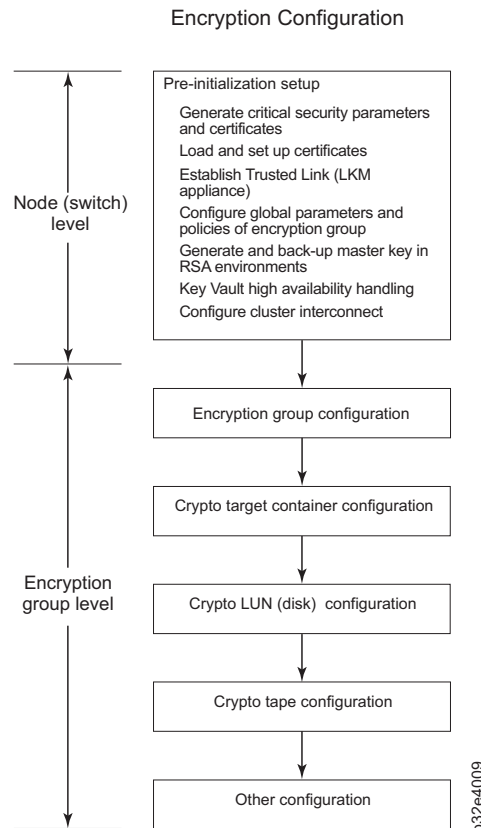

Figure 14. Encryption configuration

Avoid double encryption

Encryption and decryption at the storage device level does not affect the encryption switch or blade capabilities, and does not cause problems with decrypting the data. However, double encryption adds the unnecessary need to manage two sets of encryption keys, increases the risk of losing data, may reduce performance, and does not add security.

Verifying correct operation and backing up the configuration

To verify correct operation and to back up the system, follow these steps.

1. Check the LEDs to verify that all components are functional. For information about LED patterns, see Chapter 4, “Monitoring system components,” on page 53.
2. If necessary, log on to the switch by Telnet, using the **admin** account.

3. Verify the correct operation of the system by entering the **switchShow** command from the workstation. This command provides information about switch and port status.
4. Verify the correct operation of the SAN768B-2 in the fabric by entering the **fabricShow** command from the workstation. This command provides general information about the fabric.
5. To back up the configuration, run the following two steps:
 - a. Enter the **configupload -vf** command. This command uploads the system virtual fabric data.
 - b. Enter the **configupload** command. This command uploads the system configuration.
6. Run the following commands to see additional configuration information that you can then copy to a file to save:
 - **configShow**
 - **ipAddrShow**
 - **licenseShow**
 - **switchShow**

Alternatively, you can save the configuration file to the USB device by using the **usbstorage** command.

Note: Passwords are not saved in the configuration file, and are not uploaded during a **configUpload**. Password information should be saved in hardcopy in a secure location for emergency reference, subject to your security and password management policy.

Note: It is recommended that the configuration be backed up on a regular basis to ensure that a complete configuration is available for downloading to a replacement system.

Fabric OS firmware updates

To ensure optimum functioning of your system, IBM recommends operating your system with the latest Fabric OS version and firmware updates. Refer to the latest Fabric OS Release Notes and Interoperability Matrix for information regarding Fabric OS compatibility. This is particularly important for fabrics with 1-Gbps switches using earlier Fabric OS versions. Detailed information on downloading and installing firmware are provided in “Downloading firmware from an FTP server” on page 91 and “Downloading firmware from a USB drive” on page 93. More information can also be found in the *Fabric OS Administrator’s Guide*.

To access the appropriate matrix:

- Go to the IBM SAN web page www.ibm.com/systems/storage/san
- Select the **SAN768B-2 and SAN384B-2** product link
- On the displayed product page, click the **Interoperability Matrix** link in the **Learn more** section.

Firmware release notes and download files are available through the IBM Support Portal.

To view release notes and to download firmware:

- Go to the IBM Support Portal www.ibm.com/supportportal.

- Search for the product Machine type, 2499 or the product name.
- On the next page that is displayed, select **Download** under the **Task** section.
- From the displayed page, select the **Release notes** link. Review the release notes of the appropriate release version before installing the firmware update.
- Click the **Release Firmware** link and follow the online prompts to navigate to the **Brocade Downloads for IBM End Users** page.
- Follow the links and instructions on the Brocade pages. Note that associated FOS documentation can also be downloaded from this site.

Downloading and installing firmware

See “Downloading firmware from an FTP server” on page 91 and “Downloading firmware from a USB drive” on page 93 for detailed steps to download and install firmware on the CP blades.

1. The firmware version on both the active and backup CP blade should match, and should be at the latest level. If High Availability is enabled (**haEnable**), the system will automatically update the firmware level on both CP blades.
Attention: Firmware downloads require Ethernet connections to both CP blades. Procedures for downloading and installing firmware are fully described in the *Fabric OS Administrator’s Guide*.
2. When you have navigated to the appropriate download site, follow the online instructions on the displayed Fabric OS download pages, referring to the *Fabric OS Administrator’s Guide* as needed.
3. Enter **firmwareDownload -s** on your to download the firmware to one of the CP blades from your server.

Powering off the SAN768B-2

If you need to power off the system, follow these steps to avoid loss of data.

1. Shut down the system using the **sysShutdown** command.

```
switch::admin> sysshutdown
This command will shutdown the operating systems on your switch.
You are required to power-cycle the switch in order to restore operation.
Are you sure you want to shutdown the switch [y/n]? y
HA is disabled
Stopping blade 1
Shutting down the blade....
Stopping blade 4
Shutting down the blade....
Stopping blade 10
Shutting down the blade....
Broadcast message from root (pts/1) Tue Aug 23 14:23:06 2011...
The system is going down for system halt NOW !!
```
2. Power off the chassis by flipping the AC power switches on the power supplies to "O". The LEDs inside AC power switches should turn off. To maintain the ground connections, leave the power cords connected to the power supplies and to the electrical outlets.

Chapter 4. Monitoring system components

The SAN768B-2 is engineered for reliability and requires no routine operational steps or maintenance. This chapter provides information about determining the status of the following components using LEDs and CLI commands. Refer to the *Fabric OS Administrator's Guide* and the *Web Tools Administrator's Guide* for additional information.

There are two commands that can be especially helpful in monitoring the health of the SAN768B-2. These commands are **switchShow** and **chassisShow**. Examples of these commands are shown below. Note in the **switchShow** command the new switchType for the SAN768B-2 as well as the 16 Gbps speed identification for capable ports. The output has been truncated to reduce information duplication.

```
SAN768B-2_8 :root> switchshow
switchName: SAN768B-2_8
switchType: 120.3
switchState: Online
switchMode: Native
switchRole: Subordinate
switchDomain: 120
switchId: fffc78
switchWwn: 10:00:00:05:1e:d2:64:00
zoning: ON (BB)
switchBeacon: OFF
FC Router: ON
FC Router BB Fabric ID: 10
Address Mode: 0
Index Slot Port Address Media Speed State Proto
=====
  0    1    0   780000 id   N8   No_Light FC Disabled
(Switch not ready for EX_Ports)
  1    1    1   780100 id   N8   No_Light FC Disabled
(Switch not ready for EX_Ports)
  2    1    2   780200 --   N8   No_Module FC Disabled
(Switch not ready for EX_Ports)
  3    1    3   780300 --   N8   No_Module FC Disabled
(Switch not ready for EX_Ports)
  4    1    4   780400 id   N8   No_Light FC Disabled
(Switch not ready for EX_Ports)
  5    1    5   780500 id   N8   No_Light FC Disabled
(Switch not ready for EX_Ports)
  6    1    6   780600 id   N8   No_Light FC
  7    1    7   780700 id   4G   No_Light FC
  8    1    8   780800 --   N8   No_Module FC
  9    1    9   780900 --   N8   No_Module FC
 10    1   10   780a00 --   N8   No_Module FC
 11    1   11   780b00 --   N8   No_Module FC
 12    1   12   780c00 --   --   Offline VE Disabled (Persistent)
 13    1   13   780d00 --   --   Offline VE
 14    1   14   780e00 --   --   Offline VE
 15    1   15   780f00 --   --   Offline VE
128    1   16   788000 --   --   Offline VE
129    1   17   788100 --   --   Offline VE
130    1   18   788200 --   --   Offline VE
131    1   19   788300 --   --   Offline VE
132    1   20   788400 --   --   Offline VE
133    1   21   788500 --   --   Offline VE
134    1   22   788600 --   --   Offline VE Disabled (Persistent)
135    1   23   788700 --   --   Offline VE
136    1   24   788800 --   --   Offline VE
```

137	1	25	788900	--	--	Offline VE
138	1	26	788a00	--	--	Offline VE
139	1	27	788b00	--	--	Offline VE
140	1	28	788c00	--	--	Offline VE
141	1	29	788d00	--	--	Offline VE
142	1	30	788e00	--	--	Offline VE
143	1	31	788f00	--	--	Offline VE
	1	ge0		--	1G	No_Module FCIP Disabled (10G Mode)
	1	ge1		--	1G	No_Module FCIP Disabled (10G Mode)
	1	ge2		--	1G	No_Module FCIP Disabled (10G Mode)
	1	ge3		--	1G	No_Module FCIP Disabled (10G Mode)
	1	ge4		--	1G	No_Module FCIP Disabled (10G Mode)
	1	ge5		--	1G	No_Module FCIP Disabled (10G Mode)
	1	ge6		--	1G	No_Module FCIP Disabled (10G Mode)
	1	ge7		--	1G	No_Module FCIP Disabled (10G Mode)
	1	ge8		--	1G	No_Module FCIP Disabled (10G Mode)
	1	ge9		--	1G	No_Module FCIP Disabled (10G Mode)
	1	xge0		id	10G	No_Light FCIP
	1	xge1		id	10G	No_Light FCIP
32	3	0	782000	id	N8	No_Light FC
33	3	1	782100	id	N8	No_Light FC
34	3	2	782200	--	N8	No_Module FC
35	3	3	782300	id	N8	No_Light FC
36	3	4	782400	--	N8	No_Module FC
37	3	5	782500	--	N8	No_Module FC
38	3	6	782600	--	N8	No_Module FC
39	3	7	782700	--	N8	No_Module FC
40	3	8	782800	id	N8	No_Light FC
41	3	9	782900	id	N8	No_Light FC
42	3	10	782a00	--	N8	No_Module FC
43	3	11	782b00	--	N8	No_Module FC
44	3	12	782c00	id	N8	No_Light FC
45	3	13	782d00	id	N8	No_Light FC
46	3	14	782e00	--	N8	No_Module FC
47	3	15	782f00	--	N8	No_Light FC
165	3	21	78a500	--	N8	No_Module FC
166	3	22	78a600	id	N8	No_Light FC
167	3	23	78a700	--	N8	No_Module FC
168	3	24	78a800	--	N8	No_Module FC
169	3	25	78a900	id	N8	No_Light FC
170	3	26	78aa00	--	N8	No_Module FC
171	3	27	78ab00	--	N8	No_Module FC
172	3	28	78ac00	--	N8	No_Module FC
173	3	29	78ad00	--	N8	No_Module FC
174	3	30	78ae00	--	N8	No_Module FC
175	3	31	78af00	--	N8	No_Module FC
288	3	32	78a880	id	N8	No_Light FC
289	3	33	78a980	id	N8	No_Light FC
290	3	34	78aa80	id	N8	No_Light FC
291	3	35	78ab80	id	N8	No_Light FC
292	3	36	78ac80	id	N8	No_Light FC
293	3	37	78ad80	id	N8	No_Light FC
294	3	38	78ae80	id	N8	No_Light FC
295	3	39	78af80	id	N8	No_Light FC
296	3	40	78a080	id	N8	No_Light FC
297	3	41	78a180	--	N8	No_Module FC
298	3	42	78a280	--	N8	No_Module FC
299	3	43	78a380	--	N8	No_Module FC
300	3	44	78a480	--	N8	No_Module FC
301	3	45	78a580	--	N8	No_Module FC
302	3	46	78a680	--	N8	No_Module FC
303	3	47	78a780	--	N8	No_Module FC
800	3	48	782080	id	N8	No_Light FC
801	3	49	782180	--	N8	No_Module FC
802	3	50	782280	--	N8	No_Module FC
803	3	51	782380	id	N8	No_Light FC
804	3	52	782480	--	N8	No_Module FC

805	3	53	782580	--	N8	No_Module FC
806	3	54	782680	--	N8	No_Module FC
807	3	55	782780	id	N8	No_Light FC
808	3	56	782880	--	N8	No_Module FC
809	3	57	782980	--	N8	No_Module FC
810	3	58	782a80	--	N8	No_Module FC
811	3	59	782b80	--	N8	No_Module FC
812	3	60	782c80	--	N8	No_Module FC
813	3	61	782d80	--	N8	No_Module FC
814	3	62	782e80	--	N8	No_Module FC
815	3	63	782f80	--	N8	No_Module FC
48	4	0	783000	id	N8	No_Light FC
49	4	1	783100	id	N8	No_Light FC
50	4	2	783200	id	N8	No_Light FC
51	4	3	783300	id	N8	No_Light FC
52	4	4	783400	id	N8	No_Light FC
53	4	5	783500	id	N8	No_Light FC
54	4	6	783600	id	N8	No_Light FC
55	4	7	783700	id	N8	No_Light FC
56	4	8	783800	id	N8	No_Light FC
57	4	9	783900	id	N8	No_Light FC
58	4	10	783a00	id	N8	No_Light FC
59	4	11	783b00	id	N8	No_Light FC
60	4	12	783c00	id	N8	No_Light FC
61	4	13	783d00	id	N8	No_Light FC
62	4	14	783e00	id	N8	No_Light FC
63	4	15	783f00	id	N8	No_Light FC
176	4	16	78b000	id	N8	No_Light FC
177	4	17	78b100	id	N8	No_Light FC
178	4	18	78b200	id	N8	No_Light FC
179	4	19	78b300	id	N8	No_Light FC
180	4	20	78b400	id	N8	No_Light FC
181	4	21	78b500	id	N8	No_Light FC
182	4	22	78b600	id	N8	No_Light FC
183	4	23	78b700	id	AN	No_Sync FC
184	4	24	78b800	--	N16	No_Module FC
185	4	25	78b900	--	N16	No_Module FC
186	4	26	78ba00	--	N16	No_Module FC
187	4	27	78bb00	--	N16	No_Module FC
188	4	28	78bc00	id	N8	No_Light FC
189	4	29	78bd00	id	N8	No_Light FC
190	4	30	78be00	id	N8	No_Light FC
190	4	30	78be00	id	N8	No_Light FC
191	4	31	78bf00	id	N8	No_Light FC
304	4	32	78b880	--	N16	No_Module FC
305	4	33	78b980	--	N16	No_Module FC
306	4	34	78ba80	--	N16	No_Module FC
307	4	35	78bb80	--	N16	No_Module FC
308	4	36	78bc80	--	N16	No_Module FC
309	4	37	78bd80	--	N16	No_Module FC
310	4	38	78be80	id	N8	No_Light FC
311	4	39	78bf80	id	N8	No_Light FC
312	4	40	78b080	--	N16	No_Module FC
313	4	41	78b180	--	N16	No_Module FC
314	4	42	78b280	--	N16	No_Module FC
315	4	43	78b380	--	N16	No_Module FC
316	4	44	78b480	--	N16	No_Module FC
317	4	45	78b580	id	N16	No_Light FC
318	4	46	78b680	id	N16	No_Light FC
319	4	47	78b780	id	N16	Online FC E-Port
10:00:00:05:33:03:2c:00 "DCX4S_130" (upstream)						
384	5	0	-----	--	16G	No_Module FC
385	5	1	-----	--	16G	No_Module FC
386	5	2	-----	--	16G	No_Module FC
387	5	3	-----	--	16G	No_Module FC
388	5	4	-----	--	16G	No_Module FC
389	5	5	-----	--	16G	No_Module FC

390	5	6	-----	--	16G	No_Module	FC
391	5	7	-----	--	16G	No_Module	FC
392	5	8	-----	--	16G	No_Module	FC
393	5	9	-----	--	16G	No_Module	FC
394	5	10	-----	--	16G	No_Module	FC
395	5	11	-----	--	16G	No_Module	FC
396	5	12	-----	id	16G	No_SigDet	FC
397	5	13	-----	id	16G	No_SigDet	FC
398	5	14	-----	id	16G	No_SigDet	FC
399	5	15	-----	id	16G	No_SigDet	FC
400	5	16	-----	id	16G	No_SigDet	FC
401	5	17	-----	id	16G	No_SigDet	FC
402	5	18	-----	id	16G	No_SigDet	FC
403	5	19	-----	id	16G	No_SigDet	FC
404	5	20	-----	id	16G	No_SigDet	FC
405	5	21	-----	id	16G	No_SigDet	FC
406	5	22	-----	id	16G	No_SigDet	FC
407	5	23	-----	id	16G	No_SigDet	FC
408	5	24	-----	id	16G	No_SigDet	FC
409	5	25	-----	id	16G	No_SigDet	FC
410	5	26	-----	id	16G	No_SigDet	FC
411	5	27	-----	id	16G	No_SigDet	FC
412	5	28	-----	id	16G	No_SigDet	FC
413	5	29	-----	id	16G	No_SigDet	FC
414	5	30	-----	id	16G	No_SigDet	FC
415	5	31	-----	id	16G	No_SigDet	FC
1152	5	32	-----	--	16G	No_Module	FC
1153	5	33	-----	--	16G	No_Module	FC
1154	5	34	-----	--	16G	No_Module	FC
1155	5	35	-----	--	16G	No_Module	FC
1156	5	36	-----	--	16G	No_Module	FC
1157	5	37	-----	--	16G	No_Module	FC
1158	5	38	-----	--	16G	No_Module	FC
1159	5	39	-----	--	16G	No_Module	FC
1160	5	40	-----	--	16G	No_Module	FC
1161	5	41	-----	--	16G	No_Module	FC
1162	5	42	-----	--	16G	No_Module	FC
1163	5	43	-----	--	16G	No_Module	FC
1164	5	44	-----	--	16G	No_Module	FC
1165	5	45	-----	--	16G	No_Module	FC
1166	5	46	-----	--	16G	No_Module	FC
1167	5	47	-----	--	16G	No_Module	FC
1168	5	48	-----	--	16G	No_Module	FC
1169	5	49	-----	--	16G	No_Module	FC
1170	5	50	-----	--	16G	No_Module	FC
1171	5	51	-----	--	16G	No_Module	FC
1172	5	52	-----	--	16G	No_Module	FC
1173	5	53	-----	--	16G	No_Module	FC
1174	5	54	-----	--	16G	No_Module	FC

```
<output truncated>
SAN768B-2_8 :root>
```

Note with the **chassisShow** command, the Chassis Family designation for the SAN768B-2 along with specific information about every field-replaceable unit in the chassis is displayed.

```
SAN768B-2_8:root> chassisshow
Chassis Family: SAN768B-2
Chassis Backplane Revision: 0

AP BLADE Slot: 1
Header Version: 2
Power Consume Factor: -250
Factory Part Num: 60-1001157-21
Factory Serial Num: ATM0427F01F
Manufacture: Day: 12 Month: 7 Year: 2011
```

Update: Day: 27 Month: 9 Year: 2011
Time Alive: 45 days
Time Awake: 0 days

SW BLADE Slot: 3
Header Version: 2
Power Consume Factor: -130
Factory Part Num: 60-0000071-07
Factory Serial Num: BAH0344E01G
Manufacture: Day: 2 Month: 11 Year: 2010
Update: Day: 7 Month: 4 Year: 2011
Time Alive: 280 days
Time Awake: 0 days

SW BLADE Slot: 4
Header Version: 2
Power Consume Factor: -160
Power Usage (Watts): -100
Factory Part Num: 60-1002144-02
Factory Serial Num: BQB0349F00G
Manufacture: Day: 10 Month: 12 Year: 2010
Update: Day: 28 Month: 3 Year: 2011
Time Alive: 14 days
Time Awake: 0 days

CP BLADE Slot: 6
Header Version: 2
Power Consume Factor: -40
Factory Part Num: 60-1000376-08
Factory Serial Num: AHJ0449E042
Manufacture: Day: 14 Month: 12 Year: 2010
Update: Day: 28 Month: 3 Year: 2011
Time Alive: 299 days
Time Awake: 0 days

CP BLADE Slot: 7
Header Version: 2
Power Consume Factor: -40
Factory Part Num: 60-1000376-08
Factory Serial Num: AHJ0448E0AK
Manufacture: Day: 15 Month: 12 Year: 2010
Update: Day: 28 Month: 3 Year: 2011
Time Alive: 312 days
Time Awake: 0 days

CORE BLADE Slot: 5
Header Version: 2
Power Consume Factor: -240
Power Usage (Watts): -154
Factory Part Num: 60-1002140-02
Factory Serial Num: BPZ0349F00G
Manufacture: Day: 7 Month: 12 Year: 2010
Update: Day: 28 Month: 3 Year: 2011
Time Alive: 49 days
Time Awake: 0 days

CORE BLADE Slot: 8
Header Version: 2
Power Consume Factor: -240
Power Usage (Watts): -148
Factory Part Num: 60-1002140-02
Factory Serial Num: BPZ0349F006
Manufacture: Day: 7 Month: 12 Year: 2010
Update: Day: 28 Month: 3 Year: 2011
Time Alive: 46 days
Time Awake: 0 days

SW BLADE Slot: 11
Header Version: 2
Power Consume Factor: -160
Power Usage (Watts): -115
Factory Part Num: 60-1002144-02
Factory Serial Num: BQB0345F00T
Manufacture: Day: 11 Month: 11 Year: 2010
Update: Day: 28 Month: 3 Year: 2011
Time Alive: 30 days
Time Awake: 0 days

SW BLADE Slot: 12
Header Version: 2
Power Consume Factor: -160
Power Usage (Watts): -79
Factory Part Num: 60-1002144-02
Factory Serial Num: BQB0345F012
Manufacture: Day: 20 Month: 11 Year: 2010
Update: Day: 28 Month: 3 Year: 2011
Time Alive: 3 days
Time Awake: 0 days

POWER SUPPLY Unit: 1
Header Version: 2
Power Consume Factor: 2000
Factory Part Num: 23-0000067-01
Factory Serial Num: AGC2M44EKPH
Manufacture: Day: 29 Month: 12 Year: 2010
Update: Day: 28 Month: 3 Year: 2011
Time Alive: 319 days
Time Awake: 0 days

POWER SUPPLY Unit: 3
Header Version: 2
Power Consume Factor: 2000
Factory Part Num: 23-0000067-01
Factory Serial Num: AGC2M44EKPL
Manufacture: Day: 29 Month: 12 Year: 2010
Update: Day: 28 Month: 3 Year: 2011
Time Alive: 319 days
Time Awake: 0 days

FAN Unit: 1
Header Version: 2
Power Consume Factor: -126
Factory Part Num: 60-1000384-09
Factory Serial Num: AGB0652E0HA
Manufacture: Day: 29 Month: 12 Year: 2010
Update: Day: 28 Month: 3 Year: 2011
Time Alive: 319 days
Time Awake: 0 days

FAN Unit: 2
Header Version: 2
Power Consume Factor: -126
Factory Part Num: 60-1000384-09
Factory Serial Num: AGB0652E0H9
Manufacture: Day: 29 Month: 12 Year: 2010
Update: Day: 28 Month: 3 Year: 2011
Time Alive: 319 days
Time Awake: 0 days

FAN Unit: 3
Header Version: 2
Power Consume Factor: -126
Factory Part Num: 60-1000384-09
Factory Serial Num: AGB0652E0H8

Manufacture: Day: 29 Month: 12 Year: 2010
Update: Day: 28 Month: 3 Year: 2011
Time Alive: 319 days
Time Awake: 0 days

WWN Unit: 1
Header Version: 2
Power Consume Factor: -1
Factory Part Num: 60-1000491-05
Factory Serial Num: AFX0602F001
Manufacture: Day: 29 Month: 12 Year: 2010
Update: Day: 28 Month: 3 Year: 2011
Time Alive: 319 days
Time Awake: 0 days
ID: BRD0000CA
Part Num: SLKWRM0000DCX

WWN Unit: 2
Header Version: 2
Power Consume Factor: -1
Factory Part Num: 60-1000491-05
Factory Serial Num: AJX0446E009
Manufacture: Day: 29 Month: 12 Year: 2010
Update: Day: 28 Month: 3 Year: 2011
Time Alive: 319 days
Time Awake: 0 days

Chassis Factory Serial Num: AFY0601F007
SAN768B-2_8:root>

The status of blades, power supplies, blower assemblies, and WWN cards can be verified through the following procedures.

- “Port, application, or encryption blade status”
- “Control processor blade (CP8) status” on page 68
- “Core switch blade (CR16-8) status” on page 70
- “Power supply status” on page 72
- “Blower assembly status” on page 73
- “WWN bezel and WWN card status” on page 75

Port, application, or encryption blade status

To determine the status of a port, application, or encryption blade:

1. Check the LEDs on the blade.
 - Figure 15 on page 60 illustrates the FC16-32 port blade.
 - Figure 16 on page 61 illustrates the FC16-48 port blade.
 - Figure 17 on page 62 illustrates the FC8-32E port blade.
 - Figure 18 on page 63 illustrates the FC8-48E port blade.
 - Figure 19 on page 64 illustrates the FC8-64 port blade.
 - Figure 20 on page 65 illustrates the FS8-18 encryption blade
 - Figure 21 on page 66 illustrates the FX8-24 extension blade
2. The LED patterns may temporarily change during POST and other diagnostic tests. For information about how to interpret the LED patterns, see Table 6 on page 67, which describes the port, application, and routing blade LED patterns and the recommended actions for those patterns.
3. Check the blade status by entering **slotShow**.

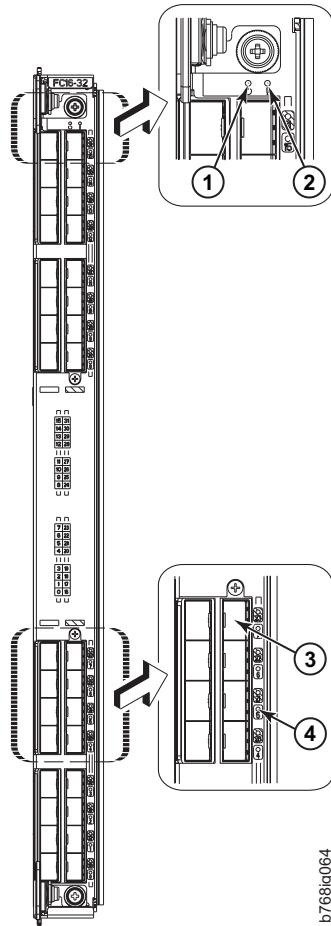

b768ig064

Figure 15. FC16-32 port blade

- | | |
|--|--|
| <p>1 Power LED</p> <p>2 Status LED</p> | <p>3 Fibre Channel port</p> <p>4 Port status LED</p> |
|--|--|

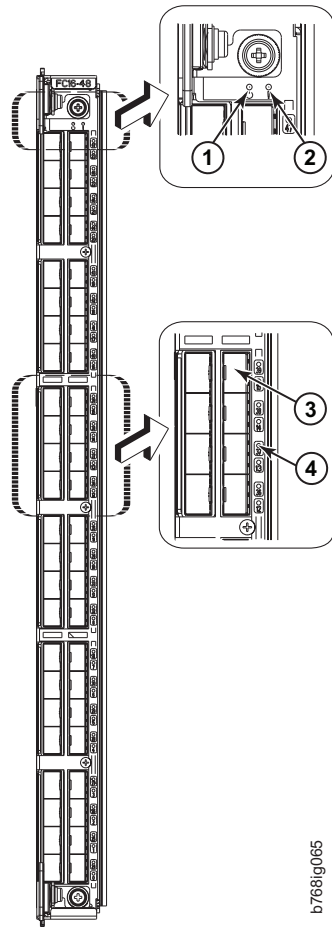

b768ig065

Figure 16. FC16-48 port blade

- 1** Power LED
- 2** Status LED

- 3** Fibre Channel port
- 4** Port status LED

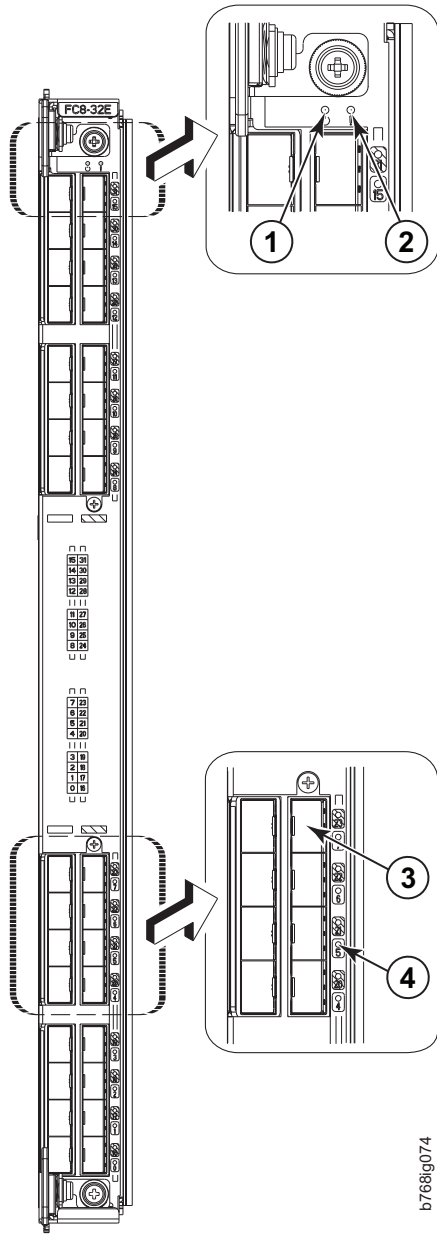

b768g074

Figure 17. FC8-32E port blade

- | | |
|---|---|
| <ul style="list-style-type: none"> 1 Power LED 2 Status LED | <ul style="list-style-type: none"> 3 Fibre Channel port 4 Port status LED |
|---|---|

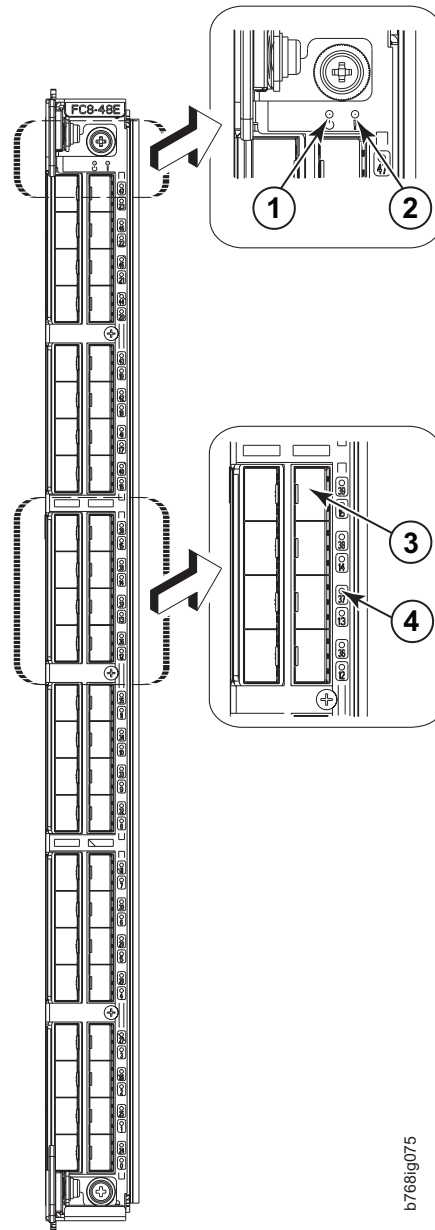

b768ig075

Figure 18. FC18-48E port blade

- 1** Power LED
- 2** Status LED

- 3** Fibre Channel port
- 4** Port status LED

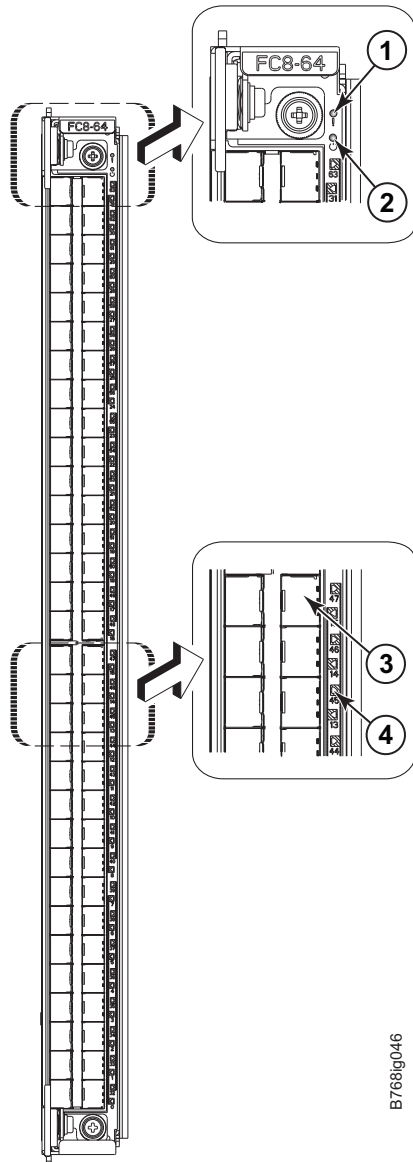

B768g046

Figure 19. FC8-64 port blade

- | | | | |
|----------|------------|----------|--------------------|
| 1 | Status LED | 3 | Fibre Channel port |
| 2 | Power LED | 4 | Port status LED |

Note: The FC8-64 port blade requires narrower OM-3 LC cables.

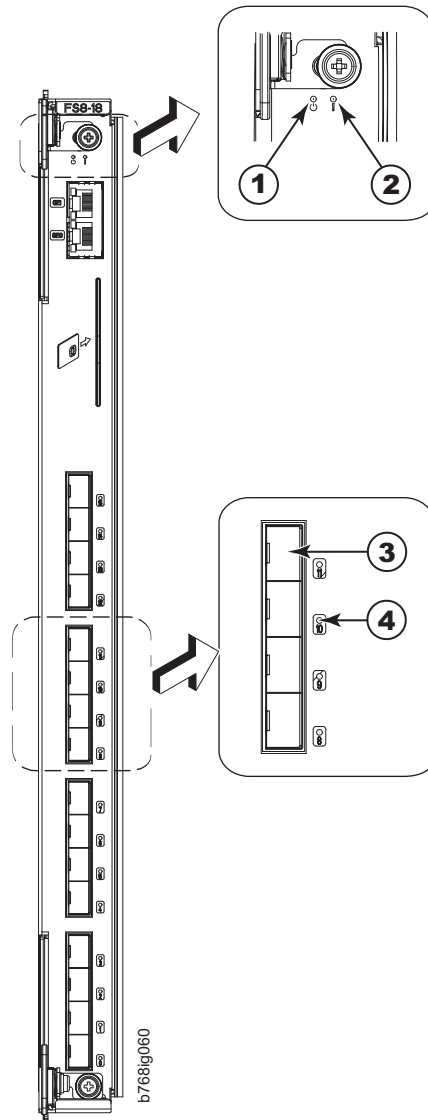
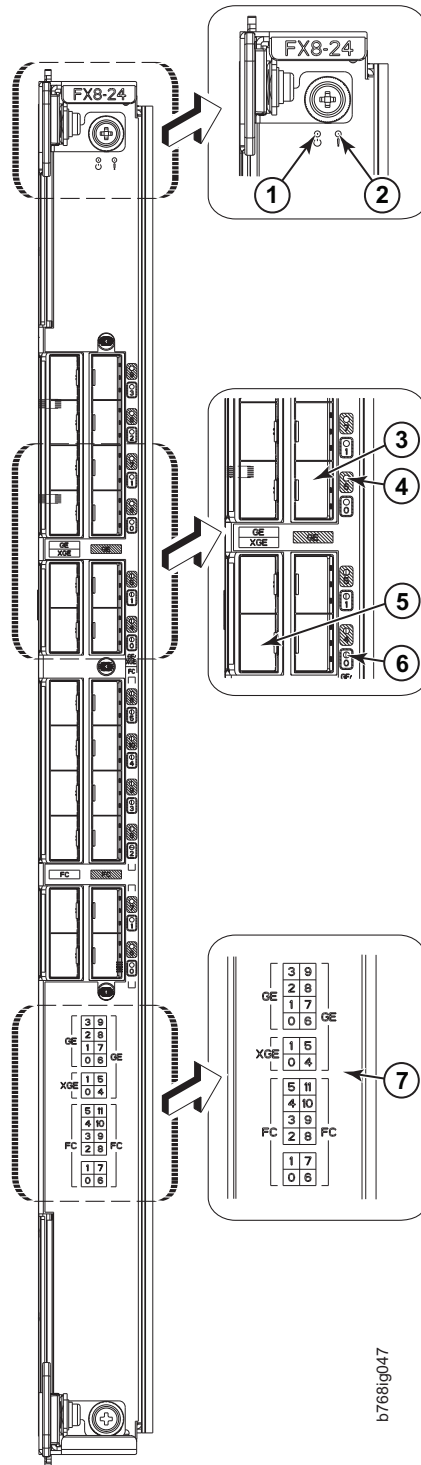

Figure 20. FS8-18 encryption blade

- 1** Power LED
- 2** Status LED

- 3** Fibre Channel port
- 4** Port status LED



b7688g047

Figure 21. FX8-24 extension blade

- | | | | | | |
|----------|------------|----------|-------------------|----------|----------|
| 1 | Power LED | 4 | GbE port 6 LED | 7 | Port map |
| 2 | Status LED | 5 | 10 GbE port 0 | | |
| 3 | GbE port 6 | 6 | 10 GbE port 0 LED | | |

See “FX8-24 blade” on page 151 for information about trunking groups on this blade.

Table 6 describes the port and application blade LED patterns and the recommended actions for those patterns.

Table 6. Port, application, and encryption blade LED descriptions

LED purpose	Color	Status	Recommended action
Blade power LED	Steady green	Blade is enabled.	No action required.
	No light (LED is off)	Blade is not powered on.	Ensure that the blade is firmly seated and either the thumbscrew is fully engaged or the slider is pushed up and the ejectors are fully engaged.
Blade status LED	No light (LED is off)	Blade is either healthy or does not have power.	Verify that the power LED is on.
	Steady amber	Blade is faulty.	Ensure blade is firmly seated and check status by entering the slotShow command. If LED remains amber, contact IBM.
	Slow-flashing amber (on 2 seconds, then off 2 seconds)	Blade is not seated correctly or is faulty.	Pull blade out and reseal it. If the LED continues to flash, replace the blade.
	Fast-flashing amber (on 1/2 second, then off 1/2 second)	Environmental range exceeded.	Check for out-of-bounds environmental condition and correct it.

Table 6. Port, application, and encryption blade LED descriptions (continued)

LED purpose	Color	Status	Recommended action
FC port status	No light (LED is off)	Port has no incoming power, or there is no light or signal carrier detected.	Verify that the power LED is on, check the transceiver and cable.
		Polling is in progress.	Allow 60 seconds for polling to complete.
		Connected device is configured in an offline state.	Verify the status of the connected device.
	Steady green	Port is online (connected to an external device) but has no traffic.	No action required.
	Slow-flashing green (on 1 second, then off 1 second)	Port is online but segmented, indicating a loopback plug or cable or an incompatible switch.	Verify that the correct device is attached to the SAN768B-2.
	Fast-flashing green (on 1/4 second, then off 1/4 second)	Port is in internal loopback (diagnostic).	No action required.
	Flickering green	Port is online, with traffic flowing through port.	No action required.
	Steady amber	Port is receiving light or signal carrier, but it is not online yet.	Reset the port from the workstation using the portEnable or portCfgPersistentEnable command.
	Slow-flashing amber (on 2 seconds, then off 2 seconds)	Port is disabled due to diagnostic tests or portDisable or portCfgPersistentEnable command.	Reset the port from the workstation using the portEnable or portCfgPersistentEnable command.
	Fast-flashing amber (on 1/2 second, then off 1/2 second)	Transceiver or port is faulty.	Change the transceiver or reset the switch from the workstation.
Alternating green/amber	Port is bypassed	Reset port from workstation using the portEnable or portCfgPersistentEnable command.	
GbE port status (FX8-24) - both 1 GbE and 10 GbE ports	No light (LED is off)	Port has no incoming power, or there is no light or signal carrier detected.	Verify that the power LED is on, check the transceiver and cable.
	Steady green	Port is online but has no traffic.	No action required.
	Slow-flashing green (on 1 second, then off 1 second)	Beacon. Used to identify specific ports.	No action required.
	Flickering green	Port is online, with traffic flowing through port.	No action required.
	Fast-flashing amber (on 1/4 second, then off 1/4 second)	Transceiver or port is faulty.	Change the transceiver or reset the switch from the workstation.

Control processor blade (CP8) status

Complete the following steps to determine the status of a CP blade.

1. Check the LED indicators on the CP blade (see Figure 22 on page 69). The LED patterns may temporarily change during POST and other diagnostic tests. For information about how to interpret the LED patterns, see Table 7 on page 70.
2. Check port blade status by typing **slotShow** and **haShow**.

Figure 22 identifies the control processor blade (CP8) and its components.

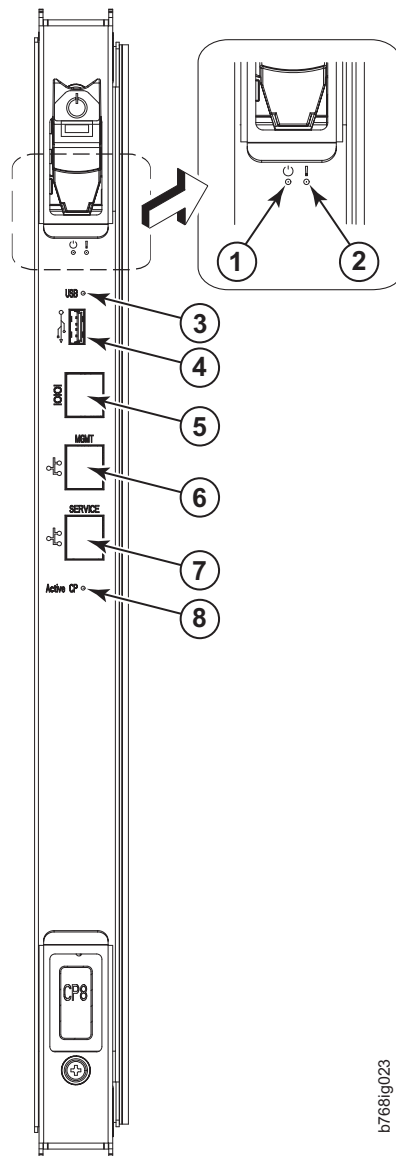

b7681g023

Figure 22. Control processor blade (CP8) components

- | | | | |
|----------|------------|----------|----------------------------|
| 1 | Power LED | 5 | Console port (10101) |
| 2 | Status LED | 6 | Ethernet port (MGMT IP) |
| 3 | USB LED | 7 | Ethernet port (SERVICE IP) |
| 4 | USB port | 8 | Active CP LED |

Table 7. CP8 blade LED descriptions

LED purpose	Color	Status	Recommended Action
Power	Steady green	CP blade is on.	No action required.
	No light (LED is off)	CP blade is not on.	Ensure blade is firmly seated and has power.
Status	No light (LED is off)	CP blade is either healthy or does not have power.	Verify that the power LED is on.
	Steady amber	CP blade is faulty or the switch is still booting.	Ensure blade is firmly seated and switch has completed booting. If LED remains amber, contact IBM.
	Slow-flashing amber (on 2 seconds; then off 2 seconds)	CP blade is not seated correctly or is faulty.	Pull blade out and reseal it. If LED continues to flash, replace the blade.
	Fast-flashing amber (on 1/2 second; then off 1/2 second)	Environmental range exceeded.	Check for out-of-bounds environmental condition and correct it.
Ethernet link status	No light (LED is off)	Either an Ethernet link is not detected, or it does not have incoming power.	Ensure the blade has power, Ethernet cable is firmly seated, and connected device is functioning.
	Flickering green/amber	Ethernet link is healthy and traffic is flowing through port.	No action required.
Ethernet link speed	No light (LED is off)	Ethernet link speed is 10 Mbps or CP blade does not have incoming power	Ensure CP has power. Note: To force a persistent Ethernet link speed, type the ifModeSet command.
	Steady green	Ethernet link speed is 100/1000 Mbps	No action required.
USB Status	LED is on	USB device is enabled	No action required.
	LED is off	USB device is not present or disabled.	No action required.
Active CP	Steady blue	Active CP blade.	No action required.
	No light (LED is off)	Standby CP blade.	No action required.

Core switch blade (CR16-8) status

Complete the following steps to determine the status of a core switch (CR16-8) blade.

1. Check the LED indicators on the core switch blade (Figure 23). The LED patterns may temporarily change during POST and other diagnostic tests; for information about how to interpret the LED patterns, see Table 8.
2. Check core switch blade status by typing `slotShow` and `haShow`.

Figure 23 identifies the core switch blade and its components

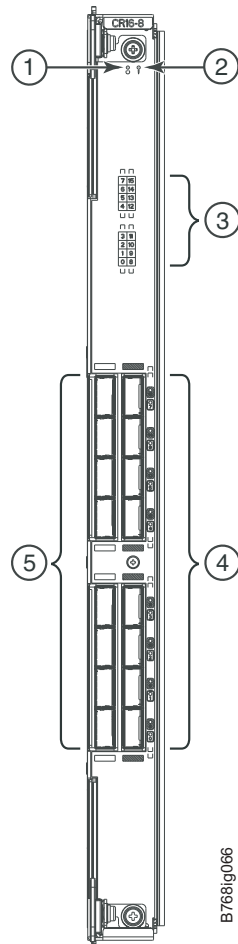

Figure 23. Core switch blade (CR16-8), LEDs and QSFP connectors

- | | | | |
|----------|------------------------------------|----------|----------------------------|
| 1 | Power LED | 4 | QSFP connectors |
| 2 | Status LED | 5 | QSFP connector status LEDs |
| 3 | QSFP port map and trunking diagram | | |

Table 8. CR16-8 blade LED descriptions

LED purpose	Color	Status	Recommended Action
Power	Steady green	CR16-8 blade is on	No action required.
	No light (LED is off)	CR16-8 blade is not on	Ensure that the blade is firmly seated and has power.

Table 8. CR16-8 blade LED descriptions (continued)

LED purpose	Color	Status	Recommended Action
Status	No light (LED is off)	CR16-8 blade is either healthy or does not have power.	Verify that the power LED is on.
	Steady amber	CR16-8 blade is faulty or the system is still booting.	Ensure that the blade is firmly seated and the system has completed booting. If LED remains amber, contact IBM.
	Slow-flashing amber (on 2 seconds; then off 2 seconds)	CR16-8 blade is not seated correctly or is faulty.	Pull blade out and reset it. If LED continues to flash, replace blade.
	Fast-flashing amber (on 1/2 second; then off 1/2 second)	Environmental range exceeded.	Check for out-of-bounds environmental condition and correct it.
QSFP connector status LED	No light (LED is off)	No QSFP module, all four QSFP ports are disabled	No action needed if the QSFP is not installed or verify that the QSFP is fully inserted.
	Steady amber	QSFP module is in, all four ports have no signal/no sync.	Ensure that the cable is properly connected. If the LED remains amber, contact IBM.
	Blinking amber	Port is disabled or faulted, FC link activity, segmented, loopback mode, also during transition between cable plug in and all four ports online.	Check for console messages or wait for all four ports to come online.
	Steady green	QSFP module is in and all ports are online.	No action needed.

Power supply status

Complete the following steps to determine the status of a power supply.

1. Check the LED indicator on the power supply (see Figure 24 on page 73). The LED patterns may temporarily change during POST and other diagnostic tests; for information about how to interpret the LED patterns, see Table 9 on page 73.
2. Check the power supply status by entering **psShow**. The power supply status displays OK, Absent, or Faulty. If a power supply displays absent or faulty, contact IBM. Both physically absent or faulty could also be the result of the power supply not being properly seated or being turned off.

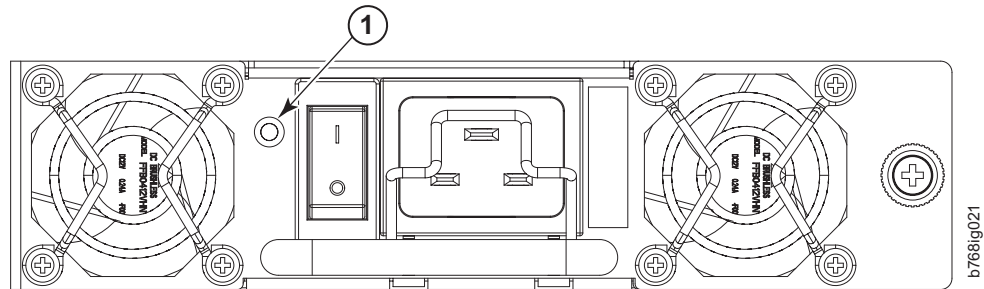

Figure 24. Power supply LEDs

1 Power LED

Table 9. Power supply LED descriptions

LED purpose	Color	Status	Recommended Action
Power	No light (LED is off)	Power supply does not have incoming power and is not providing power to the system.	Ensure power supply is firmly seated, the system has incoming power, both power cables are connected, and AC power switches are on.
	Steady green	Power supply has incoming power and is providing power to the system.	No action required.
	Flashing green	Power supply is about to fail.	Replace the power supply.

Blower assembly status

Complete the following steps to determine the status of a blower assembly.

1. Check the LED indicators on the blower assembly (see Figure 25 on page 74). The LED patterns may temporarily change during POST and other diagnostic tests; for information about how to interpret the LED patterns, see Table 10 on page 74. The system has three blower assembly modules. Be sure to check each module.
2. Check the blower assembly status using the **fanShow** command.
The status for each blower assembly displays OK, Absent, or Faulty. The RPM of each fan in the assembly is also provided. If a blower assembly is absent or faulty, contact IBM. Both physically absent or faulty could also be the result of the blower assembly not being properly seated or being turned off.

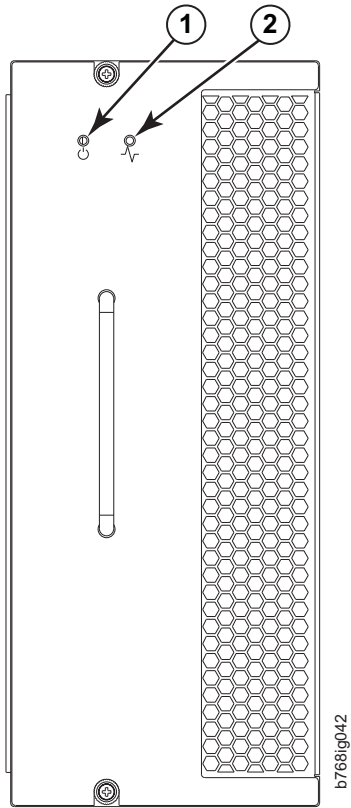

Figure 25. Blower assembly LEDs

Item Description

- 1** Power LED
- 2** Fault LED

Table 10. Blower assembly LED descriptions

LED purpose	Color	Status	Recommended action
Power	No Light (LED is off)	Blower assembly does not have power.	Ensure that the blower assembly is firmly seated and has power.
	Steady green	Blower assembly has power.	No action required.

Table 10. Blower assembly LED descriptions (continued)

LED purpose	Color	Status	Recommended action
Fault	No Light (LED is off)	Blower assembly is either healthy or does not have power.	Ensure that the blower assembly has power.
	Steady amber	Blower assembly has a failure (full or partial).	Replace the blower assembly.
	Slow-flashing amber (on 2 seconds, then off 2 seconds)	Blower assembly is not seated correctly or is faulty.	Pull the unit out and reseal it. If the LED continues to flash, replace the unit.
	Flashing amber (on 1/2 second, then off 3.5 second)	Fan is disabled.	Run the fanEnable command to enable the fan.
	Fast-flashing amber (on 1/2 second, then off 1/2 second)	Environmental range exceeded.	Check for out-of-bounds environmental condition, resolve any problems, and reseal the unit. If the LED continues to flash, replace the unit.

WWN bezel and WWN card status

Complete the following steps to determine the status of the WWN card.

1. Enter the **chassisShow** command to display information about the WWN card. (WWN units correspond to information specific to the WWN card.) Error messages that may indicate problems with a WWN card are summarized in Table 11.

Table 11. Messages that may indicate WWN card failure

Type of Message	Sample error message
WWN unit fails its FRU (field replaceable unit) header access.	0x24c (fabos): Switch: switchname, error EM-I2C_TIMEOUT, 2, WWN 1 I2C timed out: state 0x4
WWN unit fails to power on	<timestamp>, [EM-1004], <sequence-number>,,CRITICAL, <system-name>, WWN # failed to power on or <timestamp>, [EM-1043], <sequence-number>,, WARNING, <system-name>, Can't power <FRU Id> <state (on or off)>

Table 11. Messages that may indicate WWN card failure (continued)

Type of Message	Sample error message
WWN unit is being faulted.	0x24c (fabos): Switch: switchname, Critical EM-WWN_UNKNOWN, 1, Unknown WWN #2 is being faulted or <timestamp>, [EM-1003], 40, SLOT 7 FFDC CHASSIS, CRITICAL, SAN768-2, WWN 2 has unknown hardware identifier: FRU faulted or <timestamp>, [EM-1034], <sequence-number>,, ERROR, <system-name>, WWN # set to faulty, rc=<return code>
WWN unit is not present or is not accessible.	0x24c (fabos): Switch: switchname, Error EM-WWN_ABSENT, 2, WWN #1 not present or <timestamp>, [EM-1036], <sequence-number>,, WARNING, <system-name>, <FRU Id> is not accessible.
Writing to the FRU history log (hilSetFruHistory) has failed.	0x24c (fabos): Switch: switchname, Error EM-HIL_FAIL, 2, HIL Error: hilSetFruHistory failed, rc=-3 for SLOT 3
WWN unit insertion was detected	<timestamp> [EM-1049], <sequence-number>,, INFO, <system-name>, FRU WWN # insertion detected.
WWN unit removal was detected	<timestamp> [EM-1050], <sequence-number>,, INFO, <system-name>, FRU WWN # removal detected.

2. Check the LED indicators on the WWN bezel and verify that they reflect the actual status of the components. The WWN bezel covers the WWN cards and allows its LEDs to shine through (see Figure 26 on page 77). The LEDs on the WWN bezel provide a consolidated view of the port, CP, and CR blade status (see Table 12).

Table 12. WWN LED patterns

LED location/purpose	Color	Status	Recommended action
Port blade/CP/CR blade power	Steady green .	Power is OK.	No action required
Port blade/CP/CR blade status	Steady amber	Card is faulty.	Check card.
	No light (LED is off)	Card is OK.	No action required.

Note: If a blade slot has a filler panel installed, the corresponding LEDs on the WWN card do not light up

Note: If a status LED on the WWN bezel flashes, the power LED on the WWN bezel also flashes, for increased visibility.

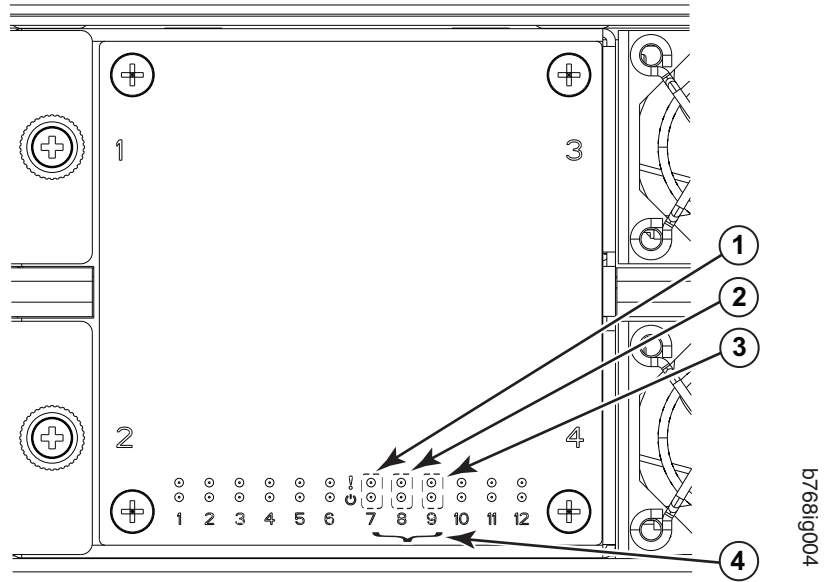

Figure 26. LEDs on the WWN card and bezel

- | | |
|---|---|
| <p>1 CP blade Status (above) and Power (below) LEDs</p> <p>2 CR blade Status (above) and Power (below) LEDs</p> | <p>3 Port blade Status (above) and Power (below) LEDs</p> <p>4 Slot numbers</p> |
|---|---|

Chapter 5. Removing and installing components

Attention: Read the safety notices before servicing (see “Safety notices and labels” on page xiii).

The field replaceable units (FRUs) in the SAN768B-2 can be removed and installed without special tools. The SAN768B-2 can continue operating during many of the FRU replacements if the conditions specified in the procedure are followed.

This chapter contains the following component removal and installation procedures.

- “Removing and installing the chassis door”
- “Removing and installing a cable management comb” on page 80
- “Removing and installing port, application, and encryption blades” on page 81
- “Removing and installing blade filler panels” on page 84
- “Removing and installing a CP8 control processor blade” on page 85
- “Removing and installing a core switch blade (CR16-8)” on page 95
- “Removing and installing a power supply” on page 98
- “Removing and installing a blower assembly” on page 100
- “Removing and installing a WWN bezel and WWN card” on page 101
- “Removing and installing transceivers” on page 104
- “Removing and replacing inter-chassis link (QSFP) cables” on page 107
- “Removing the batteries” on page 125
- “Removing and replacing the chassis” on page 112

Removing and installing the chassis door

Attention: The chassis door must be installed to ensure the SAN768B-2 meets EMI and other regulatory certifications. Additionally, if ICL cables are not used, EMI plugs must be inserted in the ICL cable ports to meet certification standards.

Time and items required

The replacement procedure for the chassis door takes less than 5 minutes. The system can continue to run during this procedure.

Removing the chassis door

Complete the following steps to remove a chassis door.

1. Support the door to prevent it from falling.
2. Pull and remove the door. It will pop off the ball studs (Figure 27 on page 80).

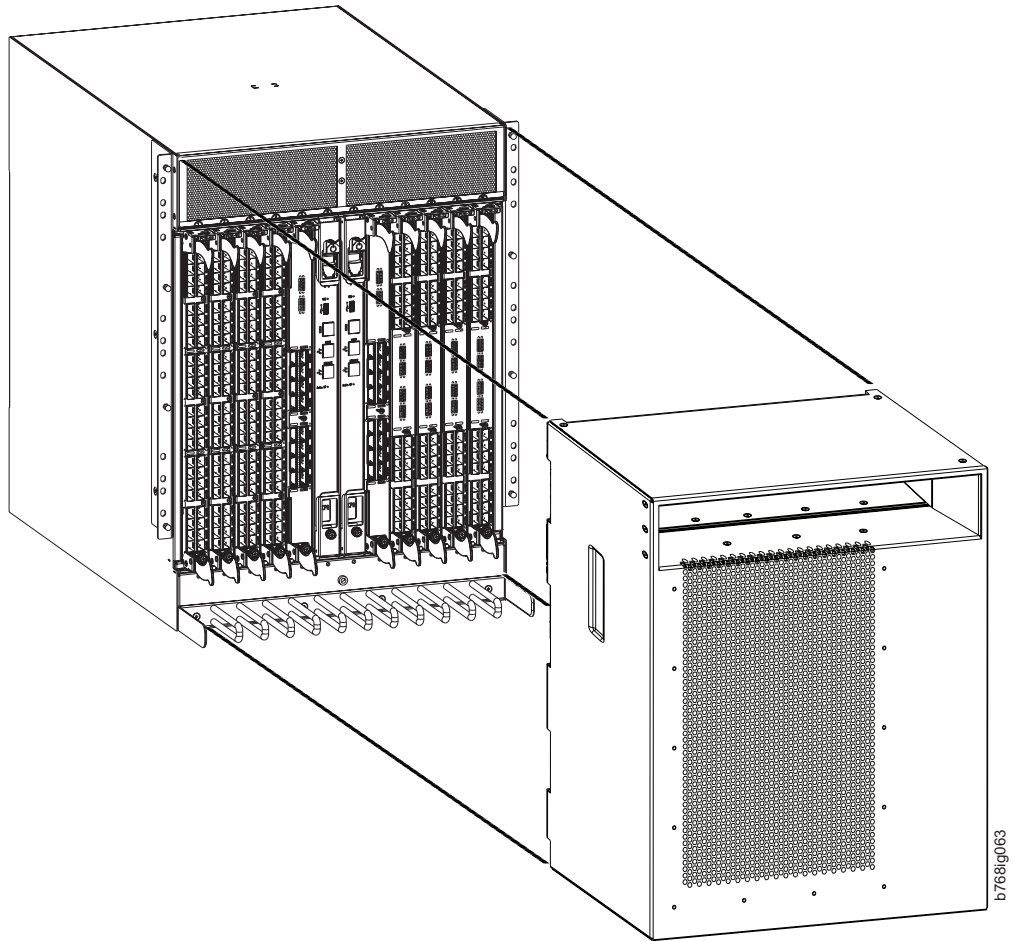

Figure 27. Chassis door

Installing the chassis door

Complete the following steps to install a chassis door.

1. Align the holes in the back side of the door with the ball studs on the chassis. See Figure 27.
2. Push the door into place. It will snap onto the studs.

Removing and installing a cable management comb

The SAN768B-2 can continue to operate during the replacement of the cable management comb.

Time and items required

The replacement procedure for the cable management comb takes less than 5 minutes. A #1 Phillips screwdriver is required.

Removing a cable management comb

Complete the following steps to remove the cable management comb.

1. Remove the chassis door (“Removing and installing the chassis door” on page 79).

2. Remove the cables from the cable management comb and rearrange the cables around the comb.
3. Unscrew and save the four screws holding the comb to the chassis (see Figure 28). Support the comb to prevent it from falling.
4. Remove the cable management comb.

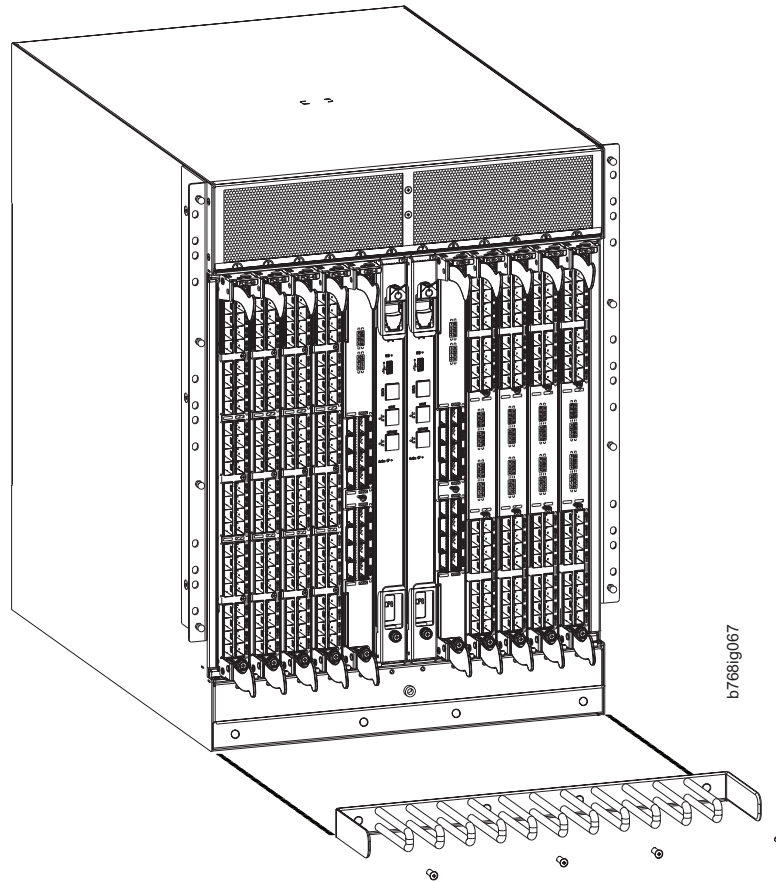

Figure 28. Cable management comb

Installing a cable management comb

Complete the following steps to install a cable management comb.

1. Align the comb with the four screw holes on the chassis.
2. Position, insert, and tighten the four screws to secure the cable management comb to the chassis.
3. Arrange the cables along the cable management comb.
4. Replace the chassis door.

Removing and installing port, application, and encryption blades

This section describes how to remove and install port, application, and encryption blades.

Attention: A filler panel should be removed only when being replaced with another blade or a filler panel. Any slot that is not occupied by a blade should be occupied by a filler panel to ensure correct cooling of the chassis and protection from dust.

Slots are numbered from 1 through 12, from left to right when facing the port side of the SAN768B-2. Port and application blades can be installed in slots 1 through 4 and 9 through 12.

Time and items required

The installation procedure for each blade takes 5 to 25 minutes, depending on the number of ports, transceivers, and cables involved. The following items are required for the blade and filler panel installation:

- ESD (electrostatic discharge) grounding strap
- Workstation computer
- Replacement blade or filler panel
- Phillips screwdriver
- Small form-factor pluggable (SFP+, or mSFP) transceivers, as needed
- Optical cables and copper cables, as needed

Removing a blade

Complete the following steps to remove a port blade.

Attention: Follow ESD precautions (see “ESD precautions” on page xix) for removal or replacement of any blade.

Note: The FC8-64 port blade, the FS8-18 encryption blade, and the FX8-24 application blade are compatible with the SAN384B, SAN384B-2, SAN768B, and SAN768B-2. The FC8-32E, FC8-48E, FC16-32, and FC16-48 port blades are compatible only with the SAN384B-2 and SAN768B-2.

Attention: If multiple blades are being replaced, replace one blade at a time.

1. Remove the chassis door (see “Removing and installing the chassis door” on page 79).
2. A failed port or application blade can be identified by inspecting the LEDs on the front panel of each blade. Check the power LED, status LED, and port status LED to identify any possible problems. See Figure 15 on page 60 to Figure 21 on page 66 for LED locations.
3. Establish a Telnet or console session.
Before installing a blade, establish a Telnet or console connection to determine a failure and verify operation after installation. Use the **switchShow** command to view the status of blades.
4. Check for adequate cable slack. Ensure there is plenty of cable slack to remove a blade without cable obstruction.
5. Ensure that the part number on the unit being installed matches the replacement part number (unless you are performing an upgrade). The **chassisShow** command displays information about the blades, including part numbers, serial numbers, and additional status.
6. Ensure that traffic is not flowing through the blade (port status LED should be off) prior to disconnecting cables.

Note: Before removing any cables from a blade, note the cable order (identify each cable by its physical port). If multiple blades are being installed, install one blade at a time. Labeling the cables before removal is recommended. It is a good practice to keep a listing of cable to port mapping. See “Cable routing tables” on page 123 for a blank sample table.

7. Disconnect all cables and transceivers from the blade. For mSFP transceivers (FC8-64 only), it is recommended that you use the pull tab to remove the transceiver from the blade before removing the cable from the transceiver.
8. Unscrew the two thumbscrews from the top and bottom ejectors on the blade (see Figure 29) using the Phillips screwdriver. Unscrew the top thumbscrew until it pops out. This initiates a hot-swap request.
9. Wait for the power LED to turn off in response to the hot-swap request before removing the blade.
10. Open the ejectors by pulling them toward the center of the blade face. Pull the blade out of the chassis using the ejectors (Figure 29).
11. If the blade is not being replaced by another blade, install a filler panel. See “Removing and installing blade filler panels” on page 84.

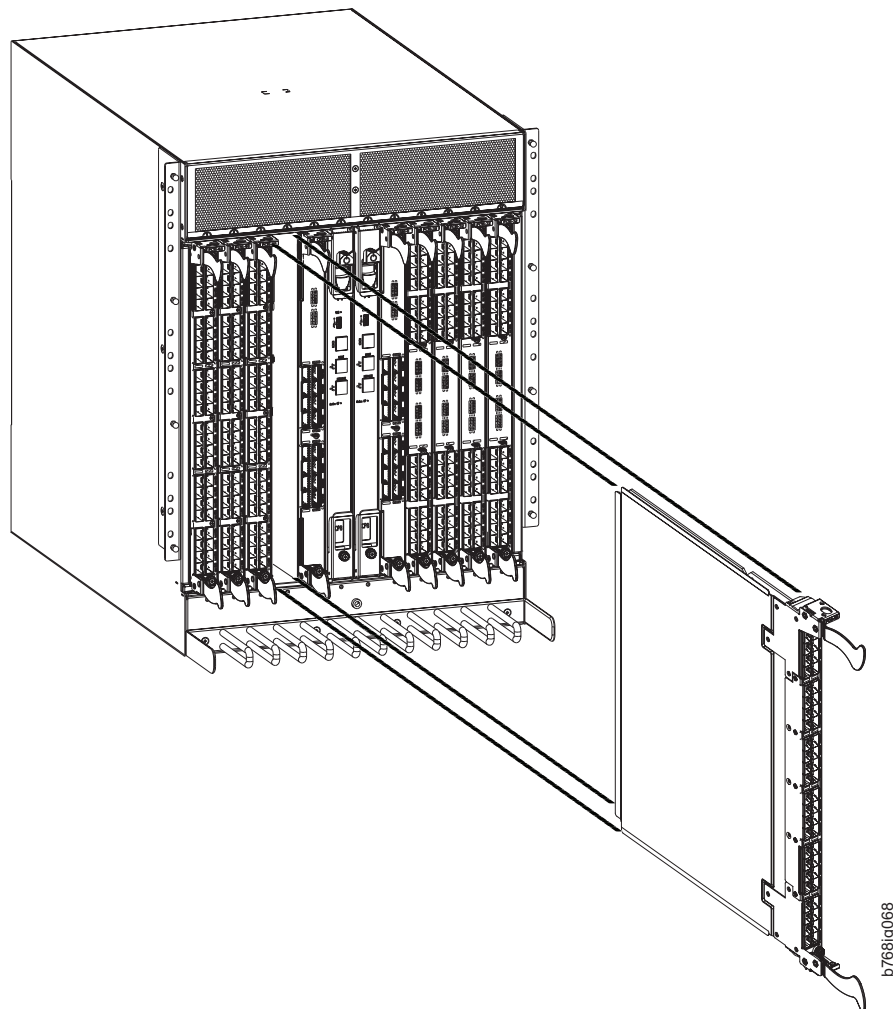

Figure 29. Port and application removal and installation (FC16-48 port blade shown as example)

Installing a blade

Complete the following steps to install a port, application, or encryption blade.

Attention: Follow ESD precautions (see “ESD precautions” on page xix).

1. Orient the blade so that the ports are at the front of the chassis and the flat side of the blade is on the left.

2. Adjust the ejectors to the open position, align the flat side of the blade inside the upper and lower rail guides in the slot, and slide the blade into the slot until it is firmly seated.
3. Adjust the ejectors to the closed position by pulling them away from the center of the blade.
4. Tighten the upper and lower thumbscrews using the Phillips screwdriver.
5. Verify that the power LED on the blade displays a steady green light (it might require a few seconds to turn on). If it does not turn on, ensure that the blade is firmly seated.
6. The Status LED on the blade will show amber until POST completes for the blade. It should then display green. If it remains amber, the board may not be properly seated in the backplane or the board may be faulty.
7. Install the transceivers and cables in the blade. For mSFP transceivers (FC8-64 port blade only), it is recommended that you install the cables in the transceivers before installing the transceivers in the blade.
8. Group and route the cables through the cable management comb.
9. Install the chassis door.

Note: The FS8-18 encryption blade requires additional configuration to enable encryption. See “Configuring for encryption (optional)” on page 48.

Removing and installing blade filler panels

This section describes how to remove and install port blade filler panels.

Note: Some filler panels have two thumbscrews and some have only one. Be sure to unscrew or tighten both if you are using the two-screw version.

Removing a filler panel

Attention: A filler panel should be removed only when being replaced with a port or application blade or new filler panel. Any slot that is not occupied by a blade should be occupied by a filler panel to ensure correct cooling of the chassis and protection from dust.

Complete the following steps to remove a filler panel.

1. Remove the chassis door.
2. Unscrew the thumb screws on the panel using a Phillips screwdriver.
3. Using the tabs, pull the filler panel out of the chassis. (See Figure 30 on page 85.)

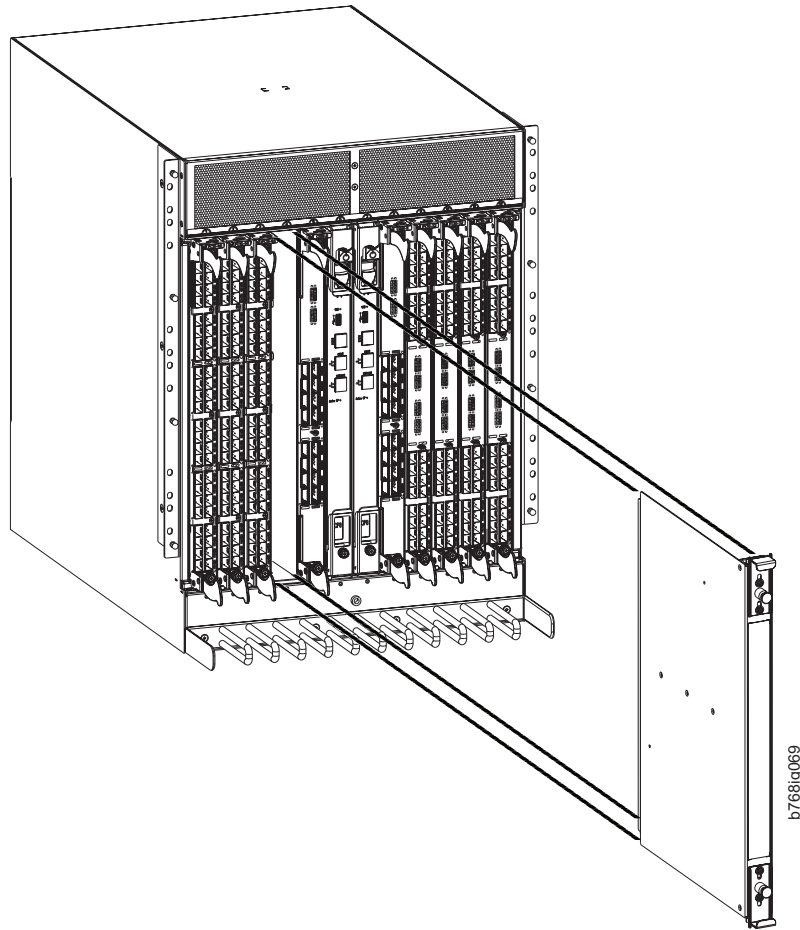

Figure 30. Filler panel removal and installation

Attention: Do not leave a slot empty. This will adversely affect cooling of the chassis. Either replace with a new filler panel or a blade.

Installing a filler panel

Complete the following steps to install a filler panel.

1. Orient the filler panel.
2. Slide the filler panel into the slot until it is firmly seated.
3. Tighten the thumb screws.
4. Install the chassis door.

Removing and installing a CP8 control processor blade

This section describes how to remove and install a control processor (CP8) blade. Each SAN768B-2 has two CP8 blades located in slot 6 and slot 7.

Attention: The firmware upgrade policy for CP8 blades specifies testing for the current Fabric OS release and one version earlier. It is possible to upgrade by more than one version, but it is a very specific and detailed process. Read the directions under “Downloading firmware from an FTP server” on page 91 or “Downloading firmware from a USB drive” on page 93 carefully.

Attention: If the new CP blade does not have the same firmware as the active CP blade, the new blade must be upgraded to the same firmware version. You can determine the firmware version on the replacement blade and do a firmware upgrade if necessary after inserting the blade in the chassis, but you **MUST** disable high availability (HA) before inserting the new blade. If the new CP blade is severely down-level, a very specific and detailed procedure must be followed to bring the blade up to the correct firmware version. Refer to the *Fabric OS Administrator's Guide* for information. Also see "Downloading firmware from an FTP server" on page 91, "Downloading firmware from a USB drive" on page 93, and "Fabric OS firmware updates" on page 50.

Time and items required

The installation procedure for the CP blade takes approximately 30 minutes. The following items are required for the CP blade installation:

- ESD (electrostatic discharge) grounding strap
- Workstation computer
- Serial cable
- IP address of an FTP server for backing up the SAN768B-2 configuration
- #2 Phillips screwdriver
- Replacement control processor (CP8) blade.

Attention: If you are upgrading through multiple versions of the Fabric OS, refer to Table 13 on page 91, to see which intermediate versions of the Fabric OS you will need. Plan carefully and provide for extra time if this is your situation.

Verifying the need for replacement

Confirm that you need to install the CP blade. The following events might indicate that a CP blade is faulty:

- The status LED on the CP blade displays steady amber, or the power LED is not lit.
- The CP blade does not respond to Telnet commands, or the serial console is not available.
- The **slotShow** command does not show that the CP blade is enabled.
- The **haShow** command indicates an error.
- The clock is inaccurate, or the CP blade does not boot up or shut down normally.
- Any of the following messages display in the error log:
 - "Slot unknown" message relating to a CP slot
 - CP blade errors or I²C timeouts
 - FRU: FRU_FAULTY messages for a CP blade
 - Configuration loader messages or "Sys PCI config" messages
 - Generic system driver messages ("FABSYS")
 - Platform system driver messages ("Platform")
 - EM messages that indicate a problem with a CP blade
 - Function fail messages for the CP master

For more information about error messages, refer to the *Fabric OS Message Reference*.

Recording critical SAN768B-2 information

Back up the SAN768B-2 configuration before you replace a CP blade. Refer to the *Fabric OS Administrator's Guide* for backup information.

1. Connect to the chassis and log in as **admin**, using a serial console connection.
2. Enter **haShow** to determine which CP blade is active:

```
SAN768B-2:admin> haShow
Local CP (Slot 7, CP1) : Active
Remote CP (Slot 6, CP0) : Standby, Healthy
HA Enabled, Heartbeat Up, HA State Synchronized
```

3. Enter all remaining commands from the serial console for the active CP blade, unless otherwise indicated. For more information about commands, refer to the *Fabric OS Command Reference*.
4. If the active CP blade is faulted, automatic failover to the standby CP blade should have occurred. Confirm that the standby CP blade is active and power off the faulted CP blade, log in to standby CP blade, and skip to step 7. If automatic failover has not occurred, manually failover the faulty blade by moving the slider to the off position (down). Then power off the faulted blade, log in to standby CP blade, and skip to step 7.
5. If both CP blades are healthy and you want to replace the standby CP blade, log in to the active CP blade and skip to step 7.
6. If both CP blades are healthy and you want to replace the active CP blade, log in to the active CP blade and run the following steps:
 - a. Run the **haFailover** command to make the standby CP blade the active blade. The currently active CP blade becomes the standby blade. Wait until the status LED on the currently active CP blade is no longer lit.
 - b. Confirm the completion of the failover by running the **haShow** command.
 - c. Log in to the new active CP blade.
7. Run the **firmwareShow** command to note the firmware version of the active CP blade.

The example below shows the results of the **firmwareShow** command when the firmware versions on the two CP blades are not the same. Note the warning message at the end of the output.

```
SAN768B-2_120:root> firmwareshow
Slot Name  Appl  Primary/Secondary Versions  Status
-----
6 CP0      FOS   v7.0.0                        STANDBY
           v7.0.0
7 CP1      FOS   v7.0.0a                       ACTIVE *
           v7.0.0a
WARNING: The local CP and remote CP have different versions
of firmware, please retry firmwaredownload command.
SAN768B-2:root>
```

8. Run **haDisable** from the active CP blade to prevent failover or communication between the CP blades during the replacement.
9. Use the **configUpload** command to upload the chassis configuration to a specified FTP server. Enter information at the prompts.
 - a. Run the **fosConfig --show** command to determine if virtual fabrics are enabled. If so, run the **configupload -vf** command. This command uploads the SAN768B-2 virtual fabric data.
 - b. If virtual fabrics are not enabled, run the **configUpload** command. This command uploads the SAN768B-2 configuration.

Removing a control processor blade (CP8)

The SAN768B-2 continues to operate while a CP blade is being installed if the redundant CP blade is active and a failover does not occur. You can prevent failover by entering the **haDisable** command.

Attention: Follow ESD precautions (see “ESD precautions” on page xix) when handling any blades.

Complete the following steps to remove a CP8 control blade (CP).

1. Remove the chassis door. (See “Removing and installing the chassis door” on page 79.)
2. Log in to the active CP as the **admin**. You can use a serial cable or Telnet, Web Tools, or Fabric Manager. Determine which CP is active using the **haShow** command or view the active LED on the front of the CP.
3. If the faulty CP is the active CP, issue the **haFailover** command. Wait until the failover has completed. Use the **haShow** command to verify the CPs are synchronized and the failover is complete.
Depending on the nature of the CP failure, it is possible that the **haFailover** command will not work. Proceed to the next step anyway.
4. Enter the **haDisable** command. This is required before physically removing and replacing a CP blade.
5. Power off the blade you are replacing by sliding the slider switch in the top ejector down, to the off position.
Do not eject the blade until the power LED is off and you have completed the next two steps.
6. Disconnect all cables from the faulty (standby) CP blade you are replacing.
7. Unscrew the thumb screws from both ejectors using the Phillips screwdriver.
8. Lever open both ejector handles simultaneously to approximately 45 degrees and pull the CP blade out of the chassis (see Figure 31 on page 89).

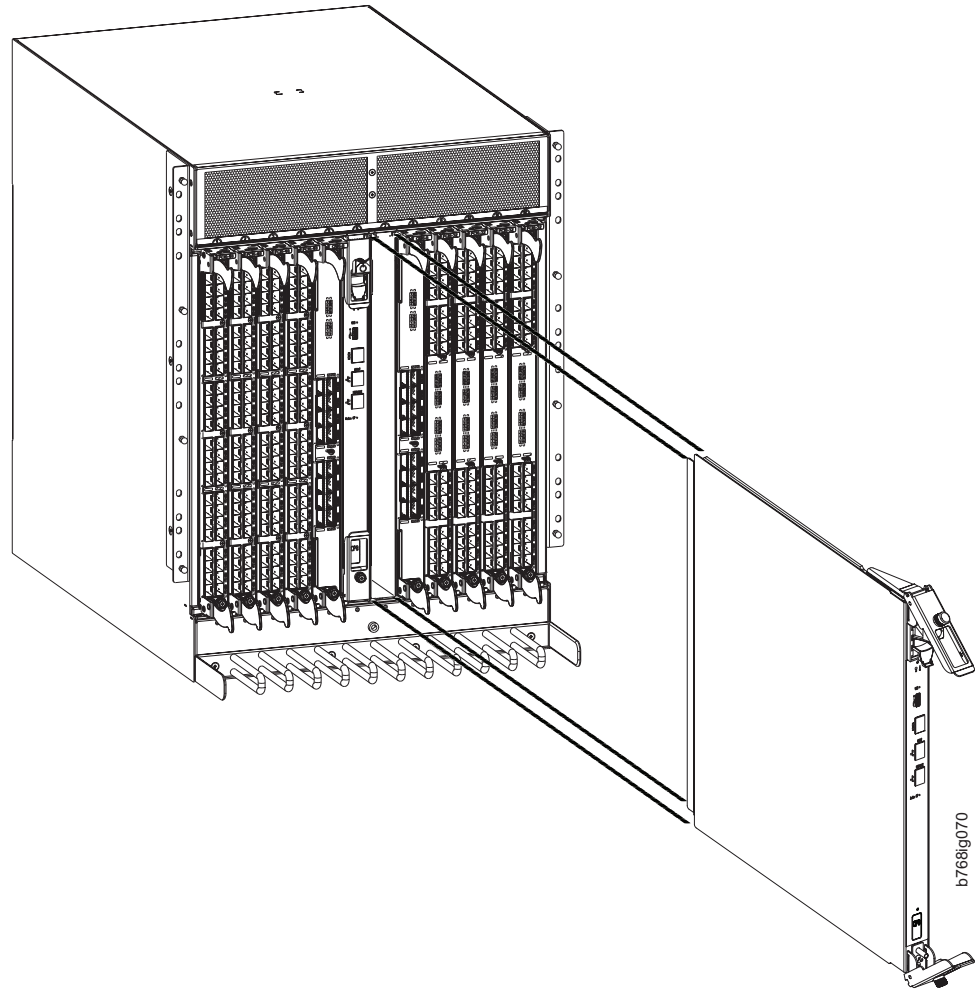

Figure 31. Removing the control processor (CP8) blade

Installing a control processor blade (CP8)

Attention: Read ALL of the instructions for replacing the CP blade before beginning the procedure. Use the same version of Fabric OS on both CP blades. Using different versions is not supported and may cause malfunctioning. If the replacement CP blade has a different version of Fabric OS, bring both blades to the same firmware version. Once you have installed the replacement CP blade, see “Verifying operation of the new CP blade” on page 90 for information about determining the version of firmware on the replacement CP blade and upgrading it if necessary.

Attention: Follow ESD precautions (see “ESD precautions” on page xix) whenever handling a blade.

Complete the following steps to install a CP blade (slot 6 or 7):

1. Open the ejector handles to approximately 45 degrees. Orient the CP blade so that the handles are toward you and the flat metal side is on your left.
2. Align the flat metal side of the CP blade inside the upper and lower blade guides in the slot. Slide the CP blade into the slot until it is firmly seated.

3. Tighten the thumb screw inside each handle using the Phillips screwdriver.
4. Turn the CP blade on by sliding the ON/OFF switch in the top handle up, to cover the thumb screw.
5. Verify that the power LED is green. If not, ensure that the CP blade has power and is firmly seated and that the ejectors are in the locked position.
6. Connect the cables to the new CP blade.
7. Remain logged in to the active CP and continue to “Verifying operation of the new CP blade.”

Verifying operation of the new CP blade

To verify that boot and POST are complete on the new CP blade and that the CP blade has achieved failover redundancy, complete the following steps.

1. Enter **slotShow**. The command output shows the new CP blade as “enabled.” If the standby CP is unresponsive, try unplugging the new CP blade, running **haDisable** on the active CP blade, and plugging the new CP blade back in. At that point, you can repeat step 1 to begin the verification process again.
2. Determine the Fabric OS version by entering **firmwareShow**. If the serial console on the replacement CP blade is connected, issue the **firmwareShow** command there. More information is available through the console.

Attention: The SAN768B-2 requires Fabric OS 7.0.0 or later to be recognized. The FC8-32E and FC8-48E blades require FOS 7.0.1 or later. If the firmware on the replacement blade is earlier than 7.0.0, it must be brought up to the version (7.0.0 or later) on the active CP blade, which must be at least 7.0.0. IBM recommends upgrading to the latest version available.

3. If the firmware versions for both CP blades are the same, skip to “Completing the CP8 blade replacement” on page 95. If the firmware version on the replacement blade does not match that on the active CP blade, a warning message appears with the results of the **firmwareShow** command. The results of the **firmwareShow** command may look similar to the following example. Note the warning message at the end of the output.

```
SAN768B-2_120:admin> firmwareshow
Slot Name  Appl  Primary/Secondary Versions  Status
-----
6 CP0      FOS   v7.0.0a                      ACTIVE
           v7.0.0a
7 CP1      FOS   v7.0.0                        STANDBY *
           v7.0.0
```

* Local CP

WARNING: The local CP and remote CP have different versions of firmware, please retry firmwaredownload command.

4. You must bring the replacement blade to the same firmware level as the active blade by using the **firmwareDownload -s** command *directly on the replacement blade* to bring it up to the proper level. The **firmwareShow** command results show which slots hold the active and standby (replacement) CP blades. If you are using an FTP server to download the firmware, skip to “Downloading firmware from an FTP server” on page 91. If you are using a USB device to download the firmware, skip to “Downloading firmware from a USB drive” on page 93. If the firmware on the standby CP blade is more than one level down from the level on the active CP blade, you must have formatted USB devices for each of the versions you will need to upgrade.

Table 13. Steps for upgrading through multiple versions of Fabric OS

If your current Fabric OS version is...	and your target FOS version is...	complete these upgrade steps
7.0.0	7.0.1	use firmwareDownload -s to upgrade directly to 7.0.1

Downloading firmware from an FTP server

For this task, refer to Table 13 for the correct sequence of upgrading firmware versions to reach your target version. Complete the following steps to download the firmware from an FTP server.

1. Log in to the standby CP blade as **admin**. If you need to know the IP address of the standby blade, run **ipAddrShow**.
You should also remain logged in to the active CP blade in order to monitor it.
2. Run **firmwareDownload -s** to download the firmware to the standby CP blade. The **-s** option also disables the autoreboot, so you will have to manually issue a reboot after the download finishes to initiate **firmwarecommit**. Enter all requested information (use default values).
The following example shows the results of running **firmwareDownload -s** for Fabric OS version 7.0.0a.

```
SAN768B-2_124:admin> firmwaredownload -s v7.0.0a
Server IP: 10.31.2.25, Protocol IPv4
Checking system settings for firmwaredownload...
System settings check passed.
```

```
You are running firmwaredownload with auto-reboot disabled.
After firmware is downloaded, please reboot the system to
activate the new firmware.
Firmware is being downloaded to the switch. This step may take
up to 30 minutes.
Preparing for firmwaredownload...
2011/05/24-10:59:39, [SULB-1001], 7258, SLOT 7 | CHASSIS,
WARNING, SAN768B-2, Firmwaredownload command has started.
2011/05/24-10:59:39, [SULB-1036], 7259, SLOT 7 | CHASSIS, INFO,
SAN768B-2, The current Version: Fabric OS v7.0.0
```

```
Start to install packages...
dir #####
ldconfig #####
<some output removed>
fsl8548-brcdecc-module #####
eccrepd #####
hss-diag #####
```

```
Manufacturing key is Pushed to Active EE 0
Removing unneeded files, please wait ...
Finished removing unneeded files.
All packages have been downloaded successfully.
Relocating an internal firmware image on the CP blade.
2011/05/24-11:07:22, [SULB-1032], 7260, SLOT 7 | CHASSIS, WARNING,
SAN768B-2, Relocating an internal firmware image on the CP.
net boot...
The internal firmware image is relocated successfully.
2011/05/24-11:09:26, [SULB-1039], 7261, SLOT 7 | CHASSIS, INFO,
SAN768B-2, CP has completed relocating the internal firmware image.
Firmware has been downloaded to the secondary partition of the switch.
2011/05/24-11:09:27, [SULB-1044], 7262, SLOT 7 | CHASSIS, INFO,
```

```
SAN768B-2,  
Firmwaredownload to secondary partition has completed  
successfully.  
SAN768B-2:admin>
```

3. To download firmware through the IBM site,
 - a. Go to the IBM Support Portal, www.ibm.com/supportportal
 - b. Search for your product machine type (2499) or product name
 - c. On the displayed page click **Download** in the **Task** section
 - d. From the displayed page, select the appropriate release notes link and read the release notes prior to downloading and installing the firmware update
 - e. From the **Release notes** page, click the **Release Firmware** link and follow the online prompts to navigate to the **Brocade Downloads for IBM End Users** page.
 - f. Follow the instructions on the Brocade pages. Enter all requested information (use default values).
4. When the download process finishes, run **firmwareDownloadStatus** to verify that the firmware has been updated. The command displays a running account of the progress of the **firmwareDownload** command (if it is still running) until the command has completed. The final message is similar to the following and will appear with a date and time stamp:

```
Slot 6 (CP0, active): Firmwaredownload command has completed successfully. Use  
firmwaredownload show to verify the firmware versions.
```
5. On the standby CP blade (the blade for which you just changed the firmware level), run **reboot**. The reboot of the standby CP will initiate a **firmwarecommit** to the secondary partition and log you out.

```
SAN768B-2:admin> reboot  
Broadcast message from root (ttyS0) Fri Jun 18 14:49:45 2011...  
The system is going down for reboot NOW !!  
INIT: Switching to runlevel: 6  
INIT: Sending processes the TERM signal  
SAN768B-2:admin> HAMu  
Heartbeat down, stop FSS  
Unmounting all f##exiting due to signal: 9, pending signals:  
0x20000, 0x0 filesystems.  
Please stand by while rebooting the system...  
Restarting system.  
The system is coming up, please wait...  
.  
.  
.  
Fri Jun 18 14:53:13 2011: Doing firmwarecommit now.  
Please wait ...  
Fri Jun 18 14:55:27 2011: Firmware commit completes successfully.  
Validating the filesystem ...  
Fri Jun 18 22:36:05 2011: Doing firmwarecommit now.  
Please wait ...  
Fri Jun 18 22:36:48 2011: Firmware commit completes successfully.  
2011/06/18-14:56:50, [SULB-1004], 908, SLOT 7 | CHASSIS, INFO,  
SAN768B-2, Firmwarecommit has completed.  
2011/06/18-14:56:50, [SULB-1036], 909, SLOT 7 | CHASSIS, INFO,  
SAN768B-2, The new Version: Fabric OS v7.0.0a  
2011/06/18-14:56:50, [SULB-1002], 910, SLOT 7 | CHASSIS, INFO,  
SAN768B-2, Firmwaredownload command has completed successfully.
```

Note: The time stamp on the co-cpu may not be in sync with the main cpu on the blade. This is not a cause for concern.

6. Log back in to the standby CP blade and run **firmwareDownloadStatus** on the standby CP blade to validate a successful commit. This may take up to 10 minutes.
7. If you are upgrading through several levels of the Fabric OS, repeat step 2 through step 6 as often as necessary to complete the upgrade. Otherwise, proceed to step 8.
8. Log out of the standby CP blade and log in to the active CP blade.
9. Proceed to “Completing the CP8 blade replacement” on page 95

Downloading firmware from a USB drive

For this task, refer to Table 13 on page 91 for the correct sequence of upgrading firmware versions to reach your target version.

Complete the following steps to download the firmware from a USB device.

This section assumes that the new firmware has already been copied onto the USB device. The folder structure on the USB device must be as follows in order to allow the device to be enabled:

```
brocade>
config
firmware
firmwareKey
support
```

The firmware folder contains the folder for the specific release you are installing.

1. Insert the USB drive into the USB port of the active CP blade.
2. Attach a serial cable from the PC to the active CP blade.
3. Log in to the active CP blade AS **admin** if you are not still logged in and enter **usbStorage -e** to enable the USB device.
4. Remove the serial cable from the active CP blade and attach it to the standby CP blade and log in as **admin**.
5. Run **firmwareDownload -s -U vX.X.X** (where X.X.X is the firmware version you are downloading) to download the firmware to the standby CP blade. The **-s** option also disables the autoreboot, so you will have to manually issue a reboot after the download finishes to initiate **firmwarecommit**. Enter all requested information (use default values).

The following example shows the results of running **firmwaredownload** for Fabric OS version 7.0.0a.

```
SAN768B-2_124:admin> firmwaredownload -sU v7.0.0a
Server IP: 10.31.2.25, Protocol IPv4
Checking system settings for firmwaredownload...
System settings check passed.
You are running firmwaredownload with auto-reboot disabled.
After firmware is downloaded, please reboot the system to
activate the new firmware.
Firmware is being downloaded to the switch. This step may take up to 30
minutes.
Preparing for firmwaredownload...
2011/05/24-10:59:39, [SULB-1001], 7258, SLOT 7 | CHASSIS, WARNING,
SAN768B-2, Firmwaredownload command has started.
2011/05/24-10:59:39, [SULB-1036], 7259, SLOT 7 | CHASSIS, INFO,
SAN768B-2,
The current Version: Fabric OS v7.0.0
Start to install packages...
dir #####
ldconfig #####
```

<some output removed>

```

fs18548-brcdecc-module #####
eccrepd #####
hss-diag #####
Manufacturing key is Pushed to Active EE 0
Removing unneeded files, please wait ...
Finished removing unneeded files.
All packages have been downloaded successfully.
Relocating an internal firmware image on the CP blade.
2011/05/24-11:07:22, [SULB-1032], 7260, SLOT 7 | CHASSIS, WARNING,
SAN768B-2, Relocating an internal firmware image on the CP.
net boot...
The internal firmware image is relocated successfully.
2011/05/24-11:09:26, [SULB-1039], 7261, SLOT 7 | CHASSIS, INFO,
SAN768B-2, CP has completed relocating the internal firmware image.
Firmware has been downloaded to the secondary partition of the switch.
2011/05/24-11:09:27, [SULB-1044], 7262, SLOT 7 | CHASSIS, INFO, SAN768B-2,
Firmwaredownload to secondary partition has completed successfully.
SAN768B-2_124:admin>

```

6. When the download process finishes, run **firmwareDownloadStatus** to verify that the firmware has been updated. The command displays a running account of the progress of the **firmwareDownload** command until the command has completed. The final message is similar to the following example and will appear with a date and time stamp:

```

Slot 6 (CP0, active): Firmwaredownload command has completed
successfully. Use firmwareshow to verify the firmware versions.

```

7. Ensure that you are still logged in to the standby CP blade (the blade for which you just changed the firmware level) and type **reboot**. The reboot of the standby CP will initiate a **firmwarecommit** to the secondary partition and log you out.

```

SAN768B-2_124:admin> reboot
Broadcast message from root (ttyS0) Fri Jun 18 14:49:45 2011...
The system is going down for reboot NOW !!
INIT: Switching to runlevel: 6
INIT: Sending processes the TERM signal
SAN768B-2_124:admin> HAMu
Heartbeat down,stop FSS
Unmounting all f##exiting due to signal: 9, pending signals:
0x20000, 0x0 filesystems.
Please stand by while rebooting the system...
Restarting system.
The system is coming up, please wait...
.
.
.
Fri Jun 18 14:53:13 2011: Doing firmwarecommit now.
Please wait ...
Fri Jun 18 14:55:27 2011: Firmware commit completes successfully.
Validating the filesystem ...
Fri Jun 18 22:36:05 2011: Doing firmwarecommit now.
Please wait ...
Fri Jun 18 22:36:48 2011: Firmware commit completes successfully.
2011/06/18-14:56:50, [SULB-1004], 908, SLOT 7 | CHASSIS, INFO,
SAN768B-2, Firmwarecommit has completed.
2011/06/18-14:56:50, [SULB-1036], 909, SLOT 7 | CHASSIS, INFO,
SAN768B-2, The new Version: Fabric OS v7.0.0a
2011/06/18-14:56:50, [SULB-1002], 910, SLOT 7 | CHASSIS, INFO,
SAN768B-2,Firmwaredownload command has completed successfully.

```

Note: The time stamp on the co-cpu may not be in sync with the main cpu on the blade. This is not a cause for concern.

8. Log back in to the standby CP blade and enter **firmwareDownloadStatus** on the standby CP blade to validate a successful commit. This may take up to 10 minutes.
9. If you are upgrading through several levels of the Fabric OS, repeat step 5 through step 8 as often as necessary to complete the upgrade. Otherwise, proceed to step 10
10. Log out of the standby CP blade and log in to the active CP blade.
11. Proceed to “Completing the CP8 blade replacement.”

Completing the CP8 blade replacement

Complete the following steps to complete the CP8 control blade replacement procedure.

1. Enter **haEnable** to re-enable HA on the active CP blade

Note: **haEnable** will cause the standby CP blade to reboot. Wait until the power cycles and the POST completes before moving to the next step. POST is complete when the Status LED on the CP blade returns to a steady green state.

2. Enter **haShow** and verify that the command output includes “*HA Enabled, Heartbeat Up*”. If it is not yet enabled, re-enter the command until you have verified that redundancy is achieved.

```
SAN768B-2_124:admin> hashow
Local CP (Slot 7, CP1) : Active
Remote CP (Slot 6, CP0) : Standby, Healthy
HA Enabled, Heartbeat Up, HA State Synchronized
```

3. Enter **firmwareShow** to verify that the firmware version has been updated and that the versions are the same on the two CP blades. Not all slot numbers are shown in this example.

```
SAN768B-2_a:admin> firmwareshow
Slot Name      Appl  Primary/Secondary Versions  Status
-----
4 FX8-24      FOS   v7.0.0a
              v7.0.0a
6 CP0         FOS   v7.0.0a                STANDBY
              v7.0.0a
7 CP1         FOS   v7.0.0a                ACTIVE *
              v7.0.0a
10 FX8-24     FOS   v7.0.0a
              v7.0.0a
```

If you have one or more application blades in the chassis, the Fabric OS automatically detects mismatches between the active CP firmware and the application blade's firmware and triggers the auto-leveling process. This auto-leveling process automatically updates the application blade firmware to match the active CP. At the end of the auto-leveling process, the active CP and the application blades will run the same version of the firmware.

4. Pack the faulty CP blade in the packaging provided with the new CP blade for return to IBM, following local procedures.
5. Install the chassis door (See “Removing and installing the chassis door” on page 79.)

Removing and installing a core switch blade (CR16-8)

This section describes how to remove and install a core switch blade. Each SAN768B-2 has two core switch blades: one in slot 5 and one in slot 8. See Figure 32 on page 97.

Time and items required

The installation procedure for the core switch blade takes approximately 30 minutes. The following items are required for the core switch blade installation:

- ESD grounding strap
- Phillips #2 screwdriver
- Replacement core switch blade (CR16-8).

Verifying the necessity of installation

Confirm that you need to replace the core switch blade before continuing. The following events might indicate that a core switch blade is faulty:

- The status LED on the core switch blade is lit amber, or the power LED is not lit.
- The **slotShow** command does not show that the core switch blade is enabled.
- The **haShow** command indicates an error.
- Any of the following messages display in the error log:
 - “Slot unknown” message relating to a core switch blade slot
 - core switch blade errors or I²C timeouts
 - FRU: FRU_FAULTY messages for a core switch blade
 - Configuration loader messages or “Sys PCI config” messages
 - Generic system driver messages (“FABSYS”)
 - Platform system driver messages (“Platform”)
 - Error messages that indicate a problem with a core switch blade
 - Function fail messages for the core switch blade master

For more information about error messages, refer to the *Fabric OS Message Reference*.

Removing a core switch blade (CR16-8)

The SAN768B-2 continues to operate while a core switch blade is being replaced.

Attention: Follow ESD precautions (“ESD precautions” on page xix).

Note: The CR16-8 blade is compatible only with the SAN768B-2

Complete the following steps to remove a CR blade.

1. Remove the chassis door (see “Removing and installing the chassis door” on page 79).
2. Unscrew the two thumb screws from the ejectors on the blade using the Phillips screwdriver. Unscrew the top thumb screw until it pops out. This initiates a hot-swap request.
3. Label and then disconnect cables from the faulty core switch blade.
4. Open the ejectors by rotating them toward the center of the blade face. Pull the blade out of the chassis using the ejectors. (see Figure 32 on page 97).

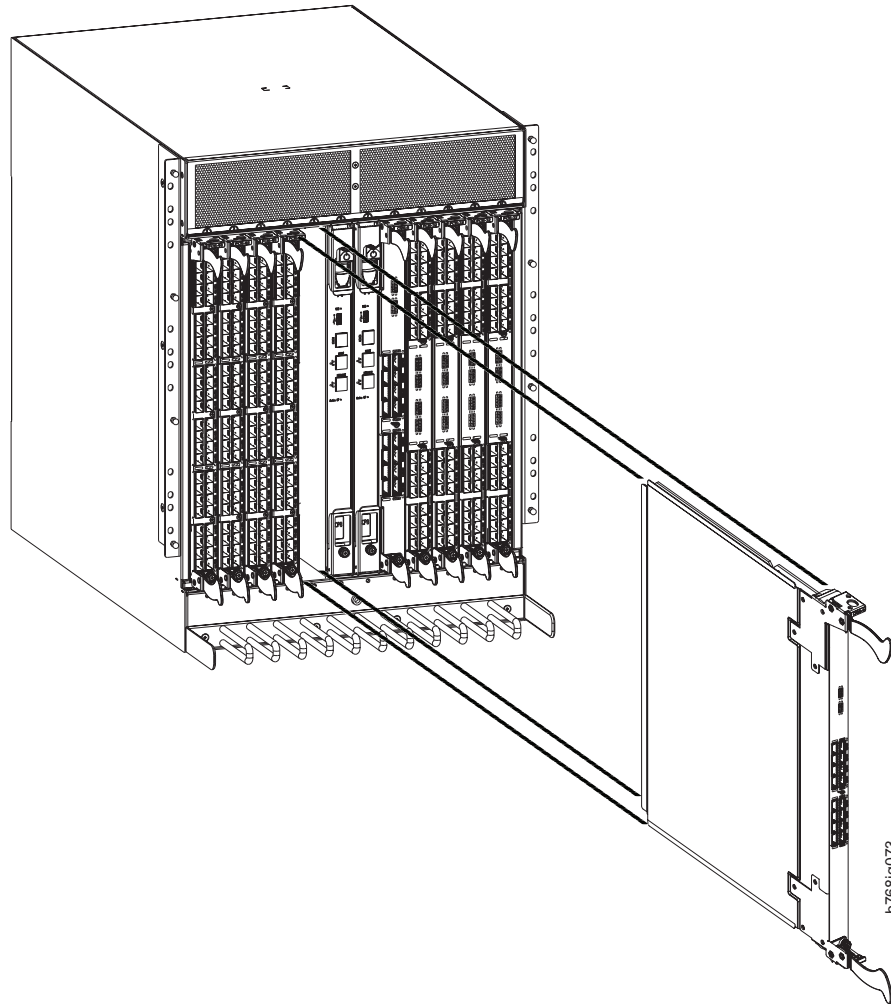

Figure 32. Removing the core switch blade

Installing a core switch blade (CR16-8)

Attention: Follow ESD precautions (“ESD precautions” on page xix).

Note: The CR16-8 blade is compatible only with the SAN768B-2.

Complete the following steps to install a CR16-8 core switch blade.

1. Open the ejectors by rotating them toward the center of the blade face. Orient the CR blade so that the handles are toward you and the flat metal side is on your left.
2. Align the flat side of the core switch blade inside the lower and upper blade guides in the slot. Slide the core switch blade into the slot until it is firmly seated.
3. Close the ejectors by rotating them away from the center of the blade. The levering action of the ejectors seats the blade in the slot.
4. Power on the blade by screwing in the thumbscrews.

5. Verify that the power LED is green (this might require a few seconds). If not, ensure that the core switch blade has power and is firmly seated and that the ejectors are in the locked position.
6. The status LED on the new blade is initially amber and will be until POST for the blade completes. This may take as long as several minutes. It will then turn green.
7. Connect the cables to the new core switch blade. If the QSFP cables are not used, make sure the plugs are in the QSFP transceivers.
8. Install the chassis door. (See “Removing and installing the chassis door” on page 79.)
9. Pack the faulty core switch blade in the packaging provided with the new core switch blade for return to IBM, following local procedures.

Removing and installing a power supply

Use this procedure to remove and install a power supply.

Attention: Depending on the blade configuration of the chassis and the number of power supplies installed, the SAN768B-2 may be able to continue operating during the replacement. See “Power specifications” on page 145 to determine your power requirements. If insufficient power is present, the chassis will start powering down blades until the power demand can be met.

Figure 33 shows the location and identification of the power supplies.

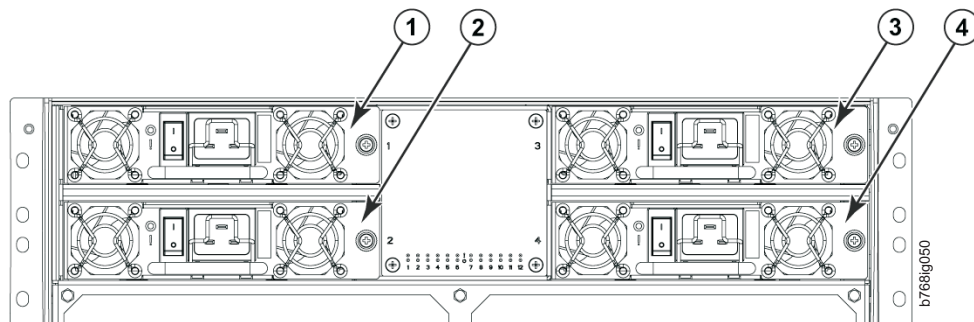

Figure 33. Power supply locations

- | | | | |
|----------|----------------------|----------|----------------------|
| 1 | Power supply 1 (PS1) | 3 | Power supply 3 (PS3) |
| 2 | Power supply 2 (PS2) | 4 | Power supply 4 (PS4) |

Time and items required

The installation procedure for each power supply takes less than 5 minutes. A power supply unit or filler panel is required for the power supply installation.

Removing a power supply

Complete the following steps to remove a power supply.

1. If the SAN768B-2 will not be operating during the replacement procedure, go to step 2.

If the SAN768B-2 will continue operating during the replacement, check the power LEDs to verify that the minimum number of power supplies is functioning. See “Power specifications” on page 145 to determine your power requirements.

2. Turn off the power switch.
3. Remove the power cord.
4. Loosen the thumbscrew.
5. Grasp the handle and pull, sliding the power supply from the chassis, supporting the power supply from beneath as you remove it. (see Figure 34).
6. If you are not replacing the power supply, insert a filler panel into the slot.

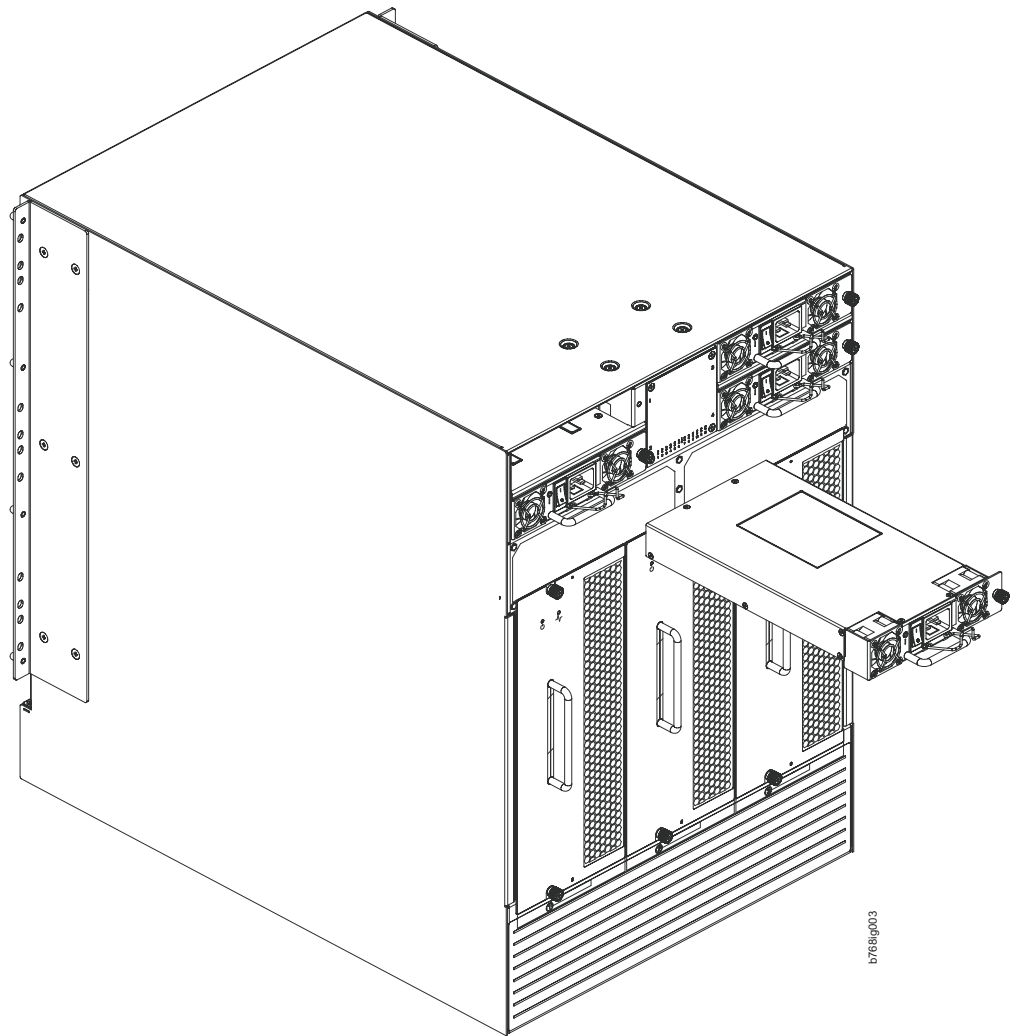

Figure 34. Removing and installing a power supply

Installing a power supply

Complete these steps to install a power supply.

1. Remove any filler panels.
2. Insert the power supply into the slot. Verify that the power supply is seated by gently pulling on the handle. The power supply should resist movement as you pull.

3. Tighten the thumbscrew.
4. Replace the power cord.
5. Turn on the power switch.
6. Verify that the power LED on the power supply displays a steady green light.

Removing and installing a blower assembly

Use this procedure for removing and installing a blower assembly.

Attention: The SAN768B-2 can continue operating during the replacement of one blower assembly if the other two blower assemblies are operating. To ensure continuous adequate cooling, maintain all three operating blower assemblies at all times except for the brief period when replacing a blower assembly.

Time and items required

The installation procedure for each blower assembly takes less than 5 minutes. The following items are required for the blower assembly installation:

- Replacement blower assembly
- Phillips #2 screwdriver

Removing a blower assembly

Complete these steps to remove a blower assembly.

1. Before removing a blower assembly, verify that the other blower assemblies are functioning correctly. The power LEDs should be steady green.
2. Use the Phillips screwdriver to loosen the captive screws at the top and bottom of blower assembly (see Figure 35 on page 101).
3. Grasp the handle and pull, sliding the blower assembly from the chassis and supporting the blower assembly from beneath as you remove it.

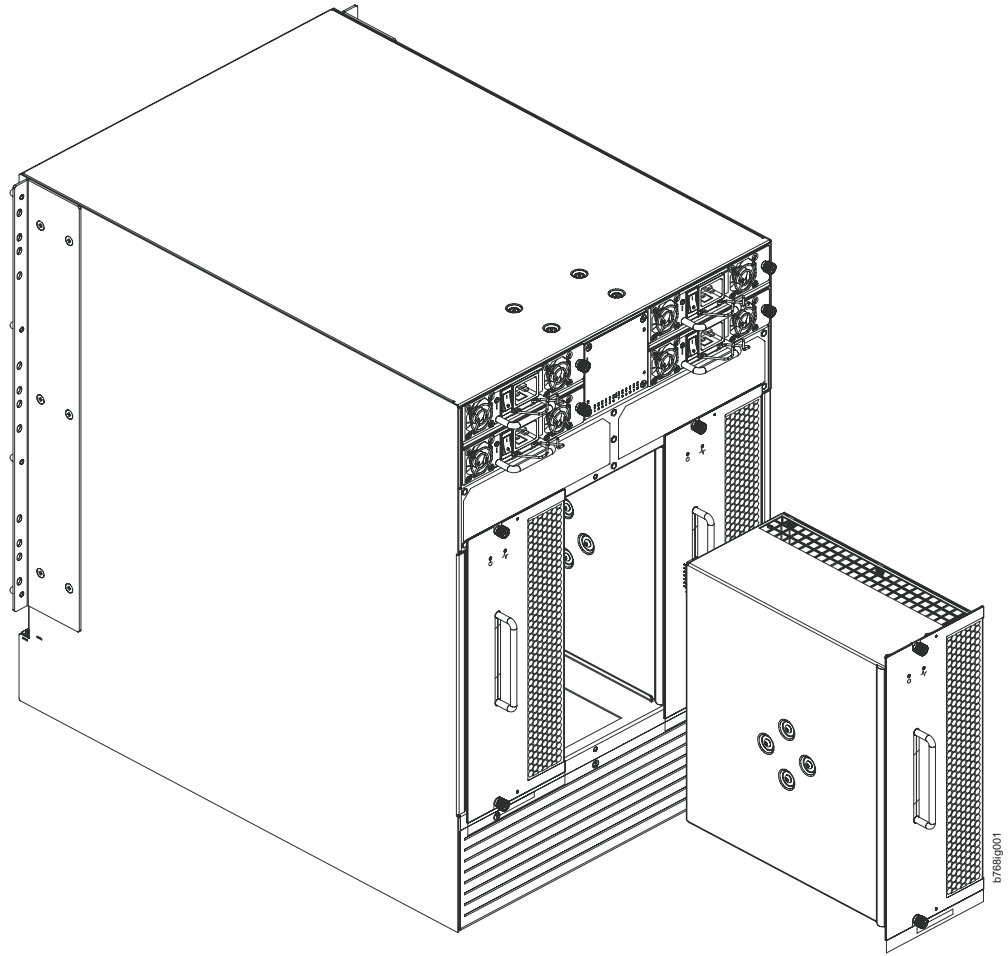

Figure 35. Removal and replacement of the blower assembly

Installing a blower assembly

Complete these steps to install a blower assembly.

1. Orient the blower assembly and slide it into the chassis, pushing firmly to ensure that it is seated.
2. Verify that the power LED displays a green light.
3. Use the screwdriver or your fingers to tighten the captive screws.

Removing and installing a WWN bezel and WWN card

Note: The World Wide Name (WWN) cards contain fully redundant circuits and normally do not require installation. Two WWN cards are located beneath the WWN bezel.

Time and items required

Allow approximately 20 minutes to replace a WWN card. The following items are needed to install a WWN card:

- ESD grounding strap
- #2 Phillips screwdriver (required only for some versions of the WWN card)

- If a serial console session is used: serial cable and a workstation computer with a terminal emulator application (such as HyperTerminal for Windows systems or TIP for Solaris systems)

Verifying the need for replacement

Before replacing a WWN card, verify that the replacement is necessary.

Any of the following events can indicate that the card requires replacement:

- Status LEDs on the WWN bezel do not reflect the actual status of the components
- Power or status LEDs on WWN card indicate a problem
- Problems viewing or modifying the data stored on the WWN card
- Error messages regarding WWN units #1 or #2

See “WWN bezel and WWN card status” on page 75 for details on checking the status of the WWN cards. System messages and LED patterns are described in that section.

Removing the WWN bezel and WWN card

Complete these steps to remove the WWN bezel and WWN card.

Attention: Follow ESD precautions (see “ESD precautions” on page xix).

1. Open a Telnet session to the SAN768B-2 and log in to the active CP as **admin**. The default password is **password**.
2. Verify that you are logged into the active CP. Run the **haShow** command to determine the active CP.
3. Run the **supportSave** command on the active CP to capture all settings. If any problems occur during the replacement, the information will be important for solving the problem
4. Enter **fruReplace wwn** from the active CP blade and wait for the phrase, "Do you wish to continue [y/n]?" to display; then enter **y**.
5. Wait until the WWN card data is backed up. **Do not** enter **continue** until the mechanical replacement is complete (see “Installing the WWN bezel and WWN card” on page 103).

```
switch:admin> frureplace wwn
This is the WWN card hot swap interface.
Continuing from this point will require
the whole process to be completed.
If this process is not complete due to a
power cycle, or CP failover, please follow
the recovery procedure in
Core Switch WWN Card
Replacement Procedure (for appropriate chassis)
Do you wish to continue [y/n]?
```

Backing up WWN card data, please wait about 25 seconds for further instruction.
Please install the new FRU now.

If this session lost for any reason, please re-enter the frureplace command and follow the instructions to complete the operation.

Please enter the word `continue' after the new WWN card has been installed:

6. Wait until all the LEDs on the WWN bezel turn off.

7. Remove the screws from the WWN bezel (see Figure 36). Pull the bezel away from chassis and set it aside. The WWN cards are visible.
8. Use a Phillips screwdriver to unscrew the two screws which secure the WWN card to the chassis. Hold the card by the edges and remove it.
9. Disconnect the WWN cable by depressing the cable connector latch and pulling the connector from the WWN module.
10. Set the WWN card on a static-free surface, such as a grounding pad.

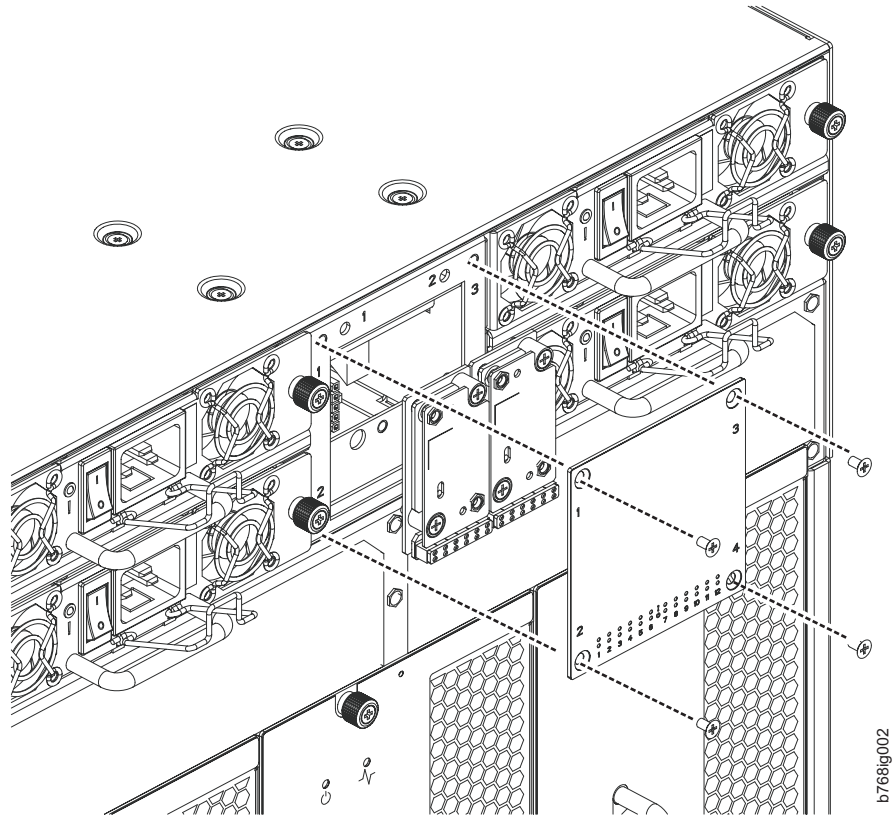

Figure 36. WWN bezel and card removal and installation

Installing the WWN bezel and WWN card

Complete the following steps to install the WWN bezel and WWN card.

Attention: Follow ESD precautions.

1. Unpack the new WWN card and save the packaging for the faulty WWN card.
2. Hold the card by the edges and insert the WWN cable onto the WWN module until it is fully seated. Use the Phillips screwdriver and the two screws to attach the WWN card to the chassis.

Note: If a serial console session is active, several “removal detected” and “insertion detected” messages display on the console because of the installation.

3. In the CLI session, enter **continue** to indicate that the replacement has been completed.

Please enter the word `continue' after the new WWN card has been installed: **continue**

Restoring the information to the replacement FRU now, please
wait about 20 seconds to complete
Verifying the replacement FRU now...
WWN card hot swap is now complete.
FRU replacement completed successfully!

4. If the command fails for any reason, do not reboot or power off the system. Repeat the **fruReplace wwn** command which will attempt to recover the WWN card.
5. Verify that the WWN card is correctly connected by checking the LEDs on the WWN card to see if they reflect the status of the components.

Note: The LEDs might take up to 2 minutes after WWN card installation to begin functioning.

6. Install the WWN bezel. Orient the bezel on the chassis (see Figure 36 on page 103). Insert and tighten the screws.
7. Pack the faulty WWN card in the packaging provided with the new card for return to IBM, following local procedures.

Removing and installing transceivers

Attention: Use only transceivers that are supported for this product. Only transceivers purchased from IBM are supported. The use of transceivers that are not supported may cause data loss or cause the product to malfunction. For a listing of transceivers compatible with this product:

- Go to the IBM Support Portal www.ibm.com/supportportal.
- In the **Search** field, enter **b-type supported transceiver**.
- Alternatively, use this direct link: <http://www-01.ibm.com/support/docview.wss?uid=ssg1S1004421>.

Note: The 16 Gbps-capable SFP+s auto-negotiate at 4, 8, and 16 Gbps. The single-speed 10 Gbps SFP+s can also be used in the 16 Gbps port blades. The 8 Gbps-capable mSFPs and SFP+s auto-negotiate at 2, 4, and 8 Gbps. The mSFPs are compatible only with the FC8-64 high density port blade. The 16 Gbps SFP+s should be used only with the FC16-32 and FC16-48 port blades.

Attention: With increasing speeds of optical connections, the cleanliness of the connections assumes greater importance in ensuring maximum performance and error free transmission. Due to the tighter tolerances associated with state of the art optics, levels of contamination that were acceptable at lower speeds may not be at higher speeds. While IEC Standard 61300-3-35 specifies a set of guidelines for trouble free performance, most issues can be avoided by adhering to the following best practices:

- When cables or connectors are not in use for extended periods of time, use the dust covers provided.
- Ensure that the cable length and type that is used are suitable for the speed and application.
- Inspect and clean optical connections and fiber cables before you connect or reconnect components.
- Ensure that cables are properly seated within the connector.

Kits are commercially available for cleaning and inspecting these connections. IBM also offers services that will ensure optimal condition of the network.

Time required

The replacement procedure for a transceiver takes less than five minutes

Items required

- Replacement mSFP or SFP+
- Optical transceiver extraction tool (for SFP+ transceivers)

Removing and installing an SFP+ optical transceiver

The SAN768B-2 comes with a transceiver extraction tool (see Figure 37) and holster. The extraction tool is designed to remove transceivers with wire bails from blades where the space is limited.



Figure 37. Optical transceiver (SFP+) extraction tool

Note: This tool is part of the SAN768B-2 ship group and should be kept with the chassis.

Attention: mSFP optical transceivers should not be inserted into ports intended for SFP+ transceivers. They will be faulted on power-up.

Removing an SFP+ optical transceiver

Complete the following steps to remove an SFP+ transceiver.

Note: The 16 Gbps SFP+ transceivers have an attached pull tab like the mSFPs. Instead of using the extraction tool, simply grasp the pull tab and pull it straight out to remove the 16 Gbps SFP+ and the connected cable from the port (Figure 38). Detach the cable from the 16 Gbps SFP+ once you have disconnected the unit from the port. See the mSFP transceiver in Figure 40 on page 107 for the basic appearance of the 16 Gbps transceiver.

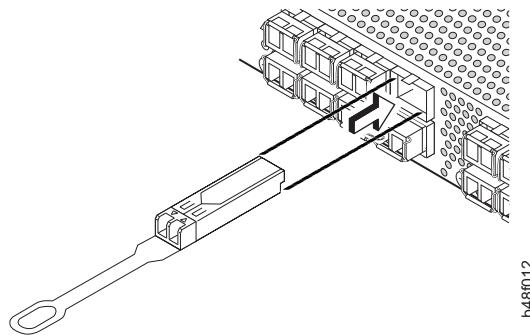

Figure 38. Installing and removing a 16 Gbps SFP+ with pull tab (shown without cable attached)

Complete the following steps to remove an SFP+ with an attached wire bail.

1. Remove any cables that are inserted into the transceiver. Use the extraction tool to open the cable latching mechanism.
2. Using the hooked end of the tool, pull the bail (wire handle) **1** away from its pivot point and out, sliding the transceiver out of the port (Figure 39).

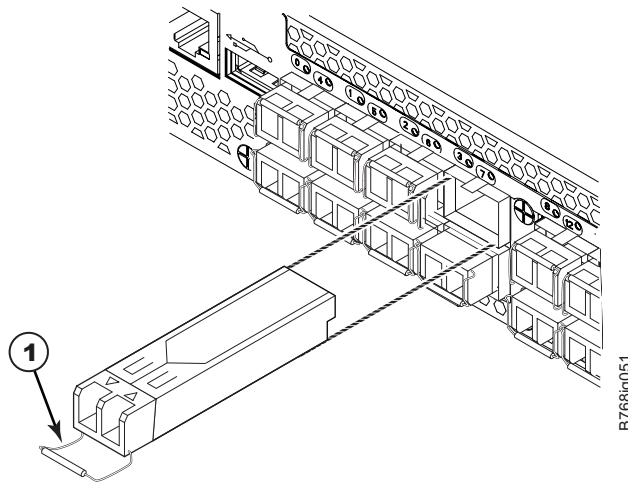

Figure 39. Removing and replacing an SFP+ optical transceiver with a wire bail

3. Set the transceiver on a static-free surface, such as a grounding pad.

Installing an SFP+ transceiver

Complete the following steps to install an SFP+ transceiver.

Note: The 16 Gbps SFP+ transceivers have an attached pull tab like the mSFPs.

Connect the cable to the 16 Gbps SFP+ first, and then insert the SFP+/cable unit into the port, using the pull tab to help push the transceiver and cable into the port. Refer to Figure 38 on page 105, which shows the 16 Gbps SFP+ without the cable attached).

1. Ensure that both cable and transceiver are clean prior to installation.
2. For SFPs and SFP+ transceivers with wire bails, make sure that the bail (wire handle) is in the unlocked position. Align the optical transceiver so that the key is oriented correctly to the port (Figure 39). Insert the transceiver into the port until it is firmly seated and the latching mechanism clicks, and then close the bail.

Transceivers are keyed so that they can only be inserted with the correct orientation. If a transceiver does not slide in easily, ensure that it is correctly oriented.

3. Position a cable so that the key (the ridge on one side of the cable connector) is aligned with the slot in the transceiver. Insert the cable into the transceiver until the latching mechanism clicks. Cables are keyed so that they can be inserted in only one way. If a cable does not slide in easily, ensure that it is correctly oriented.

Attention: Do not insert a cable intended for an mSFP transceiver into a regular SFP+ transceiver. You may damage the cable.

Removing and installing an mSFP optical transceiver

Use this procedure to remove and install mSFP transceivers. Do *not* use the extraction tool to remove mSFP transceivers

connection. Beginning with Fabric OS v7.0.1, up to nine neighboring SAN384B-2 and SAN768B-2 chassis can be connected with the QSFP cables. With Fabric OS v7.0.0, a maximum of six chassis can be connected. An off-the-shelf QSFP cable up to 50 meters long can be used as an ICL cable.

Attention: If QSFP cables are not in use, make sure the rubber gaskets are in the QSFP transceivers.

Table 14 describes the ICL connector port LED patterns and the recommended actions for those patterns.

Table 14. ICL connector port LEDs

LED purpose	Color	Status	Recommended action
QSFP connector status	No light (LED is off)	No QSFP module, all four QSFP ports are disabled	No action required if QSFP is not present or verify that the QSFP is fully inserted.
	Steady amber	QSFP module is in, all four ports have no signal/no sync.	No action required if QSFP only is installed or ensure that the cable is properly connected. If the LED remains amber, contact IBM.
	Blinking amber	Port is disabled or faulted, FC link activity, segmented, loopback mode, also during transition between QSFP cable insertion and confirmation.	Check for console messages or wait for all four ports to come online.
	Steady green	Both ends of QSFP cable are in and all ports are online. Full link is established.	No action required.

Complete this procedure to remove and install the ICL cables. Refer to the *Fabric OS Administrator's Guide* for the configuration procedure and requirements.

Figure 41 on page 109 shows a QSFP cable and transceiver. The QSFP connectors on the core blades are labeled by trunk group (trunking is optional) for ease of installation. The subsequent figures, beginning with Figure 42 on page 110, show acceptable cabling configurations for the ICL feature. The recommended topology is the parallel type where there are four QSFP cables connected between any pair of SAN384B-2 or SAN768B-2 chassis. The full mesh configuration is also supported.

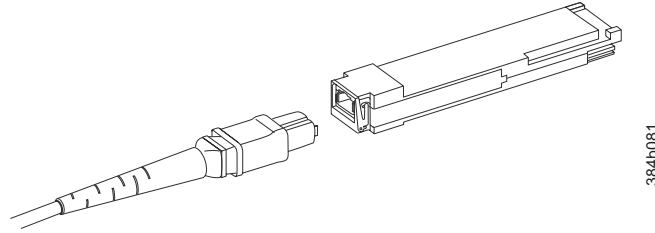

Figure 41. QSFP cable and transceiver

Time and items required

The replacement procedure for an QSFP cable takes less than five minutes. You will need a replacement QSFP cable and transceiver (if necessary).

Removing an inter-chassis link (QSFP) cable

To remove an inter-chassis link (QSFP) cable, complete these steps.

1. Remove the chassis door (“Removing and installing the chassis door” on page 79).
2. If you are replacing an ICL cable, note the cable routing, paying attention to which cable end plug into which socket. Replace only one ICL cable at a time to minimize errors.
3. Grasp the rubber housing on the end of the cable and pull it straight out of the QSFP transceiver.
4. If the QSFP transceiver also needs to be replaced, remove the QSFP transceiver by rotating the bail down and using the bail to pull the transceiver out of the connector on the blade.
5. Repeat for each cable that requires replacement.
6. If you are not replacing the ICL cables, insert the rubber plugs into each QSFP transceiver.

Installing an ICL cable

Complete the following steps to install a QSFP cable.

1. If the QSFP transceiver is being replaced, grasp the bail of the new QSFP and push the QSFP into the connector on the blade until it is firmly seated. The QSFP is keyed to fit into the connector in one way. The status LED initially blinks amber after installation, then displays steady amber.
2. Grasp the QSFP cable by the rubber housing and push it into the QSFP transceiver until it is firmly seated. The cable housing is keyed to fit into the QSFP in one way.
The status LED displays steady amber until both ends of the cable are inserted and the link is established. When the link is fully established, the LED displays steady green.
3. Repeat for each cable that you are installing.
If you are installing ICL cables for the first time, pay particular attention to the configuration in which the cables must be installed. See “Possible ICL configurations” on page 110 for one possible configuration between two chassis.
4. Replace the chassis door (“Removing and installing the chassis door” on page 79).

- Once all the cables are attached, see the *Fabric OS Administrator's Guide* for the configuration procedure.

Possible ICL configurations

Figure 42 illustrates one possible QSFP cable configuration between two SAN384B-2 or SAN768B-2 chassis. Each of two cores in one chassis should be interconnected with each of two cores in the second chassis. This provides for inter-chassis link (ICL) trunking between chassis, ensuring redundancy. Parallel connections between core blades are recommended.

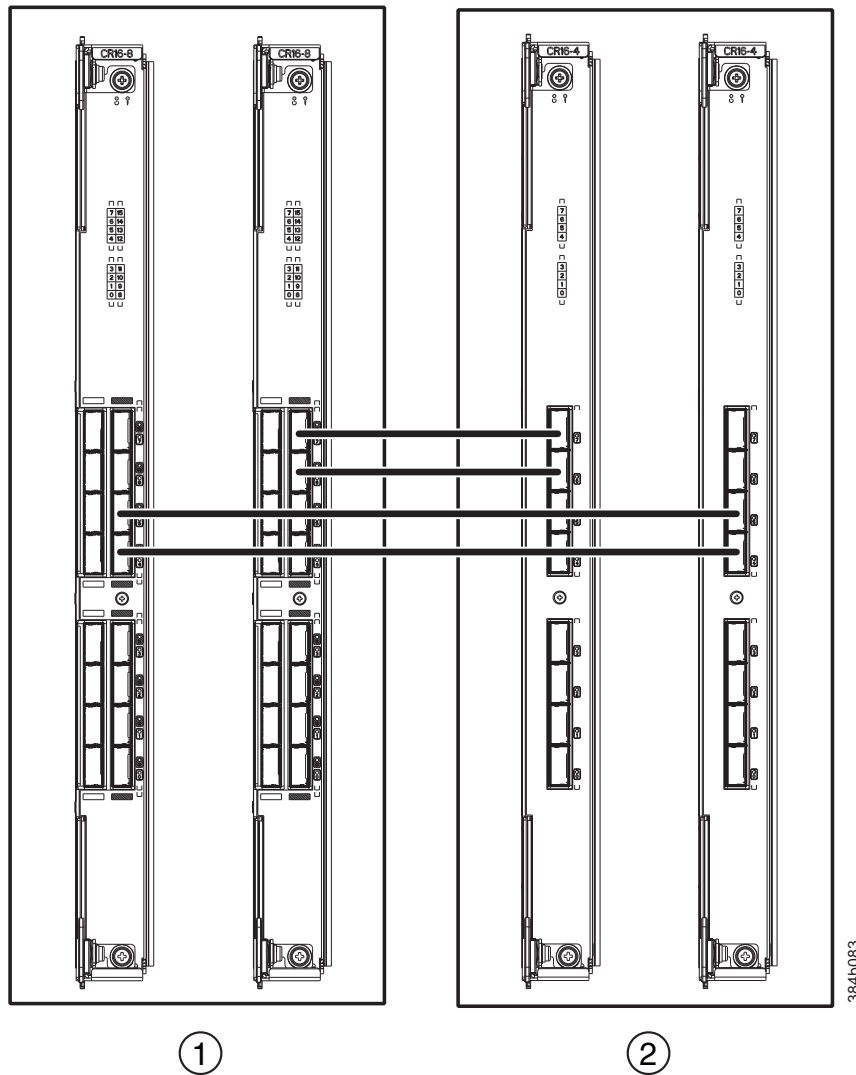

Figure 42. QSFP cable connections for two SAN768B-2 chassis (sample configuration)

- | | | | |
|----------|-----------------------|----------|-----------------------|
| 1 | Chassis 1 (SAN768B-2) | 2 | Chassis 2 (SAN768B-2) |
|----------|-----------------------|----------|-----------------------|

SAN384B-2 and SAN768B-2 chassis can be connected in a core/edge configuration. Figure 43 on page 111 shows two core and four edge chassis. Although only SAN768B-2 chassis are shown in the figure, the chassis can be any combination of SAN384B-2 and SAN768B-2. The cabling scheme should follow the parallel example shown in the Figure 42. Each line in the Figure 43 on page 111 actually

represents four cables running between the chassis.

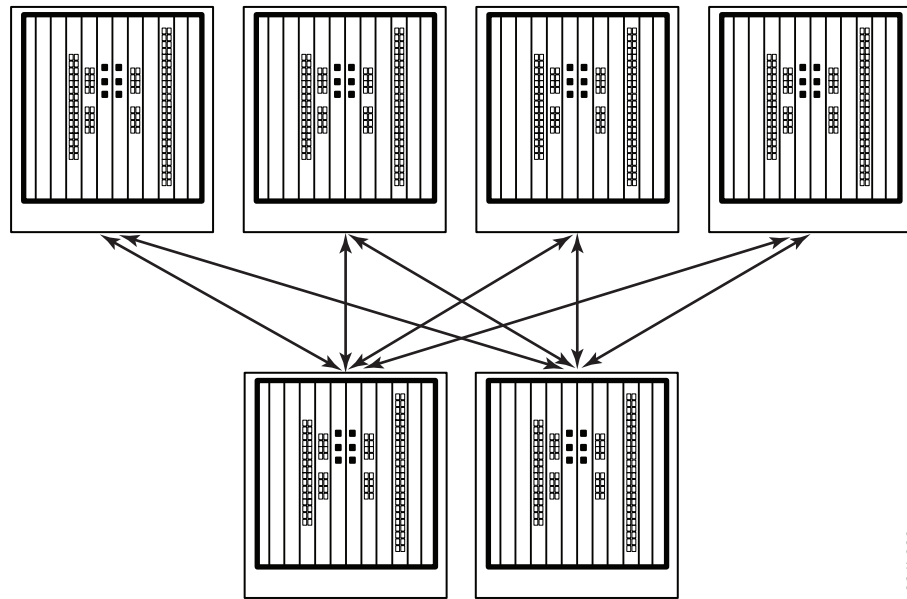

Figure 43. Core/edge ICL topology for SAN384B-2 and SAN768B-2 chassis

SAN384B-2 and SAN768B-2 chassis can also be connected in a full mesh configuration as shown in Figure 44 on page 112. The SAN768B-2 chassis are shown in the figure, but either chassis can be connected. In this example, the three trunk groups are shown in different shades.

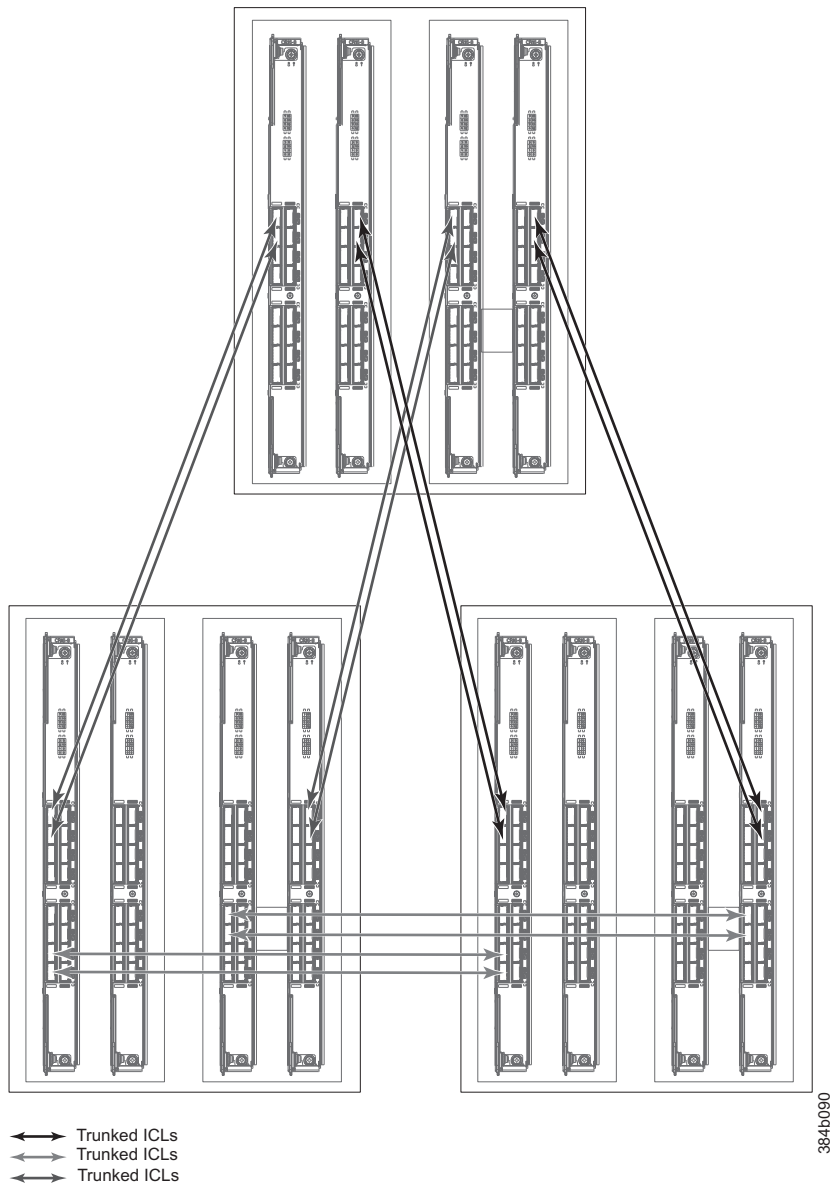

Figure 44. full mesh ICL topology for SAN384B-2 and SAN768B-2 chassis

Removing and replacing the chassis

The SAN768B-2 chassis is highly reliable and unlikely to fail. This chapter describes how to remove and replace a chassis in the unlikely event of a failure. The SAN768B-2 must be removed from the fabric and powered off to perform this procedure. Contact IBM if you have any questions about whether the SAN768B-2 chassis requires replacement. This procedure is to be completed only by a qualified IBM service representative.

Refer to the following sections of this chapter for specific information:

- “Verifying necessity of replacement” on page 113
- “Preparing for a chassis replacement” on page 113
 - “Time required” on page 113

- “Items required”
- “Recording critical SAN768B-2 and SAN information” on page 114
- “Disconnecting the SAN768B-2 from the network and fabric” on page 117
- “Removing components from the chassis” on page 117
- “Removing and replacing the chassis from the cabinet” on page 118
- “Installing components into the new chassis” on page 118
- “Verifying the correct operation of the system” on page 120
- “Reconnecting the system to the network and fabric” on page 121
- “Verifying the correct configuration of the fabric” on page 122

Note: The SAN768B-2 must be removed from the fabric and powered off to perform this procedure. Contact IBM Support if you have any questions about whether the chassis requires replacement.

Verifying necessity of replacement

Before replacing the chassis, verify that the replacement is necessary. Ensure that the components are firmly seated when troubleshooting. Contact IBM if you have any questions about whether the chassis should be replaced.

Any of the following events might indicate that the chassis requires replacement:

- Visible mechanical damage to the chassis, including damage to sheet metal or blade guides that prevents correct installation of a component.
- Bent or damaged connectors on the main backplane (the surface inside the chassis to which the various blades connect)
- One or more SAN768B-2 components (such as a power supply, blower assembly, port blade, CP blade, or WWN card) do not function properly even after the component is replaced.
- Intermittent FAULTY codes for blades. Re-seat the blade and visually inspect the top ejector stiffening rail for possible wear or damage. It is important that the blade ejector handles not slip out during blade installation. If this happens, it is usually due to excessive wear or damage to the top ejector stiffening rail.
- The **psShow** or **fanShow** commands continue to show a faulty component even though the component has been replaced.
- The **slotShow** command continues to show a faulty processor, core switch, or port blade even though the blade has been replaced.

Preparing for a chassis replacement

Use the following information to help prepare for a chassis replacement.

Attention: Refer to “Safety notices and labels” on page xiii before performing any removal or installation procedures.

Time required

The chassis replacement procedure takes approximately 3 hours to complete.

Items required

The following items are required for the chassis replacement procedure:

- ESD grounding strap.
- ESD grounding pads for protecting all blades and WWN cards

- Serial cable and workstation computer with a terminal emulator application (such as HyperTerminal for Windows systems or TIP for Solaris systems), required only if serial console session used.
- Lifting tool (see “Ordering the lift tool” on page 14).
- A surface to place the old chassis on, such as a second lift or the pallet originally provided with the old chassis.
- Torque wrench with #2 Phillips screwdriver tip (if switch is installed in a cabinet).
- #2 slotted screwdriver.

Recording critical SAN768B-2 and SAN information

All commands must be entered from a CLI session (Telnet or serial) to the active CP blade unless otherwise indicated. For detailed information about Fabric OS commands, refer to the *Fabric OS Command Reference*. Use a checklist to ensure that all required information is recorded (see Table 15).

Note: Run **supportShow**, which will provide most of the information in Table 15 and more. The customer should also record the location of the .txt files, which are created by the customer and are not called out in the **supportShow** results.

Table 15. Critical information checklist example

Checked?	Data	Notes
Configuration information		
	Location of "config-switch.txt" file:	
	Location of "config-miscinfo.txt" file:	
	IP address, subnet mask:	
	WWN for SAN768B-2:	
SAN profile		
	Location of "SANbefor.txt" file:	
	Notes regarding nsShow output:	
	Notes regarding nsAllShow output:	
	Notes regarding switchShow output:	
	Notes regarding fabricShow output:	
Output from supportShow command		
	Location of "spptshow.txt" file:	
	Notes regarding supportShow output:	
Information about the new chassis		
	New factory serial number:	
	New serial number (if available):	

Complete the following steps to record critical switch and SAN information:

1. Open a Telnet session and login to the SAN768B-2 as **admin**. The default password is **password**. Refer to your records for current passwords. Enable the logging function on your Telnet or serial console connection.
2. Back up the current configuration.

Note: If you are using the virtual fabric feature, you should run **configupload -vf** before running the **configupload** command in order to save the logical switch configuration.

Enter **configUpload -all**; then enter the requested information at the prompts. This command uploads the chassis configuration to the customer-defined FTP server, making it available for downloading. For more information about this command, refer to the *Fabric OS Command Reference*.

```
switch:admin> configupload -all
Protocol (scp or ftp) [ftp]: ftp
Server Name or IP Address [host]: 123.123.123.123
User Name [user]: Admin24
File Name [config.txt]: config-switch0.txt
Password:
Upload complete
switch:admin>
```

Alternatively, you can save the configuration file to the USB device.

3. Record the SAN768B-2 values on a workstation, following steps 4 through 9 on page 116 below.

4. Record the WWN value: Enter **wwn**, then copy the command output into a file named configmiscinfo.txt.

```
switch:admin> wwn
10:00:00:60:69:00:00:0a
```

5. Record the IP address information. Enter **ipAddrShow -sw**, then copy the command output into the config-miscinfo.txt file.

```
switch:admin> ipaddrshow -sw
Ethernet IP Address: 10.32.50.12
Ethernet Subnetmask: 255.55.0.0
Fibre Channel IP Address: 1.2.3.4
Fibre Channel Subnetmask: 255.255.255.0
CP0
Ethernet IP Address: 10.32.50.10
Ethernet Subnetmask: 255.55.0.0
HostName : cp0
Gateway Address: 10.32.40.1
CP1
Ethernet IP Address: 10.32.50.11
Ethernet Subnetmask: 255.55.0.0
HostName : cp1
Gateway Address: 10.32.40.1
Backplane IP address of CP0 : 10.0.0.6
Backplane IP address of CP1 : 10.0.0.7
switch:admin>switch:admin>
```

6. Display and record the manufacturer serial numbers. Enter **chassisShow**, then copy the command output into the config-miscinfo.txt file.

"Factory Serial Num" and "Serial Num" are listed under "Chassis/WWN Unit 1." If the current WWN cards are the original cards, the factory serial number listed is the same as the chassis serial number. If a "Serial Num" value displays, contact IBM to determine whether this serial number should be modified after the new WWN card is installed.

```
switch:admin> chassisshow
Chassis Backplane Revision: 1F
SW BLADE Slot: 1
Header Version: 2
Power Consume Factor: -50
Factory Part Num: 60-0001532-03
Factory Serial Num: KP000000195
Manufacture: Day: 1 Month: 1 Year: 2011
Update: Day: 14 Month: 3 Year: 2011
Time Alive: 187 days
```

```

Time Awake: 3 days
<output truncated>
CHASSIS/WWN Unit: 1 (in same assembly as WWN Unit: 2)
Header Version: 2
Power Consume Factor: -3
Factory Part Num: 60-0001501-07
Factory Serial Num: FT02X805BE2
Manufacture: Day: 26 Month: 3 Year: 2011
Update: Day: 14 Month: 3 Year: 2011
Time Alive: 207 days
Time Awake: 3 days
<output truncated>
switch:admin>

```

7. Create a SAN profile by entering and recording the information provided by the following commands:

- **nsShow**
- **nsAllShow**
- **switchShow -qsfp**
- **fabricShow**

Copy the command output into a text file named SANbefor.txt. After the SAN768B-2 is restored to the fabric, this information can be used to verify that no unintentional changes have occurred to the fabric.

```

switch:admin> nsshow
Enter Pid COS PortName NodeName TTL
<output truncated>
switch:admin> nsallshow
12 Nx_Ports in the Fabric
<output truncated>
switch:admin> switchshow
switchName: switch
<output truncated>
switch:admin> fabricshow
Switch ID Worldwide Name Enet IP Addr FC IP Addr Name
<output truncated>
switch:admin>

```

8. Enter **supportShow**, then copy the command output into a text file named sptshow.txt.

Note: The **supportShow** command has very long output and time for completion. It may last 20 minutes or longer depending on the size of the SAN.

This file provides a backup of all the information that might be required by Technical Support. The information can be used after the SAN768B-2 is restored to the fabric, to verify that no unintentional changes have occurred to the fabric

```

switch:admin> supportshow
version: 7.0.0
<output truncated>

```

```
switch:admin>
```

9. Record the cable connections between the SAN768B-2 and the target devices and ports. (See “Cable routing tables” on page 123).
10. Run **supportSave** on the active CP. The information recorded can be very important in case you have difficulties during the replacement process.

Disconnecting the SAN768B-2 from the network and fabric

To disconnect the SAN768B-2 from the network and fabric, complete these steps:

1. Shut down the system by entering the **sysShutdown** command.

```
switch:admin> sysshutdown  
This command will shutdown the operating systems on your switch.  
You are required to power-cycle the switch in order to restore operation.  
Are you sure you want to shutdown the switch [y/n]? y  
HA is disabled  
Stopping blade 1  
Shutting down the blade....  
Stopping blade 2  
Shutting down the blade....  
Stopping blade 8  
Shutting down the blade....  
Broadcast message from root (pts/1) Mon Jul 18 14:23:06 2011...  
The system is going down for system halt NOW !!
```
2. Power off the chassis by flipping all ac power switches to the off position "O" (the LEDs inside the clear plastic ac power switches should turn off).
3. Remove the power cords from the power supplies and the power outlets.
4. Label the cables connected to all blades, if not already labeled, and record the connections in the "Cable routing tables" on page 123, making extra copies as needed.
5. Disconnect the cables from the SFP+ transceivers in the application and port blades and set them aside. If you have mSFP transceivers in FC8-64 port blades, remove the transceivers and cables together and set them aside. The SFP+ transceivers can be left in the port blades or removed.

Note: Follow the instructions in "Removing and installing an SFP+ optical transceiver" on page 105 for more details.

6. Disconnect all cables from the control processor and core switch blades.
7. Disconnect any QSFP cables (see "Removing and replacing inter-chassis link (QSFP) cables" on page 107).

Removing components from the chassis

Attention: Before removing any components, refer to "Safety notices and labels" on page xiii, and particularly to "Rack safety" on page xx to ensure that any component removals and installations do not affect the stability of the cabinet.

Attention: Follow ESD precautions (see "ESD precautions" on page xix)

You must remove the field replaceable units (FRUs) from the SAN768B-2 chassis in the order listed below. Refer to the instructions in Chapter 5, "Removing and installing components," on page 79 for component-specific removal instructions.

1. Remove the cable management comb as described in "Removing and installing a cable management comb" on page 80.
2. Remove the port blades or filler panels as described in "Removing and installing port, application, and encryption blades" on page 81 and "Removing and installing blade filler panels" on page 84.
3. Remove the core switch blades (CR16-8) as described in "Removing and installing a core switch blade (CR16-8)" on page 95
4. Remove the control processor blades (CP8) as described in "Removing and installing a CP8 control processor blade" on page 85.

5. Remove the power supply units or filler panels as described in “Removing and installing a power supply” on page 98.
6. Remove the blower assembly as described in “Removing and installing a blower assembly” on page 100.
7. Remove the WWN bezel and card as described in “Installing the WWN bezel and WWN card” on page 103.

Removing and replacing the chassis from the cabinet

Although the empty chassis is lighter than a fully populated chassis, a lifting device is still required to move it. Refer to “Removing a SAN768B-2 from the cabinet” on page 31 for more detailed instructions on removing a SAN768B-2 from a cabinet. The instructions below only provide an outline of the steps required to complete this process.

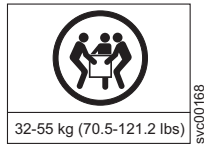

CAUTION:

The weight of this part or unit is at least 47 kg (104 lb) with all components removed. It takes specially-trained persons and/or a lifting device to safely lift this part or unit. (C011)

Attention: Do not place a SAN768B-2 chassis directly on the floor. It cannot be easily moved from the floor back onto a lift or pallet.

1. Uninstall the chassis from the cabinet (see “Removing a SAN768B-2 from the cabinet” on page 31 for detailed steps) and place it onto an extra lift or on the shipping pallet originally provided with the chassis. Remove the mounting brackets, and set the hardware aside for use with the new chassis.
2. Unpack the new chassis (see “Unpacking the SAN768B-2” on page 19)
3. Attach the brackets to the new chassis (see “Attaching the shelf brackets” on page 20)
4. Install the new chassis in the cabinet, using a lift tool to raise the chassis to the correct level. See “Using the lift tool, the 24-inch load plate, and the bridge tool” on page 22 for detailed steps.

Installing components into the new chassis

Install the components into the new SAN768B-2 chassis in the order listed below. Refer to Chapter 5, “Removing and installing components,” on page 79 for more specific installation information.

Attention: Do not force the installation of any of the components. If the component does not slide in easily, ensure that it is correctly aligned and positioned before continuing.

Attention: Do not turn on the power until it is time to verify hardware operation

Attention: Follow ESD precautions (“ESD precautions” on page xix)

1. Install the WWN cards and bezel in the new chassis as described in “Installing the WWN bezel and WWN card” on page 103.
2. Install the blower assemblies in the new chassis as described in “Removing and installing a blower assembly” on page 100.
3. Install the power supplies or filler panels in the new chassis as described in “Removing and installing a power supply” on page 98.

4. Install the control processor (CP8) blades in the new chassis as described in “Removing and installing a CP8 control processor blade” on page 85.
5. Replace the core switch blades (CR16-8) as described in “Removing and installing a core switch blade (CR16-8)” on page 95
6. If QSFP cables are not used, insert the rubber plugs in the sockets in the QSFP transceivers.
7. Install the port, application blades, or filler panels in the new chassis as described in “Installing a blade” on page 83 or “Installing a filler panel” on page 85.
8. Replace the cable management comb “Removing and installing a cable management comb” on page 80
9. Connect the power cords to the power supplies and the power outlets.
10. Install the chassis door as described in “Removing and installing the chassis door” on page 79.
11. Power-on the chassis “Providing power to the SAN768B-2” on page 37. The system performs a power-on self-test (POST). The POST takes a minimum of three minutes and is complete when LED activity returns to standard state.
12. Verify that the POST is complete. All power LED indicators on the port, control processor, and core switch blades should be a steady green.
13. Verify that all components are functioning correctly by checking their LEDs. If the LEDs do not indicate correct operation, try reinstalling the corresponding component.

Downloading the configuration

Once the chassis and its various components have been reassembled and powered back on, use the **configDownload** command to restore the original configuration. The **configDownload** command can be entered through a Telnet or serial session, but the chassis must have an Ethernet connection to the server name or IP of the host for the download process to complete. For more information, refer to the **help configdownload** command or the *Fabric OS Command Reference*.

Complete the following steps to download the configuration.

1. Log in to the chassis as **admin**:

```
switch:admin> login
login: admin
password: xxxxxxxx
switch:admin>
```

Note: If you are using the Virtual Fabric feature, you should run **configdownload -vf** before running the **configdownload** command in order to restore the logical switch configuration.

2. Enter **configDownload** command:

```
switch:admin> configdownload -all
Server Name or IP Address [host]: 123.123.123.123
User Name [None]: Admin24
File Name [config.txt]: config-switch.txt
Password: xxxxxxxx
download complete
switch:admin>
```

3. Reboot the system.

Verifying the correct operation of the system

Complete these steps to verify that the hardware is operating correctly.

1. Log in to the SAN768B-2 as **admin**:

```
switch:admin> login
login: admin
password: xxxxxxxx
switch:admin>
```

2. Enter the **slotShow -m** command and verify that all the installed cards are detected and that their status is operational (enabled).

```
switch:admin> slotShow -m
```

```
Slot Blade Type ID Model Name Status
-----
1 SW BLADE 97 FC16-32 ENABLED
2 SW BLADE 77 FC8-64 ENABLED
3 SW BLADE 97 FC16-32 ENABLED
4 SW BLADE 97 FC16-32 ENABLED
5 CORE BLADE 99 CR16-8 ENABLED
6 CP BLADE 50 CP8 ENABLED
7 CP BLADE 50 CP8 ENABLED
8 CORE BLADE 99 CR16-8 ENABLED
9 SW BLADE 96 FC16-48 ENABLED
10 SW BLADE 77 FC8-64 ENABLED
11 SW BLADE 96 FC16-48 ENABLED
12 SW BLADE 77 FC8-64 ENABLED
switch:admin>
```

3. Verify that the SAN768B-2 is functioning correctly by entering **switchShow** or **switchStatusShow**. The **switchShow** command displays chassis and port status information.

```
switch:admin> switchshow
switch:FID128:root> switchshow
switchName: SAN768B-2_8
switchType: 120.1
switchState: Online
switchMode: Native
switchRole: Subordinate
switchDomain: 80
switchId: fffc50
switchWwn: 10:00:00:05:1e:39:e4:5a
zoning: ON (ZONE_CONFIG_NAME)
switchBeacon: OFF
FC Router: OFF
Allow XISL Use: OFF
LS Attributes: [FID: 128, Base Switch: No, Default Switch: Yes, Address Mode
0]
Index Slot Port Address Media Speed State Proto
=====
0 1 0 500000 -- 4G No_Module FC
1 1 1 500100 -- 4G No_Module FC
2 1 2 500200 -- 4G No_Module FC
3 1 3 500300 -- 4G No_Module FC
4 1 4 500400 -- 4G No_Module
<output truncated>
```

4. Verify that all the IP address information is correct by entering the **ipAddrShow** command and checking the results against the IP information recorded in the config-miscinfo.txt file.

```
switch:admin> ipaddrshow
SWITCH
Ethernet IP Address: xxx.xxx.xxx.12
Ethernet Subnetmask: 255.55.0.0
Fibre Channel IP Address: 1.2.3.4
Fibre Channel Subnetmask: 255.255.255.0
```

```
CP0
Ethernet IP Address: xxx.xxx.xxx.10
Ethernet Subnetmask: 255.55.0.0
HostName : cp0
Gateway Address: xxx.xxx.xxx.1

CP1
Ethernet IP Address: xxx.xxx.xxx.11
Ethernet Subnetmask: 255.55.0.0
HostName : cp1
Gateway Address: xxx.xxx.xxx.1

Backplane IP address of CP0 : 10.0.0.5
Backplane IP address of CP1 : 10.0.0.6
switch:admin>switch:admin>
```

Reconnecting the system to the network and fabric

Attention: Refer to “Managing cables” on page 46 for information on how to physically manage the arrangement of the cables within the SAN768B-2 chassis, and cautions on handling and routing the cables.

Refer to the cable routing information recorded in “Cable routing tables” on page 123 to ensure the correct cable connections in the steps below.

Complete the following steps to reconnect the system to the network and fabric.

1. Connect the CP blades to the local area network, one blade at a time.
 - a. Insert the appropriate Ethernet cables into each Ethernet port.
 - b. Connect the other ends to an Ethernet 10/100/1000 Base-T LAN, if not already connected.

Note: The SAN768B-2 can be accessed by remote connection using any of the available management tools, such as Telnet or Web Tools. Ensure that the SAN768B-2 is not modified from other connections during the rest of this procedure.

2. Reconnect the transceivers and cables to the port blades, as required (see “Removing and installing transceivers” on page 104) for details.

Note: The ports and cables used in trunking groups must meet specific requirements. For a list of these requirements, refer to the *Fabric OS Administrator’s Guide*.

- a. Install a transceiver into each port, if not already installed (see “Removing and installing transceivers” on page 104).
- b. Select the cable that corresponds to the port and position it so that the key (the ridge on one side of the cable connector) is aligned with the slot in the transceiver. Insert the cable into the transceiver until the latching mechanism clicks.
- c. Repeat step b for each remaining port on the blade.

Attention: Do not route cables in front of the air exhaust vent (located on the upper port side of the chassis.)

The minimum bend radius should be no smaller than 10x the cable radius.

Tie wraps are not recommended for optical cables because they are easily overtightened and can unknowingly break the cable causing connectivity problems.

- d. Repeat steps a through c for each of the remaining port and application blades.
3. Organize the cables as required (see "Managing cables" on page 46).

Verifying the correct configuration of the fabric

Details on configuring the fabric are included in the *Fabric OS Administrator's Guide* and the *Fabric OS Command Reference*, which are included on the product documentation CD shipped with the product.

Copying the command outputs from this section into a file is recommended. Verify the correct configuration of the fabric by following the steps below.

1. Create an "after" SAN profile by entering the following commands and copying the output to a text file named "SANafter.txt".
 - **nsShow**
 - **nsAllShow**
 - **switchShow**
 - **fabricShow**
 - **lscfg --show** (if using the virtual fabric feature)

```
switch:admin> nsshow
Type Pid COS PortName NodeName TTL(sec)
N 020f00; 3;10:00:00:01:73:00:29:46;10:00:00:01:73:00:29:46; na
Fabric Port Name: 20:0f:00:60:69:90:03:f0
<output truncated>
```

```
switch:admin> nsallshow
{
020f00 021fda 021fdc 021fe0 021fe1
5 Nx_Ports in the Fabric}
```

```
switch:admin> switchshow
switchName: swDir
<output truncated>
```

```
switch:admin> fabricshow
Switch ID Worldwide Name Enet IP Addr FC IP Addr Name
<output truncated>
switch:admin>
```

```
switch:admin> lscfg --show
Created switches: 128(ds) 1 2(bs)
Port 0 1 2 3 4 5 6 7 8 9
-----
FID 1 | 1 | 1 | 1 | 1 | 128 | 128 | 128 | 128 | 128 |
```

<output truncated>

switch:admin>

2. Determine any differences between the information in the "SANafter.txt" file and the information in the "SANbefor.txt" file created earlier. In particular, look for differences in the following items:
 - Device types
 - Number of devices
 - ISL and port states
 - Number of switches in the fabric
3. Resolve any issues or unintentional changes to the SAN768B-2 or fabric.
 - If there are any mechanical problems, try reseating the associated component.
 - If the configuration information is not correct for the SAN768B-2, modify as required.
 - If other issues exist, contact technical support.

Cable routing tables

Table 16 provides a sample of cable routing information. Create your own table, or use copies of Table 17 to record this information, if it is not already available. Table 17 is a 64-port template for a cable routing table. Make copies of the table to cover the total number of ports in the system.

Table 16. Sample cable routing table for SAN768B-2

Slot/Port	Cable labels		Connected device	Slot/Port of device
	Switch end	Device end		
Slot 1 Port 0	North 24 - 1/0	East 26 - 0	SANB32 East 26	0
Slot 5 Serial	North 24 - 5 / Serial	Work 5 - 2	Workstation 5	Com 2
Slot 8 Port 15	North 24 - 8/15	RAID 16 - 4	RAID 16	4

Table 17. Cable routing table for SAN768B-2 (64 ports shown)

Slot/Port		Cable labels		Connected device	Slot/Port of device
Slot	Port	Switch end	Device end		
	0				
	1				
	2				
	3				
	4				
	5				
	6				
	7				
	8				
	9				
	10				
	11				
	12				

Table 17. Cable routing table for SAN768B-2 (64 ports shown) (continued)

Slot/Port		Cable labels		Connected device	Slot/Port of device
Slot	Port	Switch end	Device end		
	13				
	14				
	15				
	16				
	17				
	18				
	19				
	20				
	21				
	22				
	23				
	24				
	25				
	26				
	27				
	28				
	29				
	30				
	31				
	32				
	33				
	34				
	35				
	36				
	37				
	38				
	39				
	40				
	41				
	42				
	43				
	44				
	45				
	46				
	47				
	48				
	49				
	50				
	51				

Table 17. Cable routing table for SAN768B-2 (64 ports shown) (continued)

Slot/Port		Cable labels		Connected device	Slot/Port of device
Slot	Port	Switch end	Device end		
	52				
	53				
	54				
	55				
	56				
	57				
	58				
	59				
	60				
	61				
	62				
	63				

Removing the batteries

Local regulations may require removal of the battery before recycling or disposing of the product. Batteries are located in the control processor blades (CP8) and also in optional Encryption blades (FS8-18). Follow these steps to remove the batteries from the product:

CAUTION:

The battery contains lithium. To avoid possible explosion, do not burn or charge the battery.

DO NOT:

- Throw or immerse into water
- Heat to more than 100°C (212°F)
- Repair or disassemble

Exchange only with the IBM-approved part. Recycle or discard the battery as instructed by local regulations. In the United States, IBM has a process for the collection of this battery. For information, call 1-800-426-4333. Have the IBM part number for the battery unit available when you call. (C003)

1. Remove any installed modules.
2. Remove any installed power supplies.
3. Unscrew fasteners and remove any fan trays or fan assemblies.
4. Unscrew fasteners, unplug all connectors and remove any Printed Circuit Board Assembly (PCBA) from the fan trays or fan assemblies.
5. In the two control processor blade (CP8) assemblies, locate the central processor PCBAs.
6. Go to the following locations and remove the two BR1225 batteries from each of the PCBAs (see **1** in Figure 45 on page 126):
 - a. XB1
 - b. XB

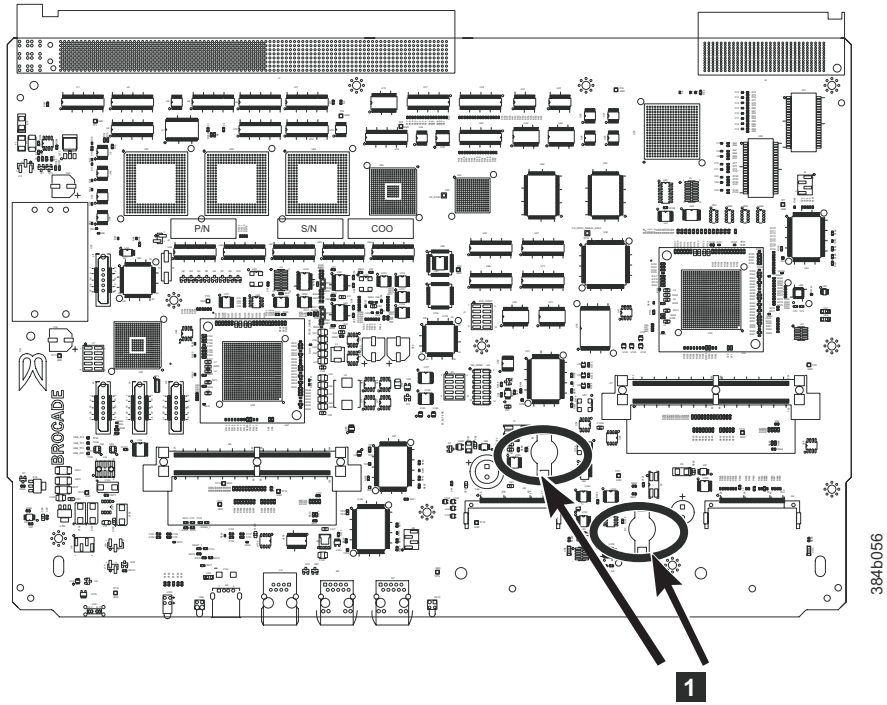

Figure 45. Battery locations on the CP8 blade

7. For the optional FS8-18 encryption blade, go to the BC1 location (see **1** in Figure 46) on the main board and remove the BR1225 battery.

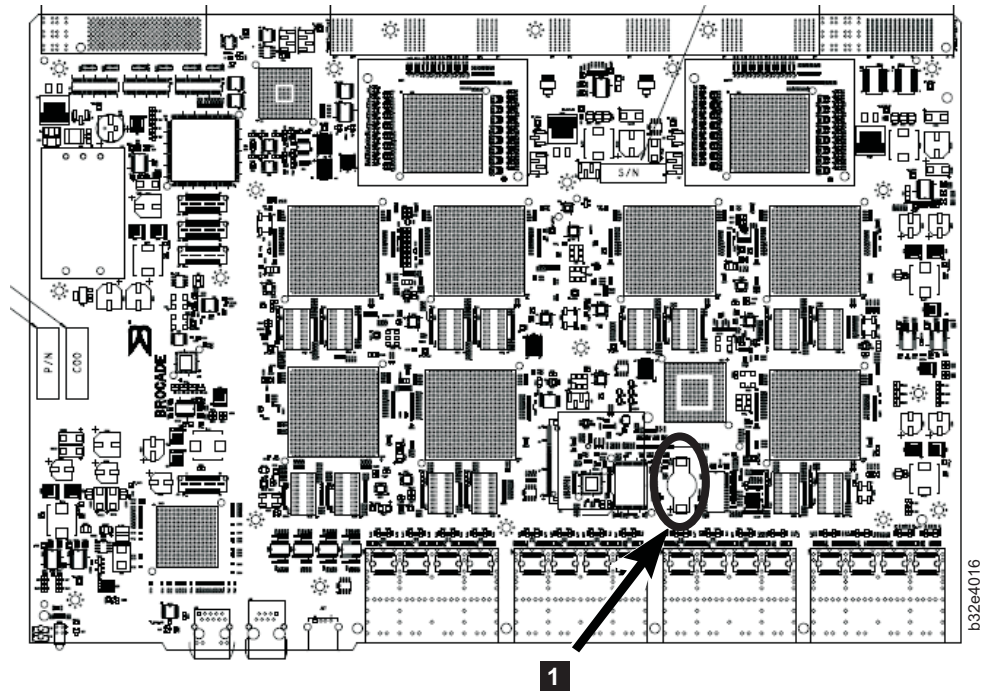

Figure 46. Encryption blade battery location

8. Recycle the batteries as appropriate.

Refer to the *Environmental Notices and User Guide* shipped with the product for more information on battery recycling and disposal.

Chapter 6. Installing new features

Attention: Refer to “Safety notices and labels” on page xiii before performing any service or installation procedures.

The SAN768B-2 can be upgraded with any of the following hot-pluggable features while the SAN768B-2 is operational. Refer to the individual feature installation instructions for any possible exceptions.

Use this chapter as a starting point when installing new features on an existing SAN768B-2. Installation instructions link from here to the appropriate sections.

- “FC3632, FC3648- Installing a 16-Gb port port blade (32 or 48 ports)”
- “FC3633, FC3649- Installing an Enhanced 8-Gb port blade (32 or 48 ports)” on page 131
- “FC3864 - Installing an 8-Gb 64-port port blade” on page 132
- “FC3890 - Installing an Extension Blade (FX8-24)” on page 134
- “FC3895 - Installing an Encryption Blade (FS8-18)” on page 135
- “FC7230 - Installing FIPS 140-2 Level 2 tamper proof seals” on page 137
- “FC7871 - Installing a QSFP and inter-chassis license” on page 137
- “FC7873 - Installing a QSFP and Enterprise inter-chassis license” on page 138

FC3632, FC3648- Installing a 16-Gb port port blade (32 or 48 ports)

These features can be installed while the SAN768B-2 is operational.

Attention: Follow these precautions for all procedures in this section to avoid damaging the port blades or chassis:

- Wear a grounded ESD strap when handling a port blade (see “ESD precautions” on page xix).
- Carefully remove the protective strip (if any) covering the blade connectors before installing any blades.
- Do not force the port blade installation. If the port blade does not slide in easily, ensure that it is correctly aligned inside the rail guides before continuing. Installing a port blade with incorrect alignment damages both the chassis and the replacement part.
- Hold the port blade by the edges of the metal pan. Do not use the ejectors to hold a port blade.
- Disassembling any part of a port blade voids the part warranty and regulatory certifications. There are no user-serviceable parts inside the port blade.

These instructions cover installing a new FC3632 or FC3648 in the SAN768B-2 chassis.

Time required

20 minutes or less per port blade.

Items required

- ESD (electrostatic discharge) grounding strap
- Workstation computer
- Port blade
- Phillips screwdriver
- SFP+ transceivers (as needed)
- Optical cables (as needed)

Procedures

Follow the links in the steps below to complete this installation:

1. Verify that the port blade is the correct part: 99Y0347 for the 32-port blade, and 99Y0350 for the 48-port blade.
2. Verify which slot to install the blade. Slots are numbered from one through twelve, from left to right, when facing the port side of the SAN768B-2s. Port blades can be installed in any of the slots 1-4 and 9-12.
3. We recommend having the latest firmware version on the CP blade. The firmware version should match on both the active and the backup CP blades. If the firmware is not at the latest level, obtain new code from the code download website, and install it prior to installing the port blade. See “Fabric OS firmware updates” on page 50 for instructions. Also refer to “Removing and installing a CP8 control processor blade” on page 85 for details on firmware updates.

Note: Firmware downloads require that Ethernet connections be made to both CP blades. Procedures for downloading and installing firmware are described in the *Fabric OS Administrator’s Guide*.

4. Remove the filler panel or port blade. Refer to “Removing a blade” on page 82 or “Removing a filler panel” on page 84.
Attention: A filler panel should be removed only when being replaced with a port blade or new filler panel. Any slot that is not occupied by a port blade should be occupied by a filler panel to ensure correct cooling of the chassis and protection from dust.
5. Follow the instructions for “Installing a blade” on page 83.
6. Follow the instructions for “Removing and installing transceivers” on page 104. Because of port density, it may be easier to remove and install the SFP+ transceivers while the 32-port or 48-port blade is out of the chassis. However, you must handle the blade carefully while it is out of the chassis to avoid damaging the blade and the transceivers.
7. Install, group, and route the cables. See “Managing cables” on page 46 for additional cabling instructions.
Attention: Do not route cables in front of the exhaust vent, which is located at the top on the port side of the chassis.
8. Verify the installation. For information about how to check the status of hardware components using the CLI, see the *Fabric OS Administrator’s Guide*, which is located on the product documentation CD.

FC3633, FC3649- Installing an Enhanced 8-Gb port blade (32 or 48 ports)

These features can be installed while the SAN768B-2 is operational.

Note: A minimum level of FOS 7.0.1 is required for these blades.

Attention: Follow these precautions for all procedures in this section to avoid damaging the port blades or chassis:

- Wear a grounded ESD strap when handling a port blade (see “ESD precautions” on page xix).
- Carefully remove the protective strip (if any) covering the blade connectors before installing any blades.
- Do not force the port blade installation. If the port blade does not slide in easily, ensure that it is correctly aligned inside the rail guides before continuing. Installing a port blade with incorrect alignment damages both the chassis and the replacement part.
- Hold the port blade by the edges of the metal pan. Do not use the ejectors to hold a port blade.
- Disassembling any part of a port blade voids the part warranty and regulatory certifications. There are no user-serviceable parts inside the port blade.

These instructions cover installing a new FC3633 or FC3649 in the SAN768B-2 chassis.

Time required

20 minutes or less per port blade.

Items required

- ESD (electrostatic discharge) grounding strap
- Workstation computer
- Port blade
- Phillips screwdriver
- SFP+ transceivers (as needed)
- Optical cables (as needed)

Procedures

Follow the links in the steps below to complete this installation:

1. Verify that the port blade is the correct part, 98Y2255 for the 32-port blade, and 98Y2270 for the 48-port blade.
2. Verify which slot to install the blade. Slots are numbered from one through twelve, from left to right, when facing the port side of the SAN768B-2s. Port blades can be installed in any of the slots 1-4 and 9-12.
3. We recommend having the latest firmware version on the CP blade. A minimum level of FOS 7.0.1 is required for these blades. The firmware version should match on both the active and the backup CP blades. If the firmware is not at the latest level, obtain new code from the code download website, and install it prior to installing the port blade. See “Fabric OS firmware updates” on page 50 for instructions.

Note: Firmware downloads require that Ethernet connections be made to both CP blades. Procedures for downloading and installing firmware are described in the *Fabric OS Administrator's Guide*.

4. Remove the filler panel or port blade. Refer to "Removing a blade" on page 82 or "Removing a filler panel" on page 84.

Attention: A filler panel should be removed only when being replaced with a port blade or new filler panel. Any slot that is not occupied by a port blade should be occupied by a filler panel to ensure correct cooling of the chassis and protection from dust.

5. Follow the instructions for "Installing a blade" on page 83.
6. Follow the instructions for "Removing and installing transceivers" on page 104. Because of port density, it may be easier to remove and install the SFP+ transceivers while the 32-port or 48-port blade is out of the chassis. However, you must handle the blade carefully while it is out of the chassis to avoid damaging the blade and the transceivers.
7. Install, group, and route the cables. See "Managing cables" on page 46 for additional cabling instructions.

Attention: Do not route cables in front of the exhaust vent, which is located at the top on the port side of the chassis.

8. Verify the installation. For information about how to check the status of hardware components using the CLI, see the *Fabric OS Administrator's Guide*, which is located on the product documentation CD.

FC3864 - Installing an 8-Gb 64-port port blade

This feature can be installed while the SAN768B-2 is operational.

Attention: Follow these precautions for all procedures in this section to avoid damaging the port blades or chassis:

- Wear a grounded ESD strap when handling a port blade.
- Carefully remove the protective strip (if any) covering the blade connectors before installing any blades.
- Do not force the port blade installation. If the port blade does not slide in easily, ensure that it is correctly aligned inside the rail guides before continuing. Installing a port blade with incorrect alignment damages both the chassis and the replacement part.
- Hold the port blade by the edges of the metal pan. Do not use the ejectors to hold a port blade.
- Disassembling any part of a port blade voids the part warranty and regulatory certifications. There are no user-serviceable parts inside the port blade.

These instructions cover installing a new FC3864 in the SAN768B-2 chassis.

Time required

20 minutes or more per port blade due to port and cable density

Items required

- ESD (electrostatic discharge) grounding strap
- Workstation computer
- Port blade
- Phillips screwdriver

- mSFP transceivers (as needed)
- OM-3 LC optical cables (as needed)

Procedures

Follow the links in the steps below to complete this installation:

1. Remove the chassis door. See “Removing and installing the chassis door” on page 79.
2. Verify that the port blade is the correct part (45W7566)
3. Verify which slot to install the blade. Slots are numbered from one through ten, from left to right, when facing the port side of the SAN768B-2s. Port blades can be installed in any of the slots 1-4 and 9-12.
4. We recommend having the latest firmware version on the CP blade. If the firmware is not at the latest level, obtain new code from the code download website, and install it prior to installing the port blade. See “Fabric OS firmware updates” on page 50 for instructions. Also refer to “Removing and installing a CP8 control processor blade” on page 85 for details on firmware updates.

Note: Firmware downloads require that Ethernet connections be made to both CP blades. Procedures for loading firmware are described in the *Fabric OS Administrator’s Guide*.

Attention: A filler panel should be removed only when being replaced with a port blade or new filler panel. Any slot that is not occupied by a port blade should be occupied by a filler panel to ensure correct cooling of the chassis and protection from dust.

5. Remove the filler panel or port blade. Refer to “Removing a filler panel” on page 84 or “Removing a blade” on page 82.
6. Remove any mSFPs that are pre-installed in the new FC8-64 blade and set them aside for later installation. See “Removing and installing an mSFP optical transceiver” on page 106, paying particular attention to the notices to avoid damaging the mSFP pull tabs or mSFPs.
7. Follow the instructions for “Installing a blade” on page 83.

Note: The FC8-64 high density port blade cannot use the standard LC cables because the pitch between optics in the new mSFP transceiver is smaller than in standard SFPs. Patch cables and panels can be used to attach standard size cabling to the blade if necessary. Figure 12 on page 30 illustrates the mSFP to SFP patch cable. The mSFP transceivers are used only with the FC8-64 port blade. Narrower OM-3 LC cables are used to connect the FC8-64. These cables are offered by several major manufacturers. Contact your IBM representative for options regarding different cable and patch panel configurations to simplify cable management with higher density FC8-64 port blades.

8. Insert an OM-3 (narrow) cable into an mSFP, and then insert the mSFP/cable unit into a port. See “Removing and installing an mSFP optical transceiver” on page 106, paying particular attention to the notices to avoid damaging the mSFP pull tabs, mSFPs and cables.
9. Repeat step 8 for each port in the FC8-64 blade, proceeding in a systematic manner to avoid tangling the cables.
10. Group and route the cables. See “Managing cables” on page 46 for additional cabling instructions.

Attention: Do not route cables in front of the exhaust vent, which is located at the top on the port side of the chassis.

11. Verify the installation (see the appropriate section of Chapter 4, “Monitoring system components,” on page 53). For information about how to check the status of hardware components using the CLI, see the *Fabric OS Administrator’s Guide*, which is located on the product documentation CD.
12. Reinstall the chassis door. See “Removing and installing the chassis door” on page 79.

FC3890 - Installing an Extension Blade (FX8-24)

This feature can be installed while the SAN768B-2 is operational.

Attention: Follow these precautions for all procedures in this section to avoid damaging the port blades or chassis:

- Wear a grounded ESD strap when handling a port blade (see “ESD precautions” on page xix).
- Carefully remove the protective strip (if any) covering the blade connectors before installing any blades.
- Do not force the port blade installation. If the port blade does not slide in easily, ensure that it is correctly aligned inside the rail guides before continuing. Installing a port blade with incorrect alignment damages both the chassis and the replacement part.
- Hold the port blade by the edges of the metal pan. Do not use the ejectors to hold a port blade.
- Disassembling any part of a port blade voids the part warranty and regulatory certifications. There are no user-serviceable parts inside the port blade.

Time required

Less than 20 minutes.

Items required

- ESD (electrostatic discharge) grounding strap
- Workstation computer
- Port blade
- Phillips screwdriver
- Transceivers (as needed)
- Optical cables (as needed)

Procedures

Follow the links in the steps below to complete this installation.

1. Remove the chassis door. See “Removing and installing the chassis door” on page 79.
2. Verify that the blade is the correct part.
3. Verify which slot to install the blade. Port and application blades can be installed in any slot 1-4 and 9-12.
4. We recommend having the latest firmware version on the CP blade. The firmware version should match on both the active and the backup CP blades. If the firmware is not at the latest level, obtain new code from the code download website, and install it prior to installing the port blade. See “Fabric

OS firmware updates” on page 50 for instructions. Also refer to “Removing and installing a CP8 control processor blade” on page 85 for details on firmware updates.

Note: Firmware downloads require that Ethernet connections be made to both CP blades. Procedures for downloading and installing firmware are described in the *Fabric OS Administrator’s Guide*.

5. Remove the filler panel or existing port blade. Refer to “Removing a filler panel” on page 84 or “Removing a blade” on page 82.

Attention: A filler panel should be removed only when being replaced with a port blade or new filler panel. Any slot that is not occupied by a port blade should be occupied by a filler panel to ensure correct cooling of the chassis and protection from dust.

6. Install the port blade (“Installing a blade” on page 83). Remove the protective strip from the blade contacts (if any) before installing the blade.

7. Repeat steps 1-5 for additional blades, if any.

8. Install the transceivers (“Removing and installing transceivers” on page 104), and confirm the proper operation of the blade.

9. Install, group, and route the cables. See “Managing cables” on page 46 for additional cabling instructions.

Attention: Do not route cables in front of the exhaust vent, which is located at the top on the port side of the chassis.

10. Verify the installation (see the appropriate section of Chapter 4, “Monitoring system components,” on page 53). For information about how to check the status of hardware components using the CLI, see the *Fabric OS Administrator’s Guide*, or the *Fabric OS Command Reference*, which are located on the product documentation CD.
11. Reinstall the chassis door. See “Removing and installing the chassis door” on page 79.

FC3895 - Installing an Encryption Blade (FS8-18)

Attention: Thoroughly review “Planning for encryption (optional)” on page 47 prior to installing the FS8-18 encryption blade. You must also refer to the *Fabric OS Encryption Administrator’s Guide Supporting Tivoli Key Lifecycle Manager (TKLM) Environments* to successfully complete installation, configuration, and management of the encryption functionality.

This feature can be installed while the SAN768B-2 is operational.

Note: If three or more FS8-18 encryption blades are installed, four power supplies are required for redundancy.

Attention: Follow these precautions for all procedures in this section to avoid damaging the port blades or chassis:

- Wear a grounded ESD strap when handling a port blade (see “ESD precautions” on page xix).
- Carefully remove the protective strip (if any) covering the blade connectors before installing any blades.

- Do not force the port blade installation. If the port blade does not slide in easily, ensure that it is correctly aligned inside the rail guides before continuing. Installing a port blade with incorrect alignment damages both the chassis and the replacement part.
- Hold the port blade by the edges of the metal pan. Do not use the ejectors to hold a port blade.
- Disassembling any part of a port blade voids the part warranty and regulatory certifications. There are no user-serviceable parts inside the port blade.

Time required

Less than 20 minutes.

Items required

- ESD (electrostatic discharge) grounding strap
- Workstation computer
- Encryption blade
- Phillips screwdriver
- Transceivers (as needed)
- Optical cables (as needed)

Procedures

Follow the links in the steps below to complete this installation.

1. Verify that the blade is the correct part.
2. Verify which slot to install the blade. Port, application, and encryption blades can be installed in any slot 1-4 and 9-12. Up to four FS8-18 encryption blades can be installed in a single chassis.
3. We recommend having the latest firmware version on the CP blade. The firmware version should match on both the active and the backup CP blades. If the firmware is not at the latest level, obtain new code from the code download website, and install it prior to installing the port blade. See “Fabric OS firmware updates” on page 50 for instructions. Also refer to “Removing and installing a CP8 control processor blade” on page 85 for details on firmware updates.

Note: Firmware downloads require that Ethernet connections be made to both CP blades. Procedures for downloading and installing firmware are described in the *Fabric OS Administrator’s Guide*.

4. Remove the filler panel or port blade. Refer to “Removing and installing port, application, and encryption blades” on page 81 and “Removing and installing blade filler panels” on page 84.

Attention: A filler panel should be removed only when being replaced with a blade or new filler panel. Any slot that is not occupied by a blade should be occupied by a filler panel to ensure correct cooling of the chassis and protection from dust.

5. Install the encryption blade (“Installing a blade” on page 83). Remove the protective strip from the blade contacts (if any) before installing the blade.
6. Repeat steps 1-5 for additional blades, if any.
7. Install the transceivers (“Removing and installing transceivers” on page 104), and confirm the proper operation of the blade.

8. Install, group, and route the cables. See “Managing cables” on page 46 for additional cabling instructions.
Attention: Do not route cables in front of the exhaust vent, which is located at the top on the port side of the chassis.
9. Verify the installation. For information about how to check the status of hardware components using the CLI, see the *Fabric OS Administrator’s Guide*, which is located on the product documentation CD.
10. The FS8-18 encryption blade requires additional configuration to enable encryption. See “Configuring for encryption (optional)” on page 48 for an overview of those steps. Refer to the *Fabric OS Encryption Administrator’s Guide Supporting Tivoli Key Lifecycle Manager (TKLM) Environments* for more detailed information regarding encryption and TKLM key management.

Avoid double encryption

Encryption and decryption at the storage device level does not affect the encryption switch or blade capabilities, and does not cause problems with decrypting the data. However, double encryption adds the unnecessary need to manage two sets of encryption keys, increases the risk of losing data, may reduce performance, and does not add security.

FC7230 - Installing FIPS 140-2 Level 2 tamper proof seals

The majority of the seals in this feature can be installed while the SAN768B-2 is operational. However, there are several seals that may be difficult to apply to the chassis if the chassis is already installed in a cabinet. Plan the installation of the chassis and other features accordingly. Refer to the separate publication, *IBM System Storage FIPS 140-2 Security Seal Application Procedures (GA32-2220-00)*, for installation instructions of these seals for several different models. This publication is available through the IBM Support Portal www.ibm.com/supportportal and the IBM Publications Center www.ibm.com/shop/publications/order.

FC7871 - Installing a QSFP and inter-chassis license

This feature can be installed while the SAN768B-2 is operational.

Time required

Less than 10 minutes, not including installation of the ICL license or any needed configuration.

Items required

- QSFPs and four ICL cables
- FC 7871 (ICL license) is required for each chassis that you are connecting. Instructions for installation are included with that license feature.

Procedures

Attention: If ICL cables are not in use, rubber plugs must be inserted in the QSFPs.

Follow the links in the steps below to complete this installation.

1. Verify that the QSFP is the correct part: 99Y0377.

2. Verify with the customer that the ICL license is installed on each chassis to be connected. Enter the **licenseIdShow** command for each chassis. If required, install the ICL license, following the instructions included with the license.
3. Remove the chassis door (“Removing and installing the chassis door” on page 79).
4. Determine the cable routing and QSFP ports on the core switch blades that you will be using to connect the two chassis.
5. Remove the rubber plugs from the QSFP ports on the core blades that you will be connecting. Save the plugs for possible future use.
6. Install the two QSFPs and ICL cables (“Removing and replacing inter-chassis link (QSFP) cables” on page 107).
7. Install the chassis door (“Removing and installing the chassis door” on page 79).
8. Enable the inter-chassis links. See the **iclCfg** section in the *Fabric OS Command Reference* for CLI command options.
9. Verify the operation of the ICL (see Table 14 on page 108).
10. Refer to the *Fabric OS Administrator’s Guide* for the configuration procedure.

FC7873 - Installing a QSFP and Enterprise inter-chassis license

This feature can be used to connect up to nine 2499 fabric backbone chassis and can be installed while the SAN768B-2 is operational.

Time required

Depending on the complexity of the ICL configuration, installation can take from 20-60 minutes, not including installation of the ICL license or any needed configuration. Sample configurations are shown in “Possible ICL configurations” on page 110.

Items required

- QSFPs and four ICL cables for each chassis connection
- FC 7872 (ICL license for the 2499-416) or FC 7873 (ICL license for the 2499-816) is required for each chassis that you are connecting. Instructions for installation are included with that license feature.

Procedures

Attention: If ICL cables are not in use, rubber plugs must be inserted in the QSFPs.

Follow the links in the steps below to complete this installation.

1. Verify that the QSFP is the correct part: 99Y0377.
2. Verify with the customer that the ICL license is installed on each chassis to be connected. Enter the **licenseIdShow** command for each chassis. If required, install the ICL license, following the instructions included with the license.
3. Remove the chassis door (“Removing and installing the chassis door” on page 79).
4. Determine the cable routing and QSFP ports on the core switch blades that you will be using to connect the two chassis.
5. Remove the rubber plugs from the QSFP ports on the core blades that you will be connecting. Save the plugs for possible future use.

6. Install the two QSFPs and ICL cables (“Removing and replacing inter-chassis link (QSFP) cables” on page 107).
7. Install the chassis door (“Removing and installing the chassis door” on page 79).
8. Enable the inter-chassis links. See the **iclCfg** section in the *Fabric OS Command Reference* for CLI command options.
9. Verify the operation of the ICL (see Table 14 on page 108).

Appendix A. Product specifications

This appendix provides product specifications for the SAN768B-2 for the following characteristics:

- “General specifications”
- “System architecture”
- “System size and weight” on page 144
- “Facility requirements” on page 145
- “Power specifications” on page 145
- “Environmental requirements” on page 147
- “Fibre channel port specifications” on page 147
- “Data transmission ranges” on page 148

General specifications

Table 18 lists the general specifications for the SAN768B-2.

Table 18. General specifications

Configurable port types	F_Port, E_Port, EX_Port, M_Port, D_Port
System architecture	Nonblocking shared memory
System processor	FreeScale 8548, 1.2 GHz
ANSI Fibre Channel protocol	FC-PH (Fibre Channel Physical and Signalling Interface standard)
Classes of service	Class 2, Class 3, Class F (interswitch frames)
Fabric initialization	Complies with FC-SW 5.0
FC-IP (IP over Fibre Channel)	Complies with FC-IP 2.3 of the FCA profile
Port to port latency	Local switching - 800ns (add 400ns for E_Port to E_Port); Blade to blade - 2.4 microseconds (add 400ns for E_Port to E_Port)
Switching capacity	An aggregate switching capacity of 6.72 billion frames per second (for Class 2, Class 3, and Class F frames for a 384 port chassis)

System architecture

Table 19 lists the system architecture for the SAN768B-2.

Table 19. System architecture

Fibre Channel Ports	Up to 384 16 Gbps ports, universal (E_Port, F_Port, EX_Port, M_Port, D_Port).
Control Processor	Redundant (active/standby) control processor modules
Scalability	Full fabric architecture: 239 switches maximum

Table 19. System architecture (continued)

Performance	<p>2.125 Gbps line speed, full duplex. 4.25 Gbps line speed, full duplex. 8.50 Gbps line speed, full duplex. 10.51875 Gbps line speed, full duplex. 16.0 Gbps line speed, full duplex. Autosensing of 2, 4, 8, and 16 Gbps port speeds depending on SFPs used. Speed matching between 2, 4, 8, and 16 Gbps port speeds. 10 Gbps port speeds with dedicated SFPs.</p>
ISL Trunking	<p>Automatically uses up to 4 ports in a trunk group to form a 32 Gbps trunk. Can use up to 8 ports in a trunk group to form a 64 Gbps trunk.</p>
Aggregate bandwidth	<p>8.2 Tbps populated with eight FC16-48 port blades and using 32 ICL ports @ 64 Gbps).</p>
Switch latency	<p>FC8-64 blades: <2.1 msec any port to any port at 8 Gbps, cut-through routing. FC8-32E blade: <800 ns any port to any port, 2.4 msec blade to blade at 8 Gbps, cut-through routing. FC8-48E blade: <800 ns any port to any port, 2.4 msec blade to blade at 8 Gbps, cut-through routing. FC16-32 & FC16-48 blades: <800 ns any port to any port, 2.4 msec blade to blade at 16 Gbps, cut-through routing. For the FX8-24 blade - FC to FC: <2.1 msec any port to any port at 8 Gbps, cut-through routing.</p>
Maximum frame size	<p>2112-byte payload</p>
Frame buffers	<p>8000 per ASIC, with 5000 more that can be borrowed from neighboring ASIC if enabled.</p>
Port types	<p>FC8-64 supports these port types: F_Port, FL_Port, E_Port, Ex_Port, and M_Port FC8-32E supports these port types: F_Port, E_Port, Ex_Port, and M_Port. FC8-48E supports these port types: F_Port, E_Port, Ex_Port, and M_Port. FC16-32 and FC16-48 support these port types: F_Port, E_Port, Ex_Port, M_Port and D_Port. FS8-18 supports these port types: FL_Port, F_Port, E_Ports, EX_Port, and M_Port FX8-24 supports these port types: F_Port, FL_Port, E_Port, and Ex_Port on FC VE_Port on GbE Note: Self-discovery is based on switch type (U_Port) with an optional port type control.</p>
Data traffic types	<p>Fabric switches supporting unicast, multicast (255 groups), and broadcast</p>

Table 19. System architecture (continued)

Media types	<p>Attention: Use only transceivers that are supported for this product. Only transceivers purchased from IBM are supported. The use of transceivers that are not supported may cause data loss or cause the product to malfunction. For a listing of transceivers compatible with this product:</p> <ul style="list-style-type: none"> • Go to the IBM Support Portal www.ibm.com/supportportal. • In the Search field, enter b-type supported transceiver. • Alternatively, use this direct link: http://www-01.ibm.com/support/docview.wss?uid=ssg1S1004421.
Fabric services	<p>Advanced Performance Monitoring; Adaptive Networking (Ingress Rate Limiting, Traffic Isolation, QoS); auditing; BB credit recovery; Advanced Zoning (default zoning, port/WWN zoning, broadcast zoning); Dynamic Path Selection (DPS); End-to-End Performance monitoring; Extended Fabrics; Fabric Watch; FDMI; FICON CUP; Frame Redirection; FSPF; Integrated Routing; IPFC; ISL Trunking; Management Server; N_Port Trunking; NPIV; NTP v3; Port Fencing; Registered State Change Notification (RSCN); Reliable Commit Service (RCS); Simple Name Server (SNS); syslog; Top Talkers; Virtual Fabrics (Logical Switch, Logical Fabric)</p>
Inter-chassis linking (ICL/QSFP)	<p>Chassis-to-chassis linkage through connectors on the core switch blade (CR16-8)</p>

System size and weight

The weight of the SAN768B-2 can vary considerably depending on the combination of blades installed. Use Table 20 and Table 21 to determine the weight of the system with your combination of port and application blades.

Table 20. System sizes and weights

System size	Size or weight
Width	43.74 cm (17.22 in.)
Height	62.23 cm (24.5 in./14U)
Depth (without door)	61.29 cm (24.09 in.)
Depth (with door)	73.20 cm (28.82 in.)
SAN768B-2: 384-port configuration with eight FC16-48 port blades including two CP blades, 2 core switch blades, three blowers, four power supplies, and one cable management comb	101.3 kg (223.3 lb)
Empty chassis: <ul style="list-style-type: none"> • No blades • No CPs • No CRs • No power supplies • No fan assemblies 	37.3 kg (82.2 lb)

Table 21 lists the weights of the compatible blades and FRUs

Table 21. System FRU weights

FRU	Weight
CP blade (CP8)	3.0 kg (6.6 lb)
CR blade (CR16-8)	3.7 kg (8.1 lb)
FC8-32E port blade	2.8 kg (6.2 lb) without media
FC8-48E port blade	3.3 kg (7.3 lb) without media
FC16-32 port blade	2.8 kg (6.2 lb) without media
FC16-48 port blade	3.3 kg (7.3 lb) without media
FC8-64 port blade	3.36 kg (7.4 lb) without media
FS8-18 encryption blade	5.5 kg (12.0 lb) without media
FX8-24 extension blade	4.2 kg (9.2 lb) without media
Port card filler panel	1.5 kg (3.2 lb)
Power supply	2.45 kg (5.4 lb)
Blower assembly	5.73 kg (12.6 lb)
WWN bezel	0.3 kg (0.6 lb)
Cable management comb	0.45 kg (1.0 lb)
Chassis door	2.09 kg (4.6 lb.)

Facility requirements

The facility where the SAN768B-2 is in use must meet the following requirements to provide for correct operation:

- Adequate supply circuit, line fusing, and wire size, as specified by the electrical rating on the chassis nameplate
- An air flow of at least 595 cubic meters per hour (350 cubic feet per minute), available in the immediate vicinity of the SAN768B-2
- The power specifications listed in Table 22
- The environmental specifications listed in Table 24 on page 147
- If the SAN768B-2 will be installed in an EIA rack, ensure the equipment meets following requirements:
 - All equipment installed in the rack has a reliable branch circuit ground connection, and does not rely on a connection to a branch circuit, such as a power strip.
 - The rack is balanced and mechanically secured to provide stability in the event of an earthquake.
 - Additional equipment does not exceed the rack's weight limits.

Power specifications

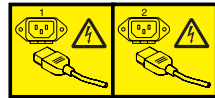

DANGER

Multiple power cords. The product might be equipped with multiple power cords. To remove all hazardous voltages, disconnect all power cords. (L003)

The power subsystem is a redundant +48 V dc power distribution system with a provision for up to four 2000-watt, 48V dc bulk power supplies. Bulk power supplies produce the intermediate distribution voltage in the distributed power system.

The power specifications listed in Table 22 are calculated for fully-loaded systems with four power supplies, three blower assemblies, eight FC16-48 or FC16-32 port blades, two CP8 blades, and two CR16-8 core blades with 32 640-Gbps QSFPs. The use of application and/or encryption blades will consume additional power.

Table 22. Power specifications

Specification	Value
Input voltage	Range: 85 - 264 VAC Auto-volt, Nominal: 100 to 240 VAC (auto-sensing)
Input frequency	Range: 47-63 Hz; Nominal: 50 - 60 Hz
Inrush current	Limited to 60A peak for any initial current surge or spike of 10ms or less at either cold or warm start . Any additional inrush current surges or spikes in the form of AC cycles or multiple AC cycles greater than 10ms, and less than 150ms, must not exceed 15A peak.

Table 22. Power specifications (continued)

Specification	Value
Power supply output (each)	Low line (85- 132 VAC), 1000W; High line (180 - 264 VAC), 2000W
System power consumption	AC power consumption is configuration specific. A system as described above consumes 1952W.

The base unit SAN768B-2 comes with two power supplies. The power requirements for a given configuration depend on which blades have been installed in the chassis. Table 23 shows the power draw for the blades that can be used in the SAN768B-2 chassis along with the power draw for the cooling fans. All numbers for the blades assume that the blade is fully populated with optical transceivers, including QSFPs for the core blades. All ports are Fibre Channel except where noted. You can calculate your power requirements by combining the power draws for the various blades and fan units in your configuration. While you may use fewer ports in a given blade, it is always safer to use the power requirement of a fully populated blade.

Table 23. Power demands per component

Blade or fan units	Maximum power draw (Watts)	Type of blade	Ports per blade	Number of blades permitted in chassis	Total ports per chassis
CP8	40	Control blade	NA	2	NA
CR16-8	240	Core blade	16 64 Gbps QSFP ports	2	32 quad ports (128 ports)
FC8-32E (8Gb)	140	Port blade	32 8 Gbps SFP+	up to 8	256
FC8-48E (8Gb)	160.4	Port blade	48 8 Gbps SFP+	up to 8	384
FC16-32 (16Gb)	140	Port blade	32 16 Gbps SFP+ (can use 8 Gbps SFP+)	up to 8	256
FC16-48 (16Gb)	160.4	Port blade	48 16 Gbps SFP+ (can use 8 Gbps SFP+)	up to 8	384
FC8-64 (8Gb)	126.4	Port blade	64 8Gbps SFP+	up to 8	512
FS8-18	235	Encryption blade	16 8 Gbps SFP+	up to 4	64
FX8-24	250	Extension blade	12 8 Gbps SFP+ 10 1 Gbps Ethernet 2 10 Gbps Ethernet	up to 4	48 8 Gbps 40 1 Gbps Ethernet 8 10 Gbps Ethernet
Fan unit	90	NA	NA	3 fans per chassis	NA

Environmental requirements

Table 24 lists the environmental operating ranges for the SAN768B-2. The requirements for non-operating conditions are also provided for acceptable storage and transportation environments.

CAUTION:

For CA residents only: IBM recommends installing this product in a room size of 2190 cubic feet (62 cubic meters) or larger at 0.4 ACH ventilation rate to reduce the concentrations of any chemicals emitted by the product.

Table 24. Environmental requirements

Condition	Acceptable range during operation	Acceptable range during nonoperation
Ambient temperature	0° to 40° C outside switch (32° to 104° F)	-25° to +70° C outside switch (-13° to 158° F)
Humidity	5% to 85% RH noncondensing, at 40° Celsius, with maximum gradient of 10% per hour	10% to 90% RH noncondensing, at 70° Celsius
Altitude	Up to 3 km (10,000 ft.) above sea level	0 to 12 km (40,000 ft.) above sea level
Shock	20G, 6ms duration, half-sine wave	33G, 11ms duration, half-sine wave
Vibration	0.5G p-p, 5-500 Hz at 1.0 octave/minute	2.0G p-p, 5-500 Hz at 1.0 octave/minute
Air flow	595 cu m/hr (350 cu ft/min)	None required.
Heat dissipation	2242 Watts or 7654 BTU/hr (384 port configuration)	Not applicable.

Note: The 0° to 40° Celsius range applies to the ambient air temperature at the air intake vents on the nonport side of the SAN768B-2. The temperature inside the system can be up to 75° Celsius during operation. If the internal temperature range exceeds the operating ranges of the components, the LEDs, error messages, and Fabric Watch alerts will indicate a problem. Use the **tempShow** command or Fabric Watch commands to view temperature status.

Fibre channel port specifications

The Fibre channel ports in the SAN768B-2 support full duplex link speeds at 2, 4, 8, 10, or 16 Gbps inbound and outbound, automatically negotiating to the highest common speed of all devices connected to the port.

The ports are compatible with optical SWL (short wavelength: approximately 850 nm), and optical LWL (long wavelength: approximately 1310 nm) SFP+s and mSFPs (FC8-64 only). The strength of the signal is determined by the type of SFP+ or mSFP. The mSFPs support only SWL.

QSFP ports are fixed speed 16 Gbps ports designed to be used with specialized quad (4x16) connections and cables. They support only SWL.

The ports are universal and self-configuring, capable of becoming F_Ports (fabric ports), FL_Ports (fabric loop enabled), or E_Ports (expansion ports).

The ports meet all required safety standards.

Data transmission ranges

Table 25 provides the data transmission ranges for different transceivers, cable types, and port speeds.

Note: There is no LWL or ELWL version of the mSFP or QSFP transceiver.

Table 25. Supported optics, speeds, cables, and distances

Transceiver type	Form factor	Speed	Multi-Mode Media Maximum Distance				Single Mode Media Maximum Distance
			62.5 microns (OM1)	50 microns (OM2)	50 microns (OM3)	50 microns (OM4)	9 microns
SWL	mSFP/SFP+	2 Gbps	150 m (492 ft.)	300 m (984 ft.)	500 m (1640 ft.)	N/A	N/A
	mSFP/SFP+	4 Gbps	70 m (229 ft.)	150 m (492 ft.)	380 m (1264 ft.)	400 m (1312 ft.)	N/A
	mSFP/SFP+	8 Gbps	21 m (68 ft.)	50 m (164 ft.)	150 m (492 ft.)	190 m (623 ft.)	N/A
	SFP+	10 Gbps	33 m (108 ft.)	82 m (269 ft.)	300 m (984 ft.)	550 m (1804 ft.)	N/A
	mSFP/SFP+	16 Gbps	15 m (49 ft.)	35 m (115 ft.)	100 m (328 ft.)	125 m (410 ft.)	N/A
	QSFP	4 x 16 Gbps	N/A	50 m (164 ft.)	N/A	N/A	N/A
LWL	SFP+	8 Gbps	N/A	N/A	N/A	N/A	10 km (6.2 mi.)
	SFP+	10 Gbps	N/A	N/A	N/A	N/A	10 km (6.2 mi)
	SFP+	16 Gbps	N/A	N/A	N/A	N/A	10 km (6.2 mi)
ELW	SFP+	2 Gbps	N/A	N/A	N/A	N/A	30 km (18.6 mi)
	SFP+	4 Gbps	N/A	N/A	N/A	N/A	30 km (18.6 mi)
	SFP+	8 Gbps	N/A	N/A	N/A	N/A	25 km (15.53 mi)

Power cords

Two power cords for connecting between the SAN768B-2 and the power distribution units on the 2109 C36 cabinet are shipped with the product. Two additional power cords are provided if the optional upgrade power supply feature is ordered (Feature Code 7880). See the *IBM TotalStorage SAN Cabinet 2109 Model C36 Installation and Service Guide* for information on connecting the cabinet to the facility power source. If the stand-alone feature is ordered for the SAN768B-2, then

you must also order the country-specific power cords. Contact your IBM representative for more information on these power cords.

Appendix B. Application blades

This appendix contains specification information about optional application blades

FS8-18 blade

The FS8-18 encryption blade is a high performance 16 port auto-sensing blade with data cryptographic (encryption/decryption) and data compression capabilities designed for enterprises to secure their data against theft or unauthorized use and to compress tape data for maximum utilization of tape media. The encryption blade is a network-based solution that secures data-at-rest for heterogeneous tape drives, disk array LUNs, and virtual tape libraries.

The FS8-18 blade provides the following major features:

- 16 auto-sensing F, FL, E, EX, and M ports at 8 Gbps FC ports
- 16 SFP media interfaces
- Encryption engines
- Key management/generation
- Key management with these hardware interfaces:
 - Two 1000Base copper type media interfaces
 - One smart card interface
- Security supervisor tamper detection and response capability
- CC (Common Criteria) EAL-3 compliance

FX8-24 blade

The FX8-24 blade has 12 external Fibre Channel (FC) SFP ports supporting the Fibre Channel Routing Services and 10 external 1 Gigabit Ethernet (GbE or GE) SFP ports supporting the Fibre Channel Over IP (FCIP) feature. There are also 2 licensable external 10 Gigabit Ethernet (10GbE or 10GE) SFP ports supporting FCIP. It operates with the Fabric Operating System and can communicate with another FX8-24 or a SAN06B-R for both Fibre Channel Routing Services and FCIP. The GbE ports on the FX8-24 are *not* compatible with the GbE ports on the FR4-18i blade or the SAN04B-R switch.

Note: The port diagram on the front panel of the blade uses the abbreviations GE for 1 GbE and 10GE for 10 GbE ports.

Attention: The 10 GbE SFPs used in the FX8-24 blade and the 10 Gbps FC SFP+s used in the FC16-32 and FC16-48 blades are NOT interchangeable.

The FX8-24 operates in one of three modes: 1) ten 1GbE ports, 2) ten 1GbE ports and one 10 GbE port, or 3) two 10 GbE ports depending on licensing and subsequent configuration of GbE port mode. If operating in 10GbE mode the other end of the circuit must also be an FX8-24 operating in either 10GbE mode or dual mode with the corresponding VE_ports in 10GbE mode. All GbE ports on the blade can be configured to work with either copper or optical SFPs.

The FX8-24 blade is intended as a platform for FCIP and Fibre Channel Routing Services. Refer to the *Fabric OS Administrator's Guide* for information on configuring these features. The FX8-24 blade provides the following hardware features:

- 12 autosensing FC ports with link speeds of 1, 2, 4 or 8 Gbps
- Ten GbE ports supporting FCIP with fixed link speed at 1 Gbps
- Two 10GbE ports (licensable) supporting FCIP with fixed link speed at 10 Gbps

The FX8-24 blade also provides the following functionality features:

- FCIP
- Compression (on FC frames before FCIP encapsulation)
- FC Routing (licensable)
- FCIP Trunking (licensable) with network-based failure recovery (failover only) and load balancing
- Multiple circuits per trunk
 - Four per trunk through the GbE ports
 - Ten per trunk through the 10 GbE ports
- SO-TCP with reorder resistance
- FastWrite over FCIP
- Tape pipelining over FCIP
- FICON XRC emulation and tape pipelining over FCIP (licensable)
- FICON with CUP Activation (licensable)
- Virtual E_ports
- FCIP QoS
- Support for 200 ms RTT (on a limited number of GbE ports)
- Adaptive Rate Limiting (licensable)
- TCP performance graphing in Web Tools
- FCIP Tunnels
 - A maximum of 10 FCIP Tunnels for all GbE ports
 - Four tunnels maximum per GbE port
 - Two 10 GbE ports can support up to ten FCIP tunnels each
 - Each FCIP tunnel is represented and managed as a virtual Fibre Channel E_Port
 - Fibre Channel Routing Services can be used over the FCIP link
 - Fabrics connected through FCIP merge if the ports are configured as VE_Ports, and do not merge if they are configured as VEX_Ports. If VE_Ports are used in a Fibre Channel Routing Services backbone fabric configuration, then the backbone fabric merges, but the EX_Port-attached edge fabrics do not merge. For more information refer to the *Fabric OS Administrator's Guide*.
- Up to three FC trunking groups. The three groups are defined as:
 - Trunk group 0: FC ports 0, 1
 - Trunk group 1: FC ports 6, 7
 - Trunk group 2: FC ports 2, 3, 4, 5, 8, 9, 10, 11

Appendix C. Diagnostics and troubleshooting

For information about troubleshooting the entire fabric, refer to the *Fabric OS Administrator's Guide*.

The SAN768B-2 includes a number of diagnostic tools to assist with troubleshooting, including LEDs on the hardware, commands that display current status, diagnostic tests for hardware and software, and error messages. In addition, a number of managing and monitoring features are available, such as Fabric Manager, Web Tools, Fabric Watch, and Advanced Performance Monitoring.

If the SAN768B-2 does not operate as expected, the following steps can be taken to diagnose the problem:

- Check the LEDs and refer to the LED tables (see Chapter 4, “Monitoring system components,” on page 53) for interpretation and recommended actions.
- Review the results of the last POST run by the SAN768B-2 (see “Interpreting POST and boot results” on page 154).
- Review the error logs (refer to the *Fabric OS System Error Messages Reference Manual* and the *Fabric OS Administrator's Guide* for more information).
- Review RASlog entries.
- Enter the **sensorShow** command to determine the status of the hardware components.
- Run diagnostic tests (see “Diagnostics” on page 155).
- Reboot the SAN768B-2 or power the entire chassis off (“Powering off the SAN768B-2” on page 51) and then back on (“Providing power to the SAN768B-2” on page 37).

If the problem is still unresolved after these steps, contact technical support.

This appendix provides the following information:

- “Obtaining chassis and component status”
- “Interpreting POST and boot results” on page 154
- “Diagnostics” on page 155
- “General troubleshooting” on page 155

Obtaining chassis and component status

The CLI commands listed in Table 26 on page 154 provide status and environmental information about the chassis and its components. These commands provide information only, and they do not interrupt traffic flow. For more information about these commands, refer to the *Fabric OS Command Reference*.

Table 26. Environmental status and maintenance commands

Command	Information Displayed
sensorShow	<ul style="list-style-type: none"> • Temperature readings for the port blades • Temperature readings for the CP blades • Status and RPM of all operational fans • Status of all operational power supplies
tempShow	<ul style="list-style-type: none"> • Temperature readings for the port blades • Temperature readings for the CP blades
psShow	Status of all operational power supplies
fanShow	Status and RPM of all operational fans
chassisShow	Serial number, time awake, and additional information about each component
slotShow	Slot occupancy
errShow errDump	System error log. Refer to the <i>Fabric OS Message Reference</i> for more information on the messages in this log.

Interpreting POST and boot results

The SAN768B-2 performs power on self test (POST) by default each time the system is powered on, rebooted, or reset. The system can be rebooted using the **reboot** (to reboot each CP individually), or **fastBoot** commands. The **fastBoot** command reboots the system without running POST. If the active CP blade is rebooted, it fails over to the standby CP blade.

POST

The system automatically performs POST each time it is powered on or reset.

To verify that POST has completed without error:

- Verify that all LEDs return to a normal state after POST completes (see Chapter 4, “Monitoring system components,” on page 53).
If one or more LEDs do not return to a normal state, and this is not due to the SAN768B-2 being set to beacon, refer to the relevant LED table to identify and correct the problem. For port blades, CP blades, and core switch blades, the **slotShow** command can be used to check the status of the slots. For information about turning beaconing on/off, refer to the *Fabric OS Administrator's Guide*.
- Verify that the switch prompt displays when POST completes.
If it does not display, POST was not successfully completed. Contact IBM for support.
- Review the system error log using the **errShow** or **errDump** commands.
- Any errors detected during POST are written to the system log, which is accessible through the **errShow** command. For information about error messages, refer to the *Fabric OS Message Reference*.

POST includes the following steps:

1. Preliminary POST diagnostics are run.
2. Operating system is initialized.
3. Hardware is initialized.

4. Diagnostic tests are run on several functions, including circuitry, port functionality, ability to send and receive frames, all aspects of memory, parity, statistics counters, and serialization.

Boot

In addition to POST, boot includes the following steps after POST is complete:

1. Universal port configuration is performed.
2. Links are initialized.
3. Fabric is analyzed. If any ports are connected to other switches, the SAN768B-2 participates in a fabric configuration.
4. The SAN768B-2 obtains a domain ID and assigns port addresses.
5. Unicast routing tables are constructed.
6. Normal port operation is enabled.

Diagnostics

Diagnostic tests are automatically run during POST to check the status of the system. Any error messages generated during POST are sent to the error logs and to the serial console, if connected.

Diagnostic tests can also be run manually to test and troubleshoot the hardware and the firmware, including internal connections and circuitry, transceivers, and port cables. However, diagnostic tests are generally intended for use by support personnel.

Note: Diagnostic error messages do not necessarily indicate that the system requires maintenance.

Each diagnostic test can be implemented by entering the related command through a Telnet or serial session. For a list of diagnostic tests and commands, refer to the *Fabric OS Administrator's Guide*.

All diagnostic tests are run at link speeds of 1, 2, 4, and 8 Gb/sec. They might temporarily lock the transmit and receive speeds to a specific speed. Some diagnostic tests require interconnecting the ports to each other or using loopback plugs. If ports are interconnected, the media (cables and transceivers) at each end of the connection must be of the same type. For example, short wavelength media must be connected to short wavelength media, and likewise with long wavelength media and copper media.

For more information about diagnostic tests and how to run them, refer to the *Fabric OS Administrator's Guide* and the *Fabric OS Command Reference*. For information about diagnostic error messages (**errShow** or **errDump**), refer to the *Fabric OS Troubleshooting and Diagnostics Guide*.

General troubleshooting

Table 27 provides a list of issues, possible causes, and recommended actions.

Table 27. Troubleshooting

Issue	Possible Cause	Recommended Action
Entire chassis powers off automatically.	Power supplies are inadequate to support the installed components.	Add an additional power supply.

Table 27. Troubleshooting (continued)

Several or all components are not operating.	One or more power cables may not be connected to a live source.	Ensure that all power cables are connected to live outlets.
	One or more AC power supplies may be off	Ensure that all switches on the AC power supplies are turned on. (AC switches light up green when on).
Serial connection is faulty or serial port logs have incorrect or missing information.	Serial cable is not connected correctly.	Ensure that the cable is firmly connected to workstation computer and to the SAN768B-2.
	Terminal emulator application parameters are not set correctly.	Ensure that the terminal emulator application is configured as follows: 9600 bits per second, 8 databits, no parity, 1 stop bit, no flow control.
	Serial port might be incompatible (only RS-232 is supported).	Ensure that the SAN768B-2 is connected to an RS-232 port. RS-423 serial ports might experience difficulties due to corner-case incompatibilities of the standards.
	Pins on the serial cable or serial port might be damaged.	Remove the cable and inspect the pins on the cable and in the serial port. Do not reinstall if the pins on either component have any visible damage, as this could damage the pins on the other component. Replace components as required.
CP Ethernet link speed is different than expected or a link cannot be established.	There might be a conflict with the CP Ethernet link speed negotiation set up by the network.	Specify the CP Ethernet link speed by entering the ifModeSet command.
Configuration data is inaccurate or cannot be accessed.	Chassis was powered off/on while the WWN card was uninstalled or failed.	Install an operational WWN card and power the system off/on again.
	The SAN768B-2 was rebooted while the WWN card was uninstalled or failed.	
Initial set up results in IP address/Domain ID conflict.	The SAN768B-2 was connected to the fabric before being configured.	Refer to Chapter 3, "Starting and configuring the SAN768B-2," on page 35 and the <i>Fabric OS Administrator's Guide</i> for configuration information.
LEDs on one or more components are changing rapidly or do not indicate a healthy state.	The SAN768B-2 might be booting or running POST.	Verify that boot and POST are complete. The SAN768B-2 requires a minimum of 3 minutes, usually, after power-on to complete POST.
	Beaconing might be on for the entire SAN768B-2 or for individual components.	Determine whether beaconing is on by entering the switchShow command and determine whether switch beaconing or blade beaconing is on.
	Individual components might have failed.	Refer to the LED tables in Chapter 4, "Monitoring system components," on page 53 for interpretation and recommended actions.
	Pins on the components might be damaged.	Remove component from chassis and inspect pins on component and inside chassis. Do not reinstall if pins on either component are visibly damaged, as this could damage pins on other component. Replace parts as required.

Table 27. Troubleshooting (continued)

None of the LEDs on an individual component are on.	Component might not be seated correctly.	Ensure that the SAN768B-2 has power and component is firmly seated. If problem continues, run the sensorShow command to determine component status. If component is a CP blade or port blade, enter the slotShow command to determine status.
	Component might have failed.	Replace component as necessary.
CP blades are failing over frequently.	A third-party application has a memory leak.	Check application for memory leaks.
	There is excessive serial port activity.	Ensure that serial port activity remains below specified amount.
	CP blade is attached to an Ethernet with high traffic loads.	Ensure that Ethernet traffic remains below specified amount.
	Chassis is overheated.	Enter the tempShow and sensorShow commands to check internal temperature. If components are overheating, shut down the port blades as necessary to return the temperature to operating range.
One or more port or application blades have either shut down or failed POST as indicated by the error log.	Blades might be overheated.	Enter the sensorShow command to check the internal temperature readings. If components are overheating, shut down the port blades as necessary to return the temperature readings to the operating ranges.
	Blades might be faulty.	Enter the slotShow command to determine status. For more information, enter the diagDisablePost command; then, the slotPowerOff [slot number] and slotPowerOn [slot number] commands. Resolve the source of the problem or replace the blade as required.
	Pins on the blade or on the backplane (inside the slot) might be damaged.	Remove blade from chassis and inspect pins on blade and on backplane inside slot. Do not reinstall if pins on either component are visibly damaged, as this could damage pins on other component. Replace components as required.
An individual component is not operating as expected.	Component may not have power or may not be firmly seated.	Ensure component is receiving power (power LED should be on) and component is firmly seated.
	Pins on the component or the backplane might be damaged.	Remove component from chassis and inspect pins on blade and inside chassis. Do not reinstall if pins on either component are visibly damaged, as this could damage pins on other component. Replace parts as required.
	The component might have failed.	Enter the tempShow and sensorShow commands to determine component status. If component is a CP blade or port blade, enter the slotShow command to determine the status. Replace the component as necessary.

Link troubleshooting

IBM SAN b-type directors and switches use the latest high bandwidth Fibre Channel technology and auto-negotiate to 16 Gbps, 8 Gbps, 4 Gbps, or 2 Gbps based on the link data rate capability of the attached transceiver and the speed supported by the switches and directors. Negotiation to 1 Gbps is not supported

unless 4 Gbps FC transceivers are used. As the 8 and 16 Gbps channel is more sensitive to the condition of the existing multimode and single mode cable plant, it is very important to minimize connector reflections and maintain an acceptable link loss budget.

This section provides link troubleshooting advice on fault isolation and provides guidance in the following areas:

- Dust and dirt contamination
- Link loss
- Attenuation on LWL connections

Fault isolation

Since a job loss issue can be caused by a variety of problems, it is important to employ a systematic fault isolation process to remedy the issue. Note that job losses do not necessarily result from link errors. They may also be due to:

- Configuration issues
- Networking overload
- Failures on storage device, switch, or server

Assume for these procedures that the observed errors originate from link errors and are not the result of configuration issues, network overload or network equipment failures.

Whenever CRC errors are discovered on a particular link, it is easy to jump to the conclusion that the link is causing the network issue. This might not be the case. Since CRC errors are just symptoms of a link issue, we need to trace the propagated error to where it originated.

Figure 47 shows a simplified network involving a server, a switch, and a storage device. In this example, assume that the server experienced an error at port 1. This observable error can potentially originate from links 1, 2, 3 or 4 and/or SFP 1, 2, 3 or 4.

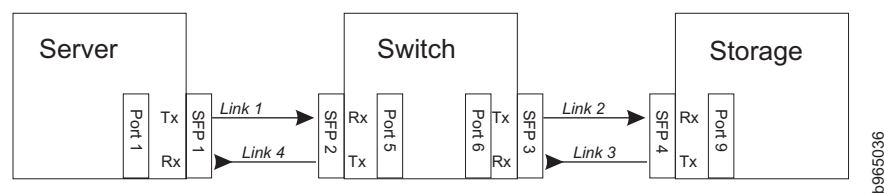

Figure 47. Identifying the origin of failure

To determine the original failing link, the observable CRC error needs to be tracked back to the first occurrence of the CRC error. By following this process, it is discovered in this example that CRC errors observed in link 4 were propagated from link 3, which in turn originated from link 2.

Once the original failing link (link 2) has been determined, the two connecting ports of that link need to be checked for the following errors:

- Encoder errors
- Disparity errors
- Invalid transmission words

The port that displays any of the above errors is the cause of the link issue, which can be caused by dust or dirt in the connectors or fiber, an insufficient link loss budget, and/or incompatible SFPs.

Dust, dirt, or other contaminants

One of the most common optical link problems is caused by dust, dirt, or oil in the connectors and fiber. 8 and 16 Gbps links are more prone to such issues while lower link data rates, such as 1, 2, or 4 Gbps may be unaffected.

Once the failing port has been identified by following the above fault isolation process, the receive power of the transceiver sitting in that port needs to be determined. An abnormally low receive power usually means that the physical link is dirty.

The receive power can be checked by querying the SFP diagnostics data via the command line interface. This information will provide a rough gauge whether the receive power is abnormally lower than the minimum receive specification of the transceiver. It is also prudent to compare this receive power with those of neighboring transceivers.

For better accuracy, it is advisable to use a power meter to measure the actual receive power of the link. If you are experiencing excessive bit errors and the receive power of the transceiver is abnormally low, it is recommended that you:

- Re-seat the transceivers for the failing link
- Clean the connector and optical fiber

Most link issues are solved by completing these steps.

Best practices for minimizing link loss

The "link margin" or the "power budget" of the link is a measure of signal power gain or loss expressed in decibels (dB). Maintaining a healthy link budget is critical to establishing a reliable and stable network.

Follow these best practices for minimizing link loss:

- Stay well within the maximum cable distance calculated for the link.
- Apply typical or worst-case values during loss calculations.
- Use the highest grade cabling components for the application to be supported.
- Match the cable type with the wavelength, bandwidth, and distance to be supported; do not mix cable types within a link.
- Inspect loss ratings of all cabling components during the selection process.
- Record loss measurements for horizontal and vertical cable runs during installation.
- Become familiar with how to quickly determine the link budget and link loss of selected sections of the cabling.
- Account for power loss associated with future repairs and expansion.
- Do not stress the cables.
- Prototype a link with anticipated maximum cable distance and selected components—and then take measurements to calculate the actual link loss

Attenuation on LWL connections

In the datacenter environment, there may be 8 Gbps or 4 Gbps LWL transceivers that are connected to 2 Gbps LWL transceivers using single-mode fiber over short

distances. Such connections need to be optically engineered because there is a possibility that the transmit power of the 8 Gbps / 4 Gbps LWL transceivers may saturate the receiver of 2 Gbps LWL transceivers and cause CRC errors.

Attention: This discussion does not apply to 16 Gbps transceivers since connections between 16 Gbps and 2 Gbps transceivers is *not* supported.

Refer to Table 28 for the typical specifications of maximum transmit and receive power of LWL transceivers. This information is also available in the information technology industry standard "Fibre Channel – Physical Interface-4 (FC-PI-4)" document.

Table 28. Specifications of LWL 10km transceivers

LWL SFP/SFP+	2GFC	4GFC	8GFC
Power, Tx (max) dB	-3	-1	+0.5
Power, Rx (max) dB	0 or -3 ¹	N/A	N/A
¹ The maximum receive power specifications of some 2 Gbps LWL 10km transceivers can vary from 0dB to -3dB. However, most 2 Gbps 10km transceivers specify a maximum receive power of 0dB.			

It is important to check the maximum receive power of the 2 Gbps LWL transceiver in the manufacturer's datasheet.

Without taking into account connector and fiber losses, the transmit power of 8 Gbps / 4 Gbps LWL transceivers may be observed to overdrive the -3dB maximum receive power of 2 Gbps LWL transceivers. If the maximum receive power of the 2 Gbps LWL transceiver is 0dB, a 4 Gbps LWL transceiver with a -1dB transmit power will not overdrive the 2 Gbps transceiver. Although some 8 Gbps LWL transceivers may reduce their transmit power to 4 Gbps levels, this may still overdrive a 2 Gbps LWL transceiver.

Best Practice for LWL connections – Optically engineer a long-distance connection

It is always a good practice to optically engineer a long-distance connection. Most link issues caused by SFP incompatibility can be solved either by use of 4 Gbps LWL transceivers or use of 8 Gbps LWL transceivers that employ rate select.

2G LWL SFP maximum receive power

The IBM SAN b-type 8 Gbps and 16 Gbps directors and switches use the latest high bandwidth Fibre Channel technology and auto-negotiate to 16 Gbps, 8 Gbps, 4 Gbps, or 2 Gbps based on the link data rate capability of the attached transceiver. Negotiation to 1 Gbps is *not* supported. Since 8 and 16 Gbps equipment is more sensitive, the existing cable plant may require additional attention to cable care after upgrading from 2 or 4 Gbps fibre. In a few cases, the Tx power of the switch can be higher than the connected equipment. In nearly all of those cases, there is enough attenuation in the existing cable plant so as not to require additional attenuation. The common 2 Gbps SFP Rx maximum power levels are listed in Table 29 and can be used as a quick method to relieve concerns of over saturation.

Table 29. Maximum receive power of 2 Gbps LWL SFPs

Vendor	Part number	Description	Max Receive Power (dB)
Avago	AFCT-57M5ATPZ	2 Gbps 10 km SFP	-3 dB
Finisar	FTFL1319P1xTL	2 Gbps 10 km SFP	0 dB

Table 29. Maximum receive power of 2 Gbps LWL SFPs (continued)

Vendor	Part number	Description	Max Receive Power (dB)
Finisar	FTRJ1319P1xTL	2 Gbps 10 km SFP	0 dB
JDSU	JSH-12L1DD1	2 Gbps 10 km SFP	1 dB
Hitachi Cable	HTR6517	2 Gbps 10 km SFP	-3 dB
Optoway	SPS-9110FG	2 Gbps 10 km SFP	-3 dB
Optoway	SPS-9110AFG	2 Gbps 10 km SFP	-3 dB
JDSU	JSH-21L3AR3	2 Gbps 10 km SFP	1 dB
E20	ES212-LP3TA	2 Gbps 10 km SFP	-3 dB

Appendix D. Tuning the system

Some sensitive applications may experience performance impact if the bit-error-rate is high enough even though it still adheres to Fibre Channel specifications. The probability of performance impact due to this condition is extremely low. In these cases tuning may be required to optimize your application performance.

Tuning your system in the manner described in this section is *only* required if one of the following blades installed in your chassis and are experiencing issues on those blades:

- FC 8 Gbps, 64-port switch blade (FC 3864)
- FC 8 Gbps Encryption blade (FC 3895)
- FC 8 Gbps FCIP Extension Blade (FC 3890/FC 3891)

If your system only contains FC 16 Gbps port blades (FC 3648 or FC 3632) or Enhanced FC 8 Gbps port blades (FC 3649 or FC3633) then the steps outlined in this section are *not* applicable. If you are experiencing issues in your system with only these blades then try other Troubleshooting recommendations or call IBM Support for additional help.

Identifying whether you need to tune your system

To identify whether you need to tune your system begin by reviewing the chassis error log for C2-1010 or C3-1010 events. The Cx-1010 error messages triggers when a certain number of errors are detected on a port over a certain period of time. This counter includes CRC and other bit errors for internal ports.

The Cx-1010 event message has the following format:

```
Message <timestamp>, [Cx-1010], <sequence number>, Slot <CP Slot#>, CRITICAL,  
<system name>, S<slot number>, C<chip index>: Internal monitoring has identified  
suspect hardware, blade may need to be reset or replaced: fault1:<fault1_cnt>,  
fault2:<fault2_cnt> th2:0x<threshold_used>.
```

An example of finding a C2-1010 message using the **errdump** command on an IBM SAN768B-2 is shown below:

```
errdump -a | grep C2-1010  
2013/03/05-01:01:01:307873: [C2-1010], 2/0, Slot6, CRITICAL,, S3,C1:  
Internal monitoring has identified suspect hardware, blade may need to  
be reset or replaced: faul:0x10, fau2:0x02 th2:0x0
```

Identify the port blade that is having an issue in the error message by noting the S<slot number>. In the above example, the S<slot number> is S3, meaning that the port blade in slot 3 potentially has the issue.

Note: In a SAN768B-2 chassis slots 1-4 and 9-12 are port blades while slots 5 and 8 are core blades. In a SAN384B-2 chassis slots 1-2 and slots 7-8 are port blades while slots 3 and 6 are core blades. The S<slot number> value may indicate an error being detected either on a port blade or core blade.

If the error found is a C3-1010 message that is originating from a slot that has a FC 16 Gbps port blade (FC 3648 or FC 3632) or Enhanced FC 8 Gbps port blade (FC

3649 or FC3633) then you *should not* continue the tuning guidelines outlined in this section. Try other troubleshooting options or call IBM Support for additional help.

If the error found is a C2-1010 message or a C3-1010 message originating from a core blade, then check to see whether the bit errors that are occurring are those for which tuning can help with. This can be done by looking for C2-5825 or C3-5825 event messages that triggers when a CRC error with good EOF (crc_good_eof) is detected on an internal port.

Note: Cx-5825 events can only be viewed by logging in as the root account to view additional error logging.

The Cx-5825 event message has the following format:

```
Message <timestamp>, [Cx-5825], <sequence-number>,, WARNING, <system-name>,
S<slot number>,B<blade port number>: Detect CRC error with good EOF on C-port:
<blade port number> count <error count>
```

An example of finding a C2-5825 message using the **errdumpall** command is shown below:

```
errdumpall | grep C2-5825
2013/03/05-01:01:01:307873, [C2-5825], 2/0, SLOT 6 | CHASSIS, WARNING,
testsystem, S3,B-1: Detect CRC error with good EOF on C-port(15)
count(21300), OID:0x4332800f, ...

2013/03/05-02:02:01:307873, [C2-5825], 2/0, SLOT 6 | CHASSIS, WARNING,
testsystem, S3,B-1: Detect CRC error with good EOF on C-port(15)
count(21324), OID:0x4332800f, ...
```

Identify the slot that is having an issue in the error message by noting the S<slot number>, B<blade port number>. In the above example, the S<slot number> is S3, meaning that the port blade in slot 3 potentially has the issue, and blade port number is 1. The error message includes a timestamp with the format <year>/<month>/<date>-<hh>:<mm>:<ss>:<ms>. The error message also includes a count(#) field where # is a count of the number of errors logged since the counter started.

The error message for Cx-5825 should be polled over a period of time while traffic is running to see if it is incrementing for a particular slot and blade port number. This should ideally be done over the interval when the application is experiencing performance problems in order to see if the issue is related to internal CRC errors with good EOF.

1. If the Cx-5825 counters are not incrementing for any specific slot and blade port number then this indicates the Cx-1010 error message was logged for other types of errors for which tuning may not help. Contact IBM Support for further assistance.
2. If the Cx-5825 counters are incrementing for a specific slot and blade port number then tuning for the internal links may help resolve the issue. Make a note of which slot number is experiencing issues.

In the C2-5825 error message examples above, the timestamps for the first error message is 2013/03/05-01:01:01:307873 and 2013/03/05-02:02:01:307873 for the second error message. Approximately 60 minutes elapsed between when the first and second messages were logged. The count of the first error message is 21300 and 21324 for the second error message. This indicates approximately 24 CRC errors with good EOF were detected over this 60 minute period.

Note: Some CRC errors may be acceptable without impact to application performance. The recommended threshold for tuning is if there are about 100 CRC with good EOF errors per 24 hours. If the error rate is extreme such as 50 errors per minute or 100 per hour, call IBM Support for additional troubleshooting.

Before tuning

Additional SAN384B-2 and SAN768B-2 tuning must be performed by support. Prior to calling support, the following steps should be followed.

Step #1 – Power cycle the Core blade

If the problem was found on a core blade attempt to power cycle the core blade. If the problem was found on a port blade power cycle each core blade one at a time. Make sure that the first core blade that is power cycled is fully operational before power cycling the second core blade. You can also wait to check if issues recur before power cycling the second core blade.

The recommended method of power cycling the core blade is by sliding the black slider switch with the power symbol down to the off position to initiate a hot-swap request. Make sure that the power LED on the core blade has gone off for one minute and then re-slide the black slider switch back up to the on position.

If physical access to the box is impossible the core blades can be power cycled using a CLI command. However, some frame loss can be expected when using the CLI commands to power cycle the core blade.

The following CLI commands can be used to power cycle the core blade (caution: frame drops can occur):

```
slotpoweroff -d626 <slot #>
slotpoweron -d626 <slot #>
```

Note: The `slotpoweroff -d626 <slot #>` and `slotpoweron -d626 <slot #>` commands require root permissions.

To check whether a core blade is fully operational you can use the `slotshow` command and verify that the status of the core blade displays as “ENABLED”. An example of power cycling a core blade in slot 3 in an IBM SAN384B-2 is shown below.

```
SAN384B-2:FID128:admin> slotshow
```

Slot	Blade Type	ID	Status
1	AP BLADE	75	ENABLED
2	UNKNOWN		VACANT
3	CORE BLADE	99	ENABLED
4	CP BLADE	50	ENABLED
5	CP BLADE	50	ENABLED
6	CORE BLADE	99	ENABLED
7	UNKNOWN		VACANT
8	SW BLADE	96	ENABLED

```
SAN384B-2:FID128:admin> slotpoweroff -d626 3
```

```
Slot 3 is being powered off
```

```
SAN384-2:FID128:admin> slotshow
```

Slot	Blade Type	ID	Status
------	------------	----	--------

```

1    AP BLADE    75    ENABLED
2    UNKNOWN
3    CORE BLADE  99    INSERTED, NOT POWERED ON
4    CP BLADE    50    ENABLED
5    CP BLADE    50    ENABLED
6    CORE BLADE  99    ENABLED
7    UNKNOWN
8    SW BLADE    96    ENABLED

```

```
SAN384B-2:FID128:admin> slotpoweron -d626 3
```

```
Powering on slot 3
```

```
SAN384B-2:FID128:admin> slotshow
```

```

Slot  Blade Type  ID  Status
-----
1     AP BLADE    75  ENABLED
2     UNKNOWN
3     CORE BLADE  99  POWERING UP
4     CP BLADE    50  ENABLED
5     CP BLADE    50  ENABLED
6     CORE BLADE  99  ENABLED
7     UNKNOWN
8     SW BLADE    96  ENABLED

```

```
SAN384B-2:FID128:admin> slotshow
```

```

Slot  Blade Type  ID  Status
-----
1     AP BLADE    75  ENABLED
2     UNKNOWN
3     CORE BLADE  99  DIAG RUNNING POST1
4     CP BLADE    50  ENABLED
5     CP BLADE    50  ENABLED
6     CORE BLADE  99  ENABLED
7     UNKNOWN
8     SW BLADE    96  ENABLED

```

```
SAN384B-2:FID128:admin> slotshow
```

```

Slot  Blade Type  ID  Status
-----
1     AP BLADE    75  ENABLED
2     UNKNOWN
3     CORE BLADE  99  ENABLED
4     CP BLADE    50  ENABLED
5     CP BLADE    50  ENABLED
6     CORE BLADE  99  ENABLED
7     UNKNOWN
8     SW BLADE    96  ENABLED

```

Check to see if power cycling the core blade resolves the issue by seeing if application performance has improved and/or Cx-1010/Cx-5825 errors continue to be logged over a 24 hour period. If power cycling the core blades has not resolved your issues, proceed to step #2.

Step #2 – Power cycle the port blade

If power cycling the core blade(s) do not help resolve the issue and the error messages originated from a port blade then try power cycling the port blade.

Attention: All connected devices on the port blade will be disconnected during the power cycle. If you cannot risk disruption to the connected devices on the port blade, proceed to Step #3.

To power cycle the port blade, use the following command:

```
slotpoweroff <slot #>  
slotpoweron <slot #>
```

An example of power cycling a port blade in slot 8 in an IBM SAN384B-2 is shown below.

```
SAN384B-2:FID128:admin> slotpoweroff 8
```

Slot 8 is being powered off

```
SAN384B-2:FID128:admin> slotshow
```

Slot	Blade Type	ID	Status
1	AP BLADE	75	ENABLED
2	UNKNOWN		VACANT
3	CORE BLADE	99	ENABLED
4	CP BLADE	50	ENABLED
5	CP BLADE	50	ENABLED
6	CORE BLADE	99	ENABLED
7	UNKNOWN		VACANT
8	SW BLADE	96	INSERTED, NOT POWERED ON

```
SAN384B-2:FID128:admin> slotpoweron 8
```

Powering on slot 8

```
SAN384B-2:FID128:admin> slotshow
```

Slot	Blade Type	ID	Status
1	AP BLADE	75	ENABLED
2	UNKNOWN		VACANT
3	CORE BLADE	99	ENABLED
4	CP BLADE	50	ENABLED
5	CP BLADE	50	ENABLED
6	CORE BLADE	99	ENABLED
7	UNKNOWN		VACANT
8	SW BLADE	96	POWERING UP

```
SAN384B-2:FID128:admin> slotshow
```

```
SAN384B-2:FID128:admin> slotshow
```

Slot	Blade Type	ID	Status
1	AP BLADE	75	ENABLED
2	UNKNOWN		VACANT
3	CORE BLADE	99	ENABLED
4	CP BLADE	50	ENABLED
5	CP BLADE	50	ENABLED
6	CORE BLADE	99	ENABLED
7	UNKNOWN		VACANT
8	SW BLADE	96	ENABLED

Check to see if power cycling the port blade resolves the issue by seeing if application performance has improved and/or Cx-1010/Cx-5825 errors continue to be logged. If power cycling the port core blade has not resolved your issues, proceed to step #3.

Step #3 – Contact IBM Support

If power cycling the core or port blades does not resolve the issue, collect a **supportsave** and contact IBM Support.

Appendix E. Blade port numbering

The illustrations in this appendix show the port numbering for the different SAN768B-2 blades. See “Port numbering” on page 28 for details on the port numbering pattern for the different blades.

- Figure 48 on page 170 shows a CR16-8 core blade
- Figure 49 on page 172 shows an FC16-32 port blade
- Figure 50 on page 173 shows an FC16-48 port blade
- Figure 51 on page 174 shows an FC8-32E port blade
- Figure 52 on page 175 shows an FC8-48E port blade
- Figure 53 on page 176 shows an FC8-64 port blade
- Figure 54 on page 177 shows an FS8-18 encryption blade
- Figure 55 on page 178 shows an FX8-24 extension blade

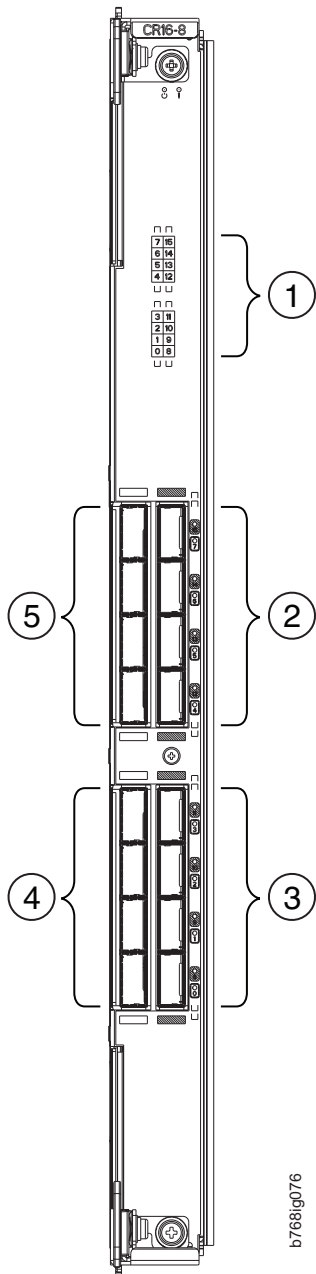

Figure 48. CR16-8 core blade

- | | | | |
|----------|----------------------------------|----------|--------------------------------|
| 1 | Port map | 4 | QSFP ports 0-3 (bottom to top) |
| 2 | QSFP ports 12-15 (bottom to top) | 5 | QSFP ports 4-7 (bottom to top) |
| 3 | QSFP ports 8-11 (bottom to top) | | |

Table 30 on page 171 shows the mappings from the numbered ports on the face of the core blade to the port mappings as shown by the **slotShow** command. Each external port maps to four actual ports.

Table 30. External port to **slotShow** port mapping for CR16-8 core blades

External port number	slotShow port numbers	External port number	slotShow port numbers
0	0-3	8	32-35
1	4-7	9	36-39
2	8-11	10	40-43
3	12-15	11	44-47
4	16-19	12	48-51
5	20-23	13	52-55
6	24-27	14	56-59
7	28-31	15	60-63

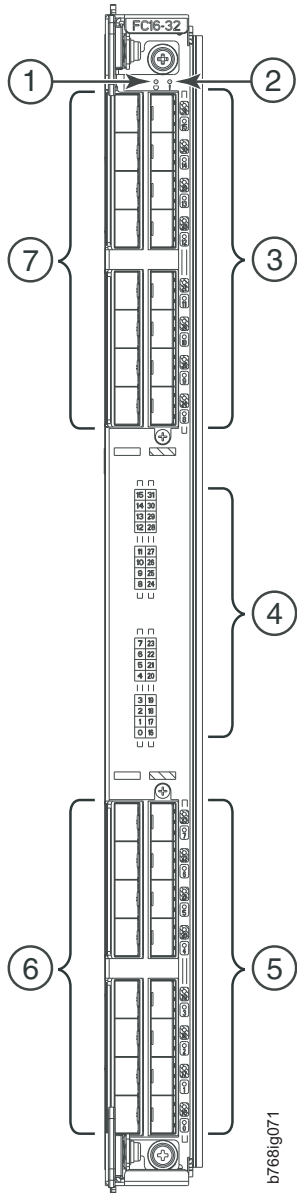

Figure 49. FC16-32 port blade

- | | |
|---|---|
| <ul style="list-style-type: none"> 1 Power LED 2 Status LED | <ul style="list-style-type: none"> 3 FC ports 16-31 (bottom to top) 4 FC ports 0-15 (bottom to top) |
|---|---|

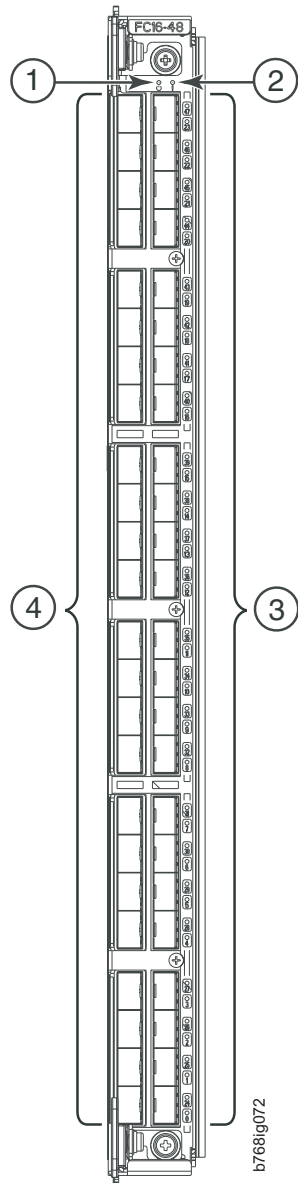
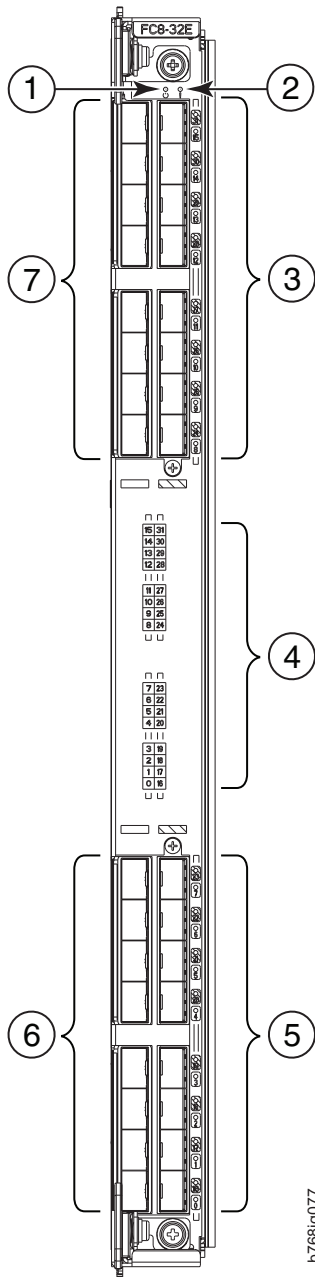

Figure 50. FC16-48 port blade

- | | |
|--|--|
| <p>1 Power LED</p> <p>2 Status LED</p> | <p>3 FC ports 24-47 (bottom to top)</p> <p>4 FC ports 0-23 (bottom to top)</p> |
|--|--|



b7681g077

Figure 51. FC8-32E port blade

- | | | | |
|----------|-----------------------------|----------|----------------|
| 1 | Power LED | 5 | FC ports 16-23 |
| 2 | Status LED | 6 | FC ports 0-7 |
| 3 | FC ports 24-31 | 7 | FC ports 8-15 |
| 4 | Port and trunking group map | | |

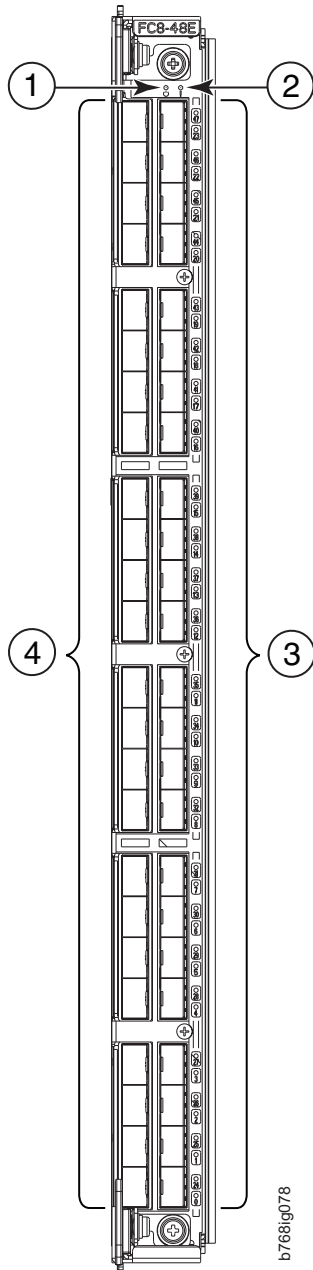

Figure 52. FC8-48E port blade

- | | | | |
|----------|------------|----------|----------------|
| 1 | Power LED | 3 | FC ports 24-47 |
| 2 | Status LED | 4 | FC ports 0-23 |

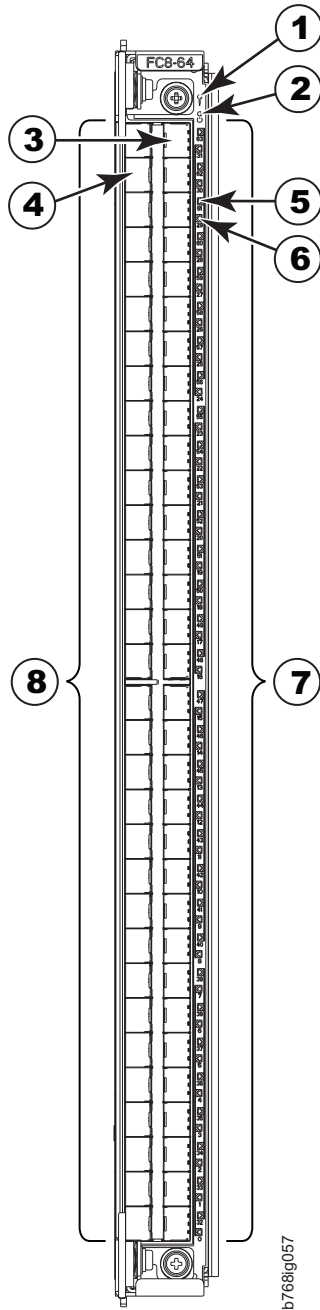

Figure 53. FC8-64 port blade

- | | | | |
|----------|------------|----------|--------------------------------|
| 1 | Power LED | 5 | Port 61 LED |
| 2 | Status LED | 6 | Port 29 LED |
| 3 | Port 63 | 7 | FC ports 32-63 (bottom to top) |
| 4 | Port 30 | 8 | FC ports 0-31 (bottom to top) |

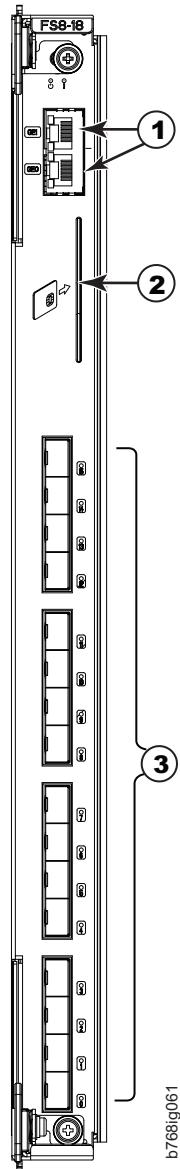

Figure 54. FS8-18 encryption blade

- 1** Gigabit Ethernet ports GE0-GE1
- 2** Key management smart card interface
- 3** FC ports 0-15 (bottom to top)

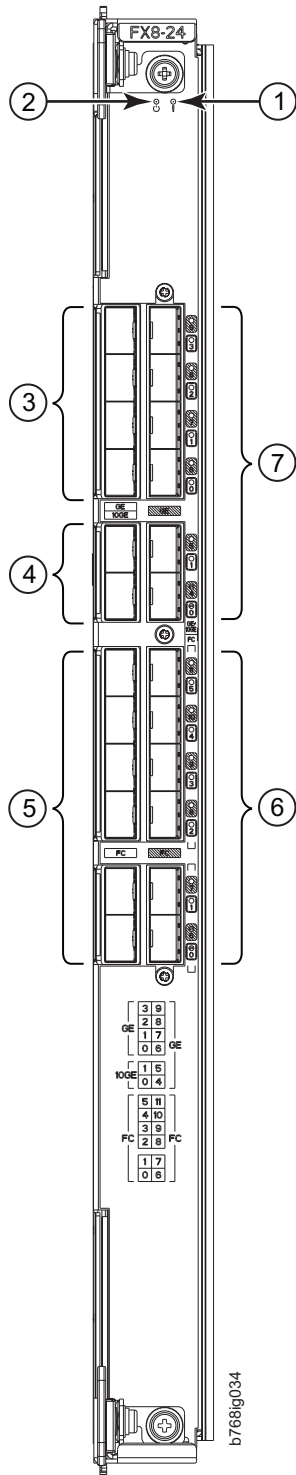

Figure 55. FX8-24 extension blade

- | | | | |
|----------|---|----------|--|
| 1 | Status LED | 5 | FC ports 0-5 (numbered bottom to top) |
| 2 | Power LED | 6 | FC ports 6-11 (numbered bottom to top) |
| 3 | 1 GbE ports 0-3 (numbered bottom to top) | 7 | 1 GbE ports 4-9 (numbered bottom to top) |
| 4 | 10 GbE ports 0-1 (numbered bottom to top) | | |

Notices

This information was developed for products and services offered in the USA.

IBM may not offer the products, services, or features discussed in this document in other countries. Consult your local IBM representative for information on the products and services currently available in your area. Any reference to an IBM product, program, or service is not intended to state or imply that only that IBM product, program, or service may be used. Any functionally equivalent product, program, or service that does not infringe on any IBM intellectual property right may be used instead. However, it is the user's responsibility to evaluate and verify the operation of any non-IBM product, program, or service.

IBM may have patents or pending patent applications covering subject matter described in this document. The furnishing of this document does not give you any license to these patents. You can send license inquiries, in writing to:

*IBM Director of Licensing
IBM Corporation
North Castle Drive
Armonk, N.Y. 10504-1785
U.S.A.*

For additional information, visit the web at:
www.ibm.com/ibm/licensing/contact/

The following paragraph does not apply to the United Kingdom or any other country where such provisions are inconsistent with local law:

INTERNATIONAL BUSINESS MACHINES CORPORATION PROVIDES THIS PUBLICATION "AS IS" WITHOUT WARRANTY OF ANY KIND, EITHER EXPRESS OR IMPLIED, INCLUDING, BUT NOT LIMITED TO, THE IMPLIED WARRANTIES OF NON-INFRINGEMENT, MERCHANTABILITY OR FITNESS FOR A PARTICULAR PURPOSE. Some states do not allow disclaimer of express or implied warranties in certain transactions, therefore, this statement may not apply to you.

This information could include technical inaccuracies or typographical errors. Changes are periodically made to the information herein; these changes will be incorporated in new editions of the publication. IBM may make improvements and/or changes in the product(s) and/or the program(s) described in this publication at any time without notice.

Any references in this information to non-IBM websites are provided for convenience only and do not in any manner serve as an endorsement of those websites. The materials at those websites are not part of the materials for this IBM product and use of those websites is at your own risk.

IBM may use or distribute any of the information you supply in any way it believes appropriate without incurring any obligation to you.

Any performance data contained herein was determined in a controlled environment. Therefore, the results obtained in other operating environments may vary significantly. Some measurements may have been made on development-level

systems and there is no guarantee that these measurements will be the same on generally available systems. Furthermore, some measurement may have been estimated through extrapolation. Actual results may vary. Users of this document should verify the applicable data for their specific environment.

Information concerning non-IBM products was obtained from the suppliers of those products, their published announcements or other publicly available sources. IBM has not tested those products and cannot confirm the accuracy of performance, compatibility or any other claims related to non-IBM products. Questions on the capabilities of non-IBM products should be addressed to the suppliers of those products.

If you are viewing this information in softcopy, the photographs and color illustrations may not appear.

Trademarks

IBM, the IBM logo, and [ibm.com](http://www.ibm.com)[®] are trademarks or registered trademarks of International Business Machines Corporation in the United States, other countries, or both. A complete and current list of other IBM trademarks is available on the Web at www.ibm.com/legal/copytrade.shtml

Adobe, the Adobe logo, PostScript, and the PostScript logo are either registered trademarks or trademarks of Adobe Systems Incorporated in the United States, and/or other countries.

Java[™] and all Java-based trademarks and logos are trademarks of Sun Microsystems, Inc. in the United States, other countries, or both.

Linux is a registered trademark of Linus Torvalds in the United States, other countries, or both.

Microsoft and Windows are trademarks of Microsoft Corporation in the United States, other countries, or both.

UNIX is a registered trademark of The Open Group in the United States and other countries.

Other product and service names might be trademarks of IBM or other companies.

Electronic emission notices

The following statements apply to this product. The statements for other products intended for use with this product will appear in their accompanying manuals.

Federal Communications Commission (FCC) Class A Statement

This equipment has been tested and complies with the limits for a Class A digital device, pursuant to Part 15 of the FCC Rules. These limits are designed to provide reasonable protection against harmful interference when the equipment is operated in a commercial environment. This equipment generates, uses, and can radiate radio frequency energy and, if not installed and used in accordance with the instruction manual, may cause harmful interference to radio communications. Operation of this equipment in a residential area is likely to cause harmful interference, in which case the user will be required to correct the interference at his own expense.

Properly shielded and grounded cables and connectors must be used in order to meet FCC emission limits. IBM is not responsible for any radio or television interference caused by using other than recommended cables and connectors or by unauthorized changes or modifications to this equipment. Unauthorized changes or modifications could void the user's authority to operate the equipment.

This device complies with Part 15 of the FCC Rules. Operation is subject to the following two conditions: (1) this device may not cause harmful interference, and (2) this device must accept any interference received, including interference that may cause undesired operation.

Industry Canada Class A Emission Compliance Statement

This Class A digital apparatus complies with Canadian ICES-003.

Avis de conformité à la réglementation d'Industrie Canada

Cet appareil numérique de la classe A est conforme à la norme NMB-003 du Canada.

European Union EMC Directive Conformance Statement

This product is in conformity with the protection requirements of EU Council Directive 2004/108/EC on the approximation of the laws of the Member States relating to electromagnetic compatibility. IBM cannot accept responsibility for any failure to satisfy the protection requirements resulting from a non-recommended modification of the product, including the fitting of non-IBM option cards.

Attention: This is an EN55022 Class A product. In a domestic environment this product may cause radio interference in which case the user may be required to take adequate measures.

Responsible manufacturer:
International Business Machines Corp.
New Orchard Road
Armonk, New York 10504
Tel: 919-499-1900

European community contact:
IBM Deutschland GmbH

Technical Regulations, Department M372
IBM-Allee 1, 71139 Ehningen, Germany
Tele: +49 7032 15 2941
e-mail: lugi@de.ibm.com

Germany Electromagnetic Compatibility Directive

Deutschsprachiger EU Hinweis:

Hinweis für Geräte der Klasse A EU-Richtlinie zur Elektromagnetischen Verträglichkeit

Dieses Produkt entspricht den Schutzanforderungen der EU-Richtlinie 2004/108/EG zur Angleichung der Rechtsvorschriften über die elektromagnetische Verträglichkeit in den EU-Mitgliedsstaaten und hält die Grenzwerte der EN 55022 Klasse A ein.

Um dieses sicherzustellen, sind die Geräte wie in den Handbüchern beschrieben zu installieren und zu betreiben. Des Weiteren dürfen auch nur von der IBM empfohlene Kabel angeschlossen werden. IBM übernimmt keine Verantwortung für die Einhaltung der Schutzanforderungen, wenn das Produkt ohne Zustimmung der IBM verändert bzw. wenn Erweiterungskomponenten von Fremdherstellern ohne Empfehlung der IBM gesteckt/eingebaut werden.

EN 55022 Klasse A Geräte müssen mit folgendem Warnhinweis versehen werden: "Warnung: Dieses ist eine Einrichtung der Klasse A. Diese Einrichtung kann im Wohnbereich Funk-Störungen verursachen; in diesem Fall kann vom Betreiber verlangt werden, angemessene Maßnahmen zu ergreifen und dafür aufzukommen."

Deutschland: Einhaltung des Gesetzes über die elektromagnetische Verträglichkeit von Geräten

Dieses Produkt entspricht dem "Gesetz über die elektromagnetische Verträglichkeit von Geräten (EMVG)". Dies ist die Umsetzung der EU-Richtlinie 2004/108/EG in der Bundesrepublik Deutschland.

Zulassungsbescheinigung laut dem Deutschen Gesetz über die elektromagnetische Verträglichkeit von Geräten (EMVG) (bzw. der EMC EG Richtlinie 2004/108/EG) für Geräte der Klasse A

Dieses Gerät ist berechtigt, in Übereinstimmung mit dem Deutschen EMVG das EG-Konformitätszeichen - CE - zu führen.

Verantwortlich für die Einhaltung der EMV Vorschriften ist der Hersteller:
International Business Machines Corp.
New Orchard Road
Armonk, New York 10504
Tel: 919-499-1900

Der verantwortliche Ansprechpartner des Herstellers in der EU ist:
IBM Deutschland GmbH
Technical Regulations, Abteilung M372
IBM-Allee 1, 71139 Ehningen, Germany
Tele: +049 7032 15 2941
e-mail: lugi@de.ibm.com

Generelle Informationen:

Das Gerät erfüllt die Schutzanforderungen nach EN 55024 und EN 55022 Klasse A.

People's Republic of China Class A Electronic Emission Statement

中华人民共和国“A类”警告声明

声明

此为A级产品，在生活环境中，该产品可能会造成无线电干扰。在这种情况下，可能需要用户对其干扰采取切实可行的措施。

Japan Voluntary Control Council for Interference (VCCI) Class A Statement

この装置は、クラス A 情報技術装置です。この装置を家庭環境で使用する
と電波妨害を引き起こすことがあります。この場合には使用者が適切な対策
を講ずるよう要求されることがあります。 VCCI-A

Translation: This is a Class A product based on the standard of the VCCI Council. If this equipment is used in a domestic environment, radio interference may occur, in which case, the user may be required to take corrective actions.

Japan Electronics and Information Technology Industries Association (JEITA) Statement

Japanese Electronics and Information Technology Industries Association (JEITA)
Confirmed Harmonics Guideline (products greater than 20 A per phase).

高調波ガイドライン準用品

jeita2

Korea Communications Commission (KCC) Class A Statement

Please note that this equipment has obtained EMC registration for commercial use. In the event that it has been mistakenly sold or purchased, please exchange it for equipment certified for home use.

이 기기는 업무용(A급)으로 전자파적합기기로서 판매자 또는 사용자는 이 점을 주의하시기
바라며, 가정외의 지역에서 사용하는 것을 목
적으로 합니다.

Russia Electromagnetic Interference (EMI) Class A Statement

ВНИМАНИЕ! Настоящее изделие относится к классу А.
В жилых помещениях оно может создавать
радиопомехи, для снижения которых необходимы
дополнительные меры

rusemi

Australia and New Zealand Class A Statement

Attention: This is a Class A product. In a domestic environment this product might cause radio interference in which case the user might be required to take adequate measures.

Taiwan Class A Electronic Emission Statement

警告使用者：
這是甲類的資訊產品，在
居住的環境中使用時，可
能會造成射頻干擾，在這
種情況下，使用者會被要
求採取某些適當的對策。

taiemi

Index

Numerics

- 24-inch load plate
 - part number 14
 - using 22

A

- about this document xxv
 - how to send your comments iv
- ac power
 - removing xxii
- accessibility features for this product xxvi
- application blades
 - FX8-24 81
- attaching
 - Fibre cables 44
- attention notice
 - definition xix
 - example xix
- attention notices xix

B

- backing up the configuration 49
- backup
 - configuration file 50
- blade
 - control processor 5
 - core switch 5
 - CP8 5
 - CR16-8 5
 - encryption 5
 - FC16-32 5
 - FC16-48 5
 - FC8-32E 5
 - FC8-48E 5
 - FC8-64 5
 - FCIP extension 5
 - FS8-18 5
 - FX8-24 5
 - port 5
- blades
 - FC16-32 129
 - FC8-32E 131
 - FC8-48E 131
 - FC8-64 132
- blower assembly
 - installing 100
 - removing 100, 101
- brackets, installing 20
- bridge tool 14
 - ordering 14
 - using 22
- Brocade
 - documents xxvi
- Brocade documents xxv

C

- C36
 - cabinet 13
- C8P blade
 - installing 85, 89
 - removing 85, 88
 - verifying operation 90
- cabinet
 - C36 13
 - installing a SAN768B-2 16
- cable management comb
 - high density 80
 - installing 80
 - lower density 80
 - removing 80
- cable management tray
 - removing 81
- cable routing tables 123
- cables
 - attaching 44
 - installing 44
 - managing 46
- caution notices xvi
 - definition xvi
 - examples xvii
- chassis
 - installing components 118
 - removing 118
 - replacing 118
- chassis door 79
 - installing 79
 - removing 79
- chassis replacement, preparation 113
- chassis replacement, verifying need 113
- chassis, installing components 118
- chassis, replacing 112
- comments
 - sending iv
- components
 - installing 79
 - removing 79
- configuration
 - backing up 49
 - encryption blade 35
 - parameters 37
- configuration file
 - backup 50
 - uploading 50
- configuration parameters, initial 38
- configuring
 - encryption 48
 - IP addresses 38
 - SAN768B-2 35
- connection
 - serial 37
- connection, Ethernet 40
- control processor blade
 - CP8 5
- cords, power 148
- core switch blade
 - CR16-8 5

- CP8
 - control processor blade 5
- CP8 blade
 - verifying 86
- CR blade
 - installing 97
- CR16-8
 - core switch blade 5
- CR16-8 blade
 - installing 95
 - removing 95, 96
- critical information
 - recording 87
- critical SAN information
 - recording 114
- critical SAN768B-2 information
 - recording 114

D

- danger notices xiii
 - definitions xiii
 - examples xiii
- data transmission
 - distance 148
 - range 148
 - speed 148
- date
 - setting 41
- diagnostics 153
- director of licensing, address 179
- disconnecting
 - SAN768B-2 from network and fabric 117
- documents
 - Brocade xxv
 - product xxv
- documents, Brocade xxv
- documents, product xxv
- Domain ID 41
- door, chassis 79
- double encryption
 - avoiding 49, 137
- downloading
 - firmware 51

E

- edition notice ii
- electronic emission notices 182
- encryption
 - configuration tasks 49
 - configuring 48
 - double 49, 137
 - planning 47
 - pre-initialization tasks 48
 - redundancy 47
- encryption blade
 - configuration 35
 - description 151

- encryption blade (*continued*)
 - features 151
 - FS8-18 59, 81
 - installing 135
 - monitoring 59
 - removing 81
 - status 59
- environmental notices xiii, xxiii
- environmental requirements 147
- ESD 130, 131, 132
- ESD strap 132, 134, 135
- Ethernet connection 40
 - establishing 40
- extension blade
 - installing 134
- external machine checks xxii

F

- fabric configuration 122
- fabric configuration, verifying 122
- Fabric OS
 - compatibility 50
 - firmware updates 50
 - release notes 50
- fabric, reconnecting 121
- facility requirements 145
- FC16-32
 - port blade 5
- FC16-32 blade
 - installing 83
 - LEDs 67
 - removing 82
 - status 59, 67
- FC16-32 port blades 81, 129
- FC16-48
 - port blade 5
- FC16-48 blade
 - installing 83
 - LEDs 67
 - removing 82
 - status 59, 67
- FC16-48 port blades 81, 129
- FC3632
 - installing 32-port blade 129
- FC3633
 - installing Enhanced 32-port 8 Gbps blade 131
- FC3648
 - installing 48-port blade 129
 - installing Enhanced 48-port 8 Gbps blade 131
- FC3864
 - installing 64-port blade 132
- FC3890
 - FX8-24 blade 134
- FC3895
 - FS8-18 encryption blade 135
 - installing 135
- FC7230
 - FIPS seals 137
- FC7871
 - QSFP inter-chassis link (ICL) 137
- FC7873
 - QSFP inter-chassis link (ICL) 138
- FC8-32E
 - port blade 5

- FC8-32E blade
 - installing 83
 - removing 82
 - status 59
- FC8-32E port blades 81, 131
- FC8-48 port blades 81
- FC8-48E
 - port blade 5
- FC8-48E blade
 - installing 83
 - removing 82
 - status 59
- FC8-48E port blades 81, 131
- FC8-64
 - port blade 5
- FC8-64 blade
 - installing 83
 - LEDs 67
 - removing 82
 - status 59, 67
- FC8-64 port blades 81, 132
- FCIP extension blade
 - FX8-24 59
- features
 - high availability 8
- features and components 1
- features, Installing new 129
- features, software 9
- Fibre cables
 - attaching 44
- filler panel 84
- FIPS seals
 - installing 137
- FIPS security seals 10
- firmware
 - downloading 51
 - installing 51
- firmware updates 50
- FRU
 - weights 144
- FRUs
 - Smart card 48
- FS8-18
 - description 151
 - encryption blade 151
 - encryption port blade 5
 - features 151
- FS8-18 blade
 - installing 83
 - removing 82
 - status 59
- FS8-18 encryption blade 65
 - components 65
 - installing 135
 - LEDs 67
 - status 67
- FX8-24
 - FCIP extension blade 5
- FX8-24 blade 151
 - components 66
 - installing 83, 134
 - removing 82
 - status 59
- FX8-24 extension blade
 - components 178
 - illustration 66

G

- getting help iii

H

- hardware, verifying 120
- help iii
- high availability 8
 - features 8
- how to send your comments iv

I

- IBM
 - notices 179
 - trademarks 181
- ICL
 - core/edge topology 111
 - full mesh topology 111
 - parallel cabling 110
- ID, Domain 41
- initial configuration parameters 38
- inspections, safety xxii
- installation
 - planning 13
 - preparation 13
- installation guidelines 15
- installing 107
 - blower assembly 100
 - brackets 20
 - chassis door 79
 - components 79, 118
 - CP8 blade 85, 89
 - CR blade 97
 - CR16-8 blade 95
 - FC16-32 81
 - FC16-32 blade 83
 - FC16-48 81
 - FC16-48 blade 83
 - FC3890 134
 - FC3895 135
 - FC8-32E 81
 - FC8-32E blade 83
 - FC8-48E 81
 - FC8-48E blade 83
 - FC8-64 81
 - FC8-64 blade 83
 - filler panel 84
 - FIPS seals 137
 - firmware 51
 - FS8-18 81
 - FS8-18 encryption blade 83, 135
 - FX8-24 81
 - FX8-24 blade 83, 134
 - inter-chassis link (ICL) cable 109
 - mSFP 104
 - mSFPs 44
 - port blade 84, 129, 131, 132
 - power supply 98
 - QSFP inter-chassis link (ICL) 137, 138
 - SAN768B-2 13, 16, 22
 - time required 16
 - tools required 17
 - SFP+ 104
 - SFP+s 44

- installing (*continued*)
 - WWN bezel and card 101
- installing components 79
- Installing new features 129
- intellectual property 179
- inter-chassis link (ICL)
 - status 108
- inter-chassis link (ICL) cable
 - installing 109
- inter-chassis link (QSFP) cable
 - installing 107
 - removing 107, 109
- internal machine checks xxii
- Interoperability Matrix 50
- introduction 1
- IP addresses
 - SAN768B-2 38
- IP addresses, SAN768B-2 38

L

- labels, safety xviii
- LEDs
 - encryption blades 67
 - port blades 67
- license, for patents 179
- licenses
 - software 43
- lift tool 14, 16
 - ordering procedure 14
 - part number 14
 - United States ordering procedure 14
 - using 22, 31
 - world trade ordering procedure 14
- local time
 - synchronizing 42
- login
 - serial console port 38

M

- machine checks
 - external xxii
 - internal xxii
- master keys 47
- modem 35
- mSFP
 - installing 104
 - removing 104
- mSFPs
 - compatible 44
 - installing 44

N

- network manageability 11
- Network Management System 11
- network, reconnecting 121
- new features, Installing 129
- notice, edition ii
- notices
 - attention xix
 - caution xvi
 - danger xiii
 - environmental xiii, xxiii
 - general 179

- notices (*continued*)
 - IBM 179
 - patents 179
 - safety xiii
 - safety and environmental xiii
 - types xiii
- notices ,danger xiii
- notices and labels
 - safety xiii
- notices, attention xix
- notices, caution xvi
- NTP server 42

O

- ordering the lift tool and the 24-inch load plate 14
- organizing
 - cables 46
- overview 1

P

- parameters
 - configuration 37
- parameters, initial configuration 38
- part number
 - 24-inch load plate 14
 - lift tool 14
- parts
 - power cords 148
- password 38
 - changing 38
 - saving 50
- patents 179
- PID mode, verifying 43
- port blade
 - FC16-32 59
 - FC16-48 59
 - FC8-48E 59
 - FC8-64 59
 - FC86-32E 59
 - FX8-24 59
- installing 81, 83, 129, 131, 132
- monitoring 59
- removing 81
- status 59

- port blades
 - FC16-32 81
 - FC16-48 81
 - FC8-32E 81
 - FC8-48E 81
 - FC8-64 81
- port blades, FC16-32 81, 129
- port blades, FC16-48 81
- port blades, FC8-32E 81, 131
- port blades, FC8-48E 81
- port blades, FC8-64 81, 132
- port groups
 - trunking 44
- port numbering 28
 - fully populated (256 ports) 29
- power
 - cords 148
 - off 51
 - SAN768B-2 37

- power specifications 145
- power supply
 - filler panel 98
 - installing 98
 - removing 98
- preparing for chassis replacement 113
- product
 - components 3
 - features 3
 - features and components 1
 - hardware components 3
 - introduction 1
 - overview 1
 - reliability 8
 - serviceability 9
 - software features 9
 - specifications 141
- product documents xxv
- product specifications 141
- providing power to the SAN768B-2 37

Q

- QSFP inter-chassis link (ICL)
 - installing 137, 138

R

- rack
 - safety xx
- rack relocation safety xxi
- rack safety xx
- read this first iii
- reconnecting to the fabric 121
- reconnecting to the network 121
- recording
 - critical information 87
 - critical SAN information 114
 - critical SAN768B-2 information 114
- release notes
 - Fabric OS 50
- reliability 8
- removing
 - ac power xxii
 - blower assembly 100, 101
 - cable management tray 81
 - chassis 118
 - chassis door 79
 - components 79, 117
 - CP8 blade 85, 88
 - CR16-8 blade 95, 96
 - FC16-32 81
 - FC16-32 blade 82
 - FC16-48 81
 - FC16-48 blade 82
 - FC8-32E 81
 - FC8-32E blade 82
 - FC8-48E 81
 - FC8-48E blade 82
 - FC8-64 81, 82
 - filler panel 84
 - FS8-18 81
 - FX8-24 81
 - FX8-24 blade 82
 - inter-chassis link (QSFP) cable 107, 109

- removing (*continued*)
 - mSFP 104
 - port blade 84
 - power supply 98
 - SAN768B-2 13, 31
 - SFP+ 104
 - WWN bezel and card 101
- removing components 79
- replacing
 - chassis 112, 118
 - WWN card 101
- requirements
 - environmental 147
 - facility 145

S

- safety xiii
 - inspections xxii
 - labels xiii, xviii
 - examples xviii
 - notices xiii
 - rack xx
 - rack installation xx
 - rack relocation xxi
- safety inspection
 - external machine checks xxii
 - internal machine checks xxii
- safety inspections xxii
- safety labels xviii
- safety notices xiii
- safety, rack xx
- safety, rack installation xx
- safety, rack relocation xxi
- SAN Switch Cabinet C36 13
- SAN768B-2
 - configuring 35
 - installation guidelines 15
 - installing 13
 - IP addresses 38
 - library xxv
 - physical dimensions 144
 - providing power 37
 - removing 13, 31
 - size 144
 - starting 35
 - switch name 40
 - weight 144
- security 10
- security features 10
- security features table 10
- serial connection 37
- serial connection, establishing 37
- serial console port
 - login 38
- serviceability 9
- setting
 - date 41
 - Domain ID 41
 - time 41
 - timezone 41
- SFP+
 - installing 104
 - removing 104
- SFP+s
 - compatible 44
 - installing 44

- Smart card 48
- SNMP 11
- software features 9
- software licenses 43
 - installed 43
- specifications
 - power 145
- specifications, product 141
- standard features
 - software
 - Advanced Zoning 10
 - Fabric Watch 10
 - ISL Trunking 10
 - Performance Monitoring 10
 - Web Tools 10
- standard software features 10
- starting
 - SAN768B-2 35
- status
 - encryption blades 67
 - FC16-32 blade 67
 - FC16-48 blade 67
 - FC8-64 blade 67
 - FS8-18 encryption blade 67
 - inter-chassis link (ICL) 108
 - port blades 67
- strap, ESD 132, 134, 135
- switch name 40
- synchronizing
 - time zone 42
- system
 - power off 51
 - shutdown 51
 - tuning 163
- system architecture 141

T

- tables, cable routing 123
- time
 - setting 41
- time required
 - installing a SAN768B-2 16
- time server
 - NTP 42
- time zone
 - setting 41
- tools required
 - installing a SAN768B-2 17
- trademarks 181
- transmission range
 - multi-mode media 148
 - OM1 148
 - OM2 148
 - OM3 148
 - OM4 148
 - SFP types 148
 - single mode media 148
 - transceiver 148
- trunking
 - port groups 44
- tuning 163

V

- verifying
 - chassis replacement need 113
 - CP8 blade 86
 - fabric configuration 122
- verifying hardware 120
- verifying operation
 - CP8 blade 90
- verifying PID mode 43
- VLAN 40

W

- websites iii
- weights, FRUs 144
- who should read this document xxv
- WWN bezel 101
- WWN card 101
- WWN card, replacing 101



Part Number: 98Y5380

Printed in USA

GA32-0893-04



(1P) P/N: 98Y5380

