

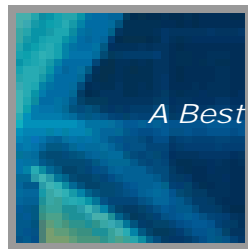

# Quick Start Guide to FlashCopy Manager for SAP® on Oracle® Database



*A Best Practices Paper*

This document can be found in the IBM Techdocs library.

Version 1.1 (2010-01-25)

*Axel Westphal* ([awestphal@de.ibm.com](mailto:awestphal@de.ibm.com))

*Wilhelm Gardt* ([willigardt@de.ibm.com](mailto:willigardt@de.ibm.com))

IBM Systems and Technology Group (STG)  
IBM System Storage - Advanced Technical Support (ATS)  
European Storage Competence Center (ESCC), Mainz, Germany

## Trademarks

The following are trademarks of the International Business Machines Corporation in the United States and/or other countries:

AIX, eServer, FICON, IBM, IBM (logo), iSeries, OS/390, pSeries, RS/6000, POWER, WebSphere, xSeries, z/OS, zSeries,  
IBM XIV Storage System, DS4000, DS6000, DS8000, SAN Volume Controller, System Storage, FlashCopy, System p,  
System z, System x, System I, Lotus, Lotus Notes, Notes, Domino

For a complete list of IBM Trademarks, see [www.ibm.com/legal/copytrade.shtml](http://www.ibm.com/legal/copytrade.shtml)

The following are trademarks or registered trademarks of other companies:

Java and all Java-related trademarks and logos are trademarks of Sun Microsystems, Inc.

SAP, SAP R/3 Enterprise, NetWeaver and SAP ERP are trademarks of SAP AG in Germany, other countries, or both.

UNIX is a registered trademark of The Open Group in the United States and other countries.

Microsoft, Windows, Windows Server 2008, SQL Server 2008 and Excel are registered trademarks of Microsoft Corporation.

Intel is a registered trademark of Intel Corporation.

Other company product and service names may be trademarks or service marks of their respective owners.

## Disclaimer

This paper is intended to be used as a guide to help people working with IBM XIV Storage Systems. It discusses findings based on configurations that were created and tested under laboratory conditions. These findings may not be realized in all customer environments, and implementation in such environments may require additional steps, configurations, and performance analysis. This information does not constitute a specification or form part of the warranty for any IBM or XIV products. Specific parameters or settings that are described in this document may have been set to meet the requirements of this study and do not necessarily represent "correct", "preferred" or "recommended" settings for a production environment.

No part of this document may be reproduced or transmitted in any form without written permission from IBM Corporation. Product data is subject to change without notice. This information could include technical inaccuracies or typographical errors. IBM may make improvements and/or changes in the product(s) and/or program(s) at any time without notice. Any statements regarding IBM's future direction and intent are subject to change or withdrawal without notice, and represent goals and objectives only. References in this document to IBM products, programs, or services do not imply that IBM intends to make such products, programs or services available in all countries in which IBM operates or does business. Any reference to an IBM Program Product in this document is not intended to state or imply that only that program product may be used. Any functionally equivalent program, that does not infringe IBM's intellectual property rights, may be used instead. It is the user's responsibility to evaluate and verify the operation of any non-IBM product, program or service.

THE INFORMATION PROVIDED IN THIS DOCUMENT IS DISTRIBUTED "AS IS", WITHOUT ANY WARRANTY, EITHER EXPRESS OR IMPLIED. IBM EXPRESSLY DISCLAIMS ANY WARRANTIES OF MERCHANTABILITY, FITNESS FOR A PARTICULAR PURPOSE OR NONINFRINGEMENT OR INTEROPERABILITY.

IBM shall have no responsibility to update this information. IBM products are warranted according to the terms and conditions of the agreements (e.g., IBM Customer Agreement, Statement of Limited Warranty, International Program License Agreement, etc.) under which they are provided. IBM is not responsible for the performance or interoperability of any non-IBM products discussed herein.

The provision of the information contained herein is not intended to, and does not, grant any right or license under any IBM patents or copyrights. Inquiries regarding patent or copyright licenses should be made, in writing, to:

IBM Director of Licensing, IBM Corporation, North Castle Drive, Armonk, NY, 10504-1785, U.S.A.

The use of this information or the implementation of any of these techniques is a customer responsibility and depends on the customer's ability to evaluate and integrate them into their operating environment. Customers attempting to adapt these techniques to their own environments do so at their own risk.

## **Abstract**

Backups of SAP® systems are normally performed within a window during batch processing because the impact of the backup load on a database or application can be best tolerated. Compressing all backup activities into this backup window causes an extremely high peak workload for the system infrastructure (network, servers, tape drives). Because of growing database volumes, an increasing number of SAP systems and the business need for 24 by 7 application availability, the backup window can become a key obstacle in meeting service level requirements.

Storage-based FlashCopy or Snapshot solutions provide the operational flexibility necessary for today's IT infrastructure:

- *Zero impact* backups can be started any time during the daily operation of a SAP system, because the FlashCopy technique minimizes the impact on the application (server CPU load, database backup window).
- Backups can be made in two steps: point in time copy to disk and delayed or immediate backup to tape in order to balance tape load and more efficiently utilize the existing infrastructure.
- Backups can be made more frequently (to disk) in order to minimize the amount of log files between backups and hence the time needed for forward recovery to the latest point before failure.

IBM Tivoli® Storage FlashCopy® Manager software provides fast application-aware backups and restores leveraging advanced snapshot technologies in IBM storage systems.

This paper covers the installation and configuration of FlashCopy Manager for SAP on an Oracle® database and AIX® operating system. IBM DS8000® and XIV® storage servers have been used as backend storage systems.

*Remark: The correct name of the software product is "IBM Tivoli® Storage FlashCopy® Manager". To facilitate readability of the text, the short name "FlashCopy® Manager" is used in this document.*

## Table of Content

1 Products Overview .....	5
1.1 IBM DS8000® Storage System.....	5
1.2 IBM XIV® Storage System.....	5
1.3 IBM Tivoli Storage FlashCopy® Manager.....	6
2 Hardware/Software Setup (in the Mainz Lab) .....	7
2.1 Hardware and software .....	7
2.2 Volume and Volume Group layout .....	7
2.3 Layout rule violations.....	9
3 FlashCopy Manager Prerequisites .....	10
3.1 Overview.....	10
3.2 Pre-Installation Tasks.....	10
3.3 Secure Shell .....	11
3.4 Installation and Configuration of the CIM Agent (DS8000) .....	11
3.4.1 Configuring the CIM Agent to access the DS8000 .....	13
3.5 Installation and Configuration of the XCLI for XIV.....	14
3.6 TSM Client and Server .....	14
3.7 TSM for Enterprise Resource Planning.....	15
3.7.1 Configure BR*TOOLS to work with TSM for ERP.....	16
4 FlashCopy Manager Installation and Configuration .....	18
4.1 Software Installation .....	18
4.2 Configuration for disk only backup .....	20
4.3 Switching from diskonly to offloaded backup .....	21
5 Backup/Restore scenarios.....	23
5.1 Diskonly Backup.....	24
5.2 Offload to Tivoli Storage Manager .....	26
5.3 Restore from Snapshot .....	28
5.4 Backup and Restore from TSM Server .....	29
5.5 Additional functions .....	29
6 Backup schedule options.....	31
7 Appendix.....	33
7.1 Setup script protocol for SAP/Oracle on IBM XIV .....	33
7.2 Setup script protocol for SAP/Oracle on IBM XIV incl. Offload to TSM Server.....	34
7.3 Setup script protocol for SAP/Oracle on IBM DS8000.....	36

# 1 Products Overview

## 1.1 IBM DS8000® Storage System

The DS8000 system is a cabinet-mounted self-contained disk storage subsystem. It is designed for the higher demands of data storage and data availability that most organizations face today. The DS8000 series benefits using IBM POWER™ processor technology. Its extended connectivity, with up to 128 Fibre Channel/FICON® ports, makes it suitable for multiple server environments in both the open systems and System z® environments. Depending on your specific needs, the DS8000 system can be equipped with SATA drives, FC drives, and Solid® State Drives.

Its switched Fibre Channel architecture, dual processor complex implementation, high availability design, and the advanced Point-in-Time Copy and Remote Mirror and Copy functions that it incorporates make the DS8000 system suitable for mission-critical business functions.

<http://www.redbooks.ibm.com/abstracts/sg246786.html?Open>

<http://www-03.ibm.com/systems/storage/disk/ds8000/index.html>

### DS8000 FlashCopy

The primary objective of FlashCopy is to very quickly create a point-in-time copy of a source volume on a target volume. The benefits of FlashCopy are that the point-in-time target copy is immediately available for use for backups or testing and that the source volume is immediately released so that applications can continue processing with minimal application downtime. The target volume can be either a logical or physical copy of the data, with the latter copying the data as a background process.

The IBM FlashCopy SE feature provides a “track space efficient” copy capability that can greatly reduce the storage capacity needed for point-in-time copies. Only the capacity needed to save pre-change images of the source data is allocated in a copy repository. This enables more space efficient utilization than is possible with the standard FlashCopy function. Furthermore, less capacity can mean fewer disk drives and lower power and cooling requirements, which can help reduce costs and complexity. FlashCopy SE may be especially useful in the creation of temporary copies for tape backup, online application checkpoints, or copies for disaster recovery testing. For more information about FlashCopy SE, refer to the IBM Redpaper at

<http://www.redbooks.ibm.com/abstracts/redp4368.html?Open>

## 1.2 IBM XIV® Storage System

The IBM XIV Storage System is a next-generation high-end open disk storage system. Part of IBM's broad spectrum of system storage and SAN offerings, IBM XIV is an innovative grid based storage system, utilizing off-the-shelf hardware components. The XIV system storage architecture is designed to provide the highest levels of performance, reliability and functionality combined with unprecedented ease of management and with exceptionally low TCO.

More details about the XIV system features and benefits can be found at the following web sites:

<http://www.redbooks.ibm.com/abstracts/sg247659.html?Open>

<http://www.ibm.com/systems/storage/disk/xiv/index.html>

### XIV Snapshots

The snapshot capabilities within the XIV Storage System utilize a metadata, redirect-on-write design that allows snapshots to occur in the millisecond time range with little performance overhead. Up to 16000 full or differential copies can be taken. Any of the snapshots can be made writable, and then snapshots can be taken of the newly writable snapshots. Volumes can even be restored from these writable snapshots. In addition you may take snapshots of Consistency Groups. A Consistency Group is a group of volumes of which a snapshot can be made at the same point in time, thus ensuring a consistent image of all volumes within the group at that time.

### 1.3 IBM Tivoli Storage FlashCopy® Manager

In today's IT world, where application servers are operational 24 hours a day, the data on these servers must be fully protected. With the rapid increase in the amount of data on these servers, their critical business needs and the shrinking backup windows, traditional backup and restore methods may be reaching their limits in meeting these challenging requirements. Snapshot operations can help minimize the impact caused by backups and provide near instant restore capabilities. Since a snapshot operation typically takes much less time than the time for a tape backup, the window during which the data is being backed up can be reduced. This helps facilitate more frequent backups and increases the flexibility of backup scheduling and administration because the time spent for forward recovery through transaction logs after a restore is minimized.

IBM Tivoli Storage FlashCopy Manager uses the copy services capabilities of intelligent storage subsystems to create point-in-time copies. These are application aware copies (FlashCopy® or snapshot) of the production data. This copy is then retained on disk as a backup allowing for a fast restore operation (Flashback). IBM Tivoli Storage FlashCopy Manager also allows mounting the copy on an auxiliary server (backup server) as a logical copy. This copy (instead of the original data on the production server) is made accessible for further processing. This processing includes creating a backup to Tivoli Storage Manager (disk or tape) or performing backup verification functions (for example, the Database Verify Utility).

If a backup to Tivoli Storage Manager fails, IBM Tivoli Storage FlashCopy Manager can restart the backup once the cause of the failure is corrected. In this case, data already committed to Tivoli Storage Manager is not re-sent.

Figure 1 gives an overview about the support applications and storage servers that can use FlashCopy Manager.

Remark: FlashCopy Manager for Windows® supports the applications Microsoft SQL Server® and Microsoft Exchange. IBM DS3000®, DS4000® and DS5000® storage systems are supported by Windows through VSS.

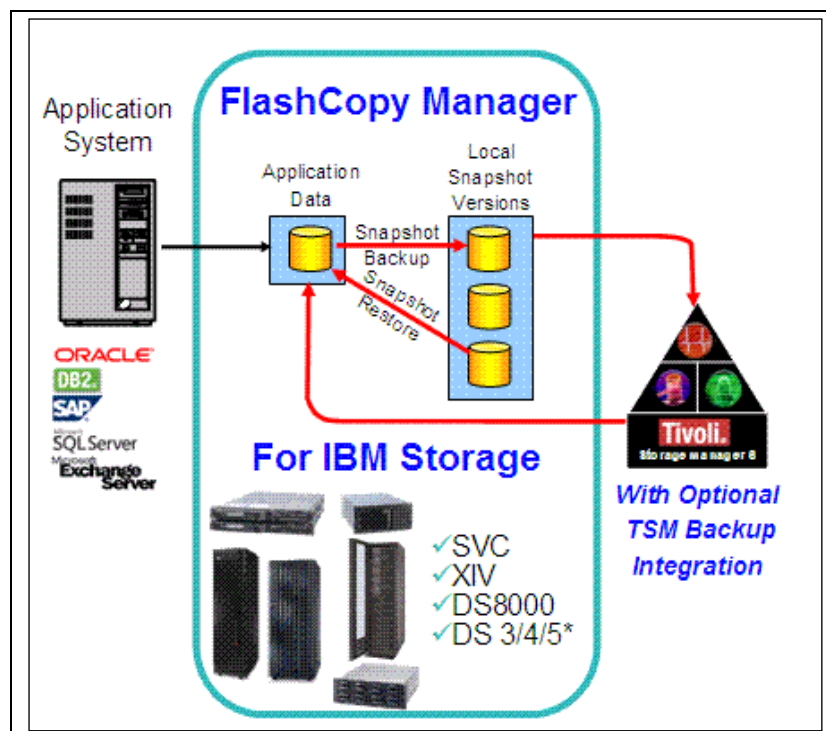

Figure 1: Supported applications and storage systems

More details about FlashCopy Manager's features and benefits can be found at the following web site: <http://www.ibm.com/software/tivoli/products/storage-flashcopy-mgr/>

## 2 Hardware/Software Setup (in the Mainz Lab)

This whitepaper covers the installation and configuration of IBM Tivoli FlashCopy Manager with SAP on Oracle.

The information in this paper is based on FlashCopy Manager 2.1 tests that were run for SAP NetWeaver on an Oracle database at the IBM Systems Lab Europe in Mainz, Germany.

### 2.1 Hardware and software

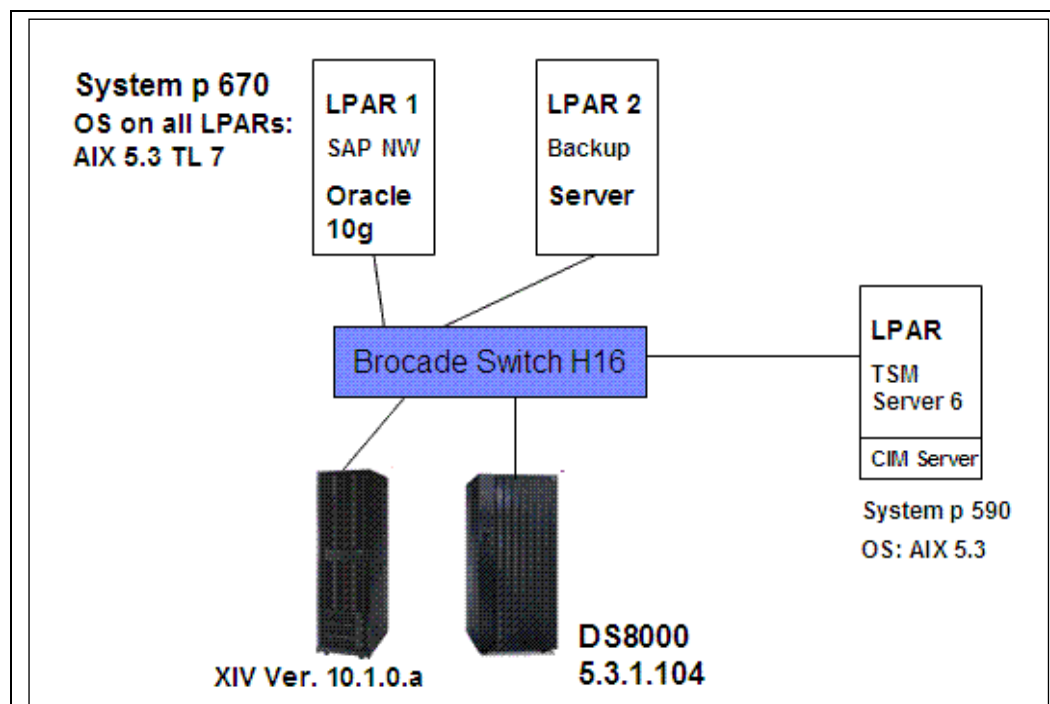

Figure 2: Hardware Setup for FlashCopy Manager with SAP on Oracle

The following software was installed on the SAP system LPAR (LPAR1):

- SAP NetWeaver® 7.0 SR3 ABAP and JAVA AS with Oracle and AIX operating system
- NetWeaver Enterprise Portal (EP)
- SAP Kernel 7.00 Level 144
- Database Oracle 10.2.0.2.0
- Operating System AIX 5.3 TL 7

	System ID (SID)	Host system name
Production system	OON	sapr3ora
Backup system	n/a	sapr3oracl

Table 1: Production / Backup System Hostnames

### 2.2 Volume and Volume Group layout

FlashCopy Manager requires a well-defined volume layout on the storage subsystem and a resulting volume group structure on AIX. Distinct volume groups must be defined for:

- data files and control files (sapdata)
- online redo logs (origlog)
- online redo log mirrors (mirrlog)

- AIX boot disk (rootvg)

Other binaries (e.g. Oracle binaries and SAP kernel) should reside on separate volume groups.

Volume content	Number of logical volumes	Size of logical volumes
Database data files	1	85 GB
Database mirror log files	1	17 GB
Database redo log files	1	17 GB

Table 2: XIV storage system layout

Volume content	Number of logical volumes	Size of logical volumes
Database data files	2	120 GB
Database mirror log files	1	5 GB
Database redo log files	1	5 GB
Database archive	2	10 GB
SAP/Oracle software	2	30 GB

Table 3: DS8000 storage system layout

Remark: In case of the data files, archive logs and SAP/Oracle software, two logical volumes were created on separate DS8000 extent pools to distribute the I/O load across the available DS8000 resources.

As shown in Table 4, the volume group and file system layouts for the DS8000 and the XIV system can be identical.

Volume Group	File System	Size
sapdatavg	/oracle/OON/sapdata1	25 GB
	/oracle/OON/sapdata2	25 GB
	/oracle/OON/sapdata3	25 GB
	/oracle/OON/sapdata4	30 GB
saplogvg	/oracle/OON/origlogA	1 GB
	/oracle/OON/origlogB	1 GB
sapmirrlogvg	/oracle/OON/mirrlogA	1 GB
	/oracle/OON/mirrlogB	1 GB
saparchvg	/oracle/OON/oraarch	10 GB
sapswvg *	/sapmnt/OON	5 GB
	/usr/sap	12 GB
	/oracle	30 GB

Table 4: AIX volume group layout

The DS8000 volume Ids of the SAP production system and the used target volumes for FlashCopy Manager are shown in Table 5. For the XIV no target volumes have to be defined. The snapshots are created during the backup with FlashCopy Manager.

SAP Production LPAR	Volume group	Extent Pool	Volume IDs	Volume size	FlashCopy target volumes
SID: OON	Data	P4,P5	4408, 4508	120 GB	4E20, 4F20
	Redo logs	P5	4509	5 GB	4E21
	Mirror logs	P4	4409	5 GB	4F21
	Archive logs	P4,P5	440A,450A	10 GB	4E22, 4F22
	SAP/Oracle	P4,P5	4407,4507	30 GB	



	Swap	P4,P5	4402,4502	12 GB	
	System	P5	4100	20 GB	

Table 5: DS8000 volume lds from the production server

## 2.3 Layout rule violations

FlashCopy Manager prevents backup or restore operations in an environment that infringe upon the layout rules. Examples of rule violations are:

- (1) An old Oracle database control file copy:

BR1516E Non-database file '/oracle/OON/sapdata1/cntrl/cntrlOON.dbf.sv' found by backup utility on database disk volume

BR1516E Non-database file '/oracle/OON/sapdata3/cntrl/cntrlOON.dbf.sv' found by backup utility on database disk volume

FMM8361E Found non-database files on the file systems to backup. Please provide a negative list or clean your file systems.

Actually the error messages indicate that these file are not part of the database and thus not expected in these directories. In other words these two files are not specified in a *controlfile* statement in the *init<SID>.ora* file.

- (2) One volume group for online redo logs and their mirrors:

BR1516E Non-database file '/oracle/OON/mirrlogB/log\_g12m2.dbf' found by backup utility on database disk volume

BR1516E Non-database file '/oracle/OON/mirrlogA/log\_g13m2.dbf' found by backup utility on database disk volume

BR1516E Non-database file '/oracle/OON/mirrlogA' found by backup utility on database disk volume

BR1516E Non-database file '/oracle/OON/mirrlogB' found by backup utility on database disk volume

BR1516E Non-database file '/oracle/OON/mirrlogB/log\_g14m2.dbf' found by backup utility on database disk volume

BR1516E Non-database file '/oracle/OON/mirrlogA/log\_g11m2.dbf' found by backup utility on database disk volume

BR1516E Non-database file '/oracle/OON/origlogB/cntrl/cntrlOON.dbf.sv' found by backup utility on database disk volume

BR0278E Command output of 'backint -u OON -f backup -i /oracle/OON/sapbackup/.bebyief.lst -t volume -p /oracle/OON/102\_64/dbs/initOON.utl -n /oracle/OON/sapbackup/.bebyief.nls':

FMM8361E Found non-database files on the file systems to backup. Please provide a negative list or clean your file systems.

## 3 FlashCopy Manager Prerequisites

The installation of Tivoli FlashCopy Manager requires several pre-installation tasks to be performed. These tasks are described in an essential document: the pre-install checklist (see chapter 3.2). The pre-install checklist defines hardware and software requirements and describes the volume group layout for the SAP environment.

### 3.1 Overview

This section describes the theoretical background of an SAP backup/restore solution. The concept and products are not explained in detail. Existing links in the document provide references to product manuals, White Papers and other relevant documentation.

Oracle database backup must take several file types into consideration: control files, data files, online redo logs and offline redo logs (also called an archive).

SAP provides the so-called BR\*Tools for Oracle database backup and recovery e.g.

- *brbackup* to back up database files, control files and online redo log files
- *brarchive* to back up the offline redo logs (archive)
- *brrecover* to restore and recover the database after severe errors

SAP also provides an interface description that lets vendors of backup/restore software connect their software products to the SAP BR\*Tools: *backint*. IBM/Tivoli offers "Tivoli Storage Manager for Enterprise Resource Planning® (TSM for ERP)" to interact with IBM's backup/restore solution "Tivoli Storage Manager® (TSM)". The name of the software executable of TSM for ERP is also *backint*. Maybe for this reason many documents use the terms TSM for ERP Systems and *backint*, somewhat imprecisely, as synonyms.

Recommendation: Consider TSM for ERP as a complement to FlashCopy Manager for backups to tape and archiving database redo logs or log files.

The BR\*Tools *brbackup* and *brrestore* interact with FlashCopy Manager to provide Snapshot backups for an SAP database environment. Nevertheless, if FlashCopy Manager is used to offload existing diskonly backups to a TSM Server, neither Oracle nor BR\*Tools must be installed on the associated backup server.

Furthermore an offload backup with FlashCopy Manager requires that the user name and group name of the database instance owner on the production system are also available on the backup server with the same user id (UID) and group id (GID).

Further reading:

SAP Database Guide for Oracle

[http://help.sap.com/saphelp\\_nw04/helpdata/en/42/51b3144a1211d182b80000e829fbfe/frameset.htm](http://help.sap.com/saphelp_nw04/helpdata/en/42/51b3144a1211d182b80000e829fbfe/frameset.htm)

### 3.2 Pre-Installation Tasks

The most recent pre-installation task checklist for FlashCopy Manager can be found at:

<http://www-01.ibm.com/support/docview.wss?&uid=swg21395564>

IBM Tivoli Storage FlashCopy® Manager Version 2.1 Hardware and Software Requirements

The checklist defines hardware and software requirements and describes the volume layout for the SAP environment. To have a smooth installation of FlashCopy Manager it is absolutely necessary that all requirements are fulfilled.

For a list of considerations and decisions to be taken before installing IBM Tivoli Storage FlashCopy® Manager Version 2.1 for AIX, refer to the Installation Planning Sheet that is also available under the previous link.

### 3.3 Secure Shell

A FlashCopy Manager environment that uses one or more backup servers (e.g. to offload backup data to TSM) requires FlashCopy Manager software on production and backup systems. It is possible to separately install and configure FlashCopy Manager on the backup systems running the setup scripts on the backup server(s).

However it is more efficient to maintain the configuration centrally on the production system and create or modify the backup systems' configuration from this central instance. In the latter case communication is required between the production and backup systems.

Two options are available:

- a Secure Shell (OpenSSH) connection
- a NFS-share of the FlashCopy Manager configuration directory (ACS\_DIR) and the database instance-specific installation directory (INST\_DIR)

NFS sharing of the directories is possible, but OpenSSH is the preferred method for FlashCopy Manager. If Secure Shell is used, installation and configuration updates can be controlled centrally on the production server.

If IBM DS8000 Storage System is used, a CIM Agent must also be installed on the servers to control the storage-based copy services. OpenSSH and the CIM Agent must work together with an OpenSSL (Secure Sockets Layer) library.

All required software components are available for download in the web:

OpenSSL: <http://www.ibm.com/systems/p/os/aix/linux/toolbox/download.html>

(follow the link 'AIX Toolbox Cryptographic Content' on the right)

OpenSSH comes with AIX 6.1. Check if this version works before downloading and installing from

<http://sourceforge.net/projects/openssh-aix/files/#>

Software versions that worked together in the tests for this paper are:

CIM 2.6.1

OpenSSH 4.7.0 (openssh.base.client 4.7.0.5301, openssh.base.server 4.7.0.5301)

OpenSSL 0.9.8 (openssl.base 0.9.8.602)

Note that the FlashCopy Manager installation package includes a Pegasus CIM client. This software is used to connect FlashCopy Manager to the CIM agent that manages the DS8000 or SVC Copy Services. XIV which is also supported by FlashCopy Manager is managed via the command line interface xcli i.e. XIV does not require a CIM setup.

Although FlashCopy Manager does not need a separate Pegasus installation, further information is provided here:

CIM Client version Pegasus2.6.1.40\_OSBase1.2.7.40\_SMIS1.2.0.40\_AIX.tar

[https://www14.software.ibm.com/webapp/iwm/web/preLogin.do?lang=en\\_US&source=aixpegcim](https://www14.software.ibm.com/webapp/iwm/web/preLogin.do?lang=en_US&source=aixpegcim)

### 3.4 Installation and Configuration of the CIM Agent (DS8000)

IBM Tivoli Storage FlashCopy Manager accesses FlashCopy® services on DS8000 or SAN Volume Controller through a CIM server. Depending on the storage subsystem microcode level, this CIM server is either embedded directly into the storage subsystem or required to be installed and configured as a proxy CIM server in the environment.

Starting with SAN Volume Controller 4.3.1 and DS8000 R4.1, the CIM server is embedded in the storage device and therefore does not require being installed and configured separately. For prior SAN Volume Controller and DS8000 releases, a proxy CIM server is required and must be configured to manage the necessary storage clusters. Refer to the DS8000 and SAN Volume Controller documentation for configuration details. IBM Tivoli Storage FlashCopy Manager supports both

configuration options for those SAN Volume Controller and DS8000 releases that support both a proxy CIM server and an embedded CIM server.

A DS CIM agent consists of the components shown in Figure 3. Main components are the CIM object manager (CIMOM), the service location protocol (SLP), and the device provider. A device can be a storage server such as the DS8000 storage server. The CIM agent registers itself with the SLP Service Agent (SLP SA) to enable discovery by the Client application. The SLP is a directory service daemon that a client application calls to locate the CIM Object Manager. The client application and the CIMOM communicate through CIM Messages. The CIMOM and device provider communicate through method calls made from the CIMOM to the provider. The device provider communicates with the device through proprietary calls.

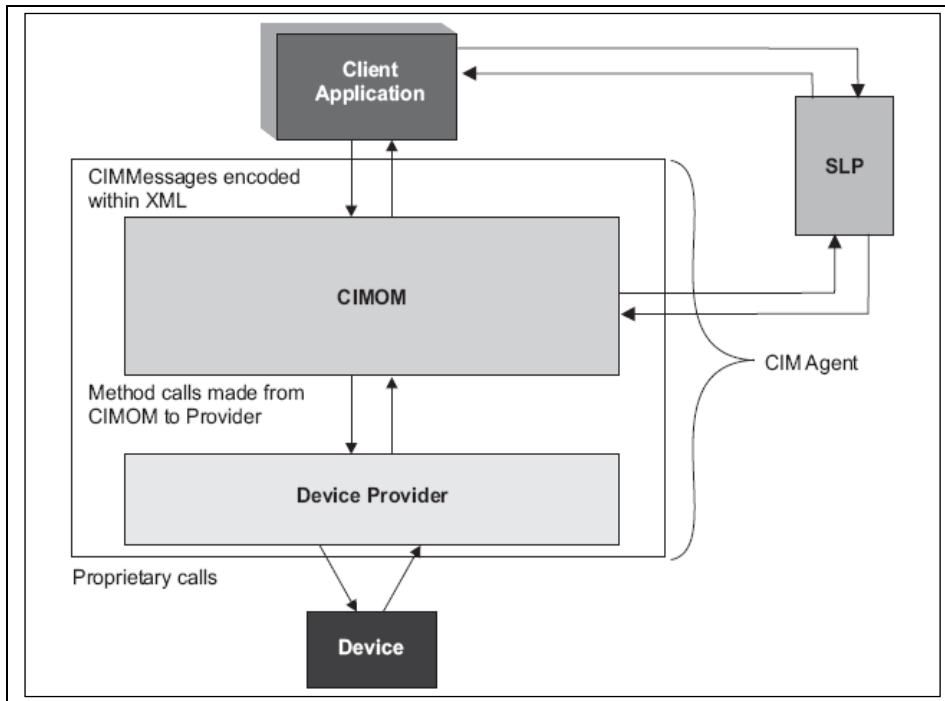

Figure 3: DS CIM Agent components

The DS CIM Agent can coexist with the CIM Client on the same server. However the installation on the backup system is preferred (see Figure 4), because on the production system the CIMOM and particularly Java could impact performance.

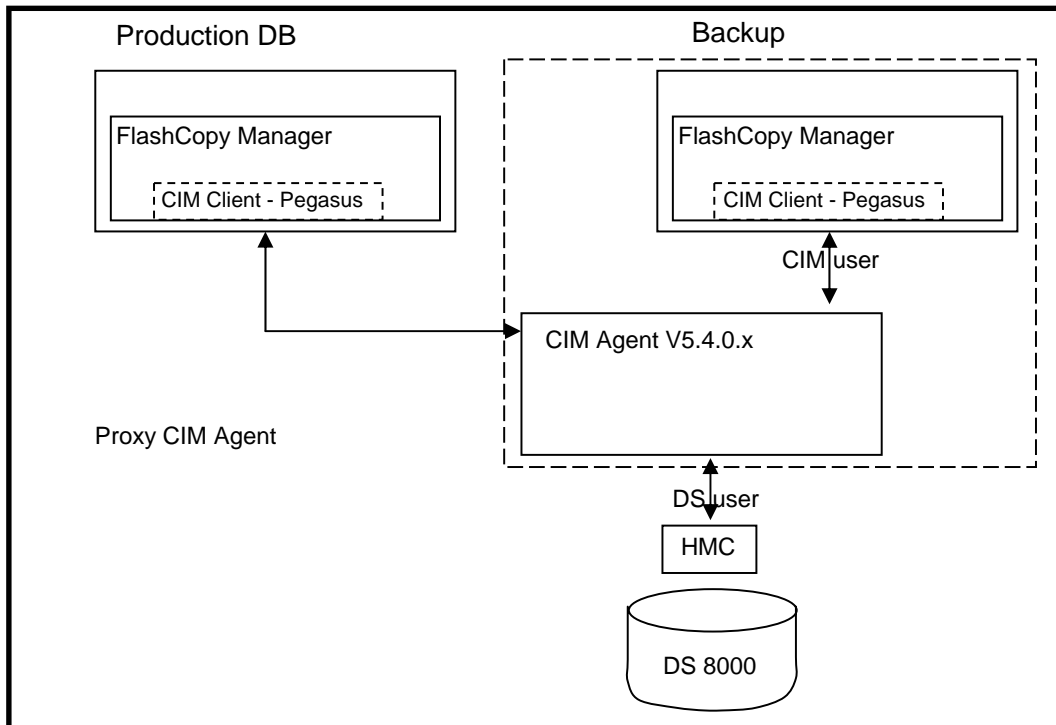

Figure 4: DS CIM Agent for DS8000

To install the CIM agent for DS8000 or SVC download the free available software package from: [http://www-01.ibm.com/support/search.wss?rs=1118&tc=STC4NKB&atr=SWVersion&atrvc=5.4\\*&atrwcs=on&dc=D400&dtm](http://www-01.ibm.com/support/search.wss?rs=1118&tc=STC4NKB&atr=SWVersion&atrvc=5.4*&atrwcs=on&dc=D400&dtm)

During the installation of the CIM Agent the following values have to be specified:

Parameter	Value
Install directory	/opt/ibm/dsagent
HTTPS port	5989
HTTP port	5988

### 3.4.1 Configuring the CIM Agent to access the DS8000

The CIM Agent has to be configured to access the DS8000 storage server. For the configuration on AIX the CIM command line interface must be started in the CIM Agent installation directory: **/opt/IBM/dsagent/bin/**.

With the *dscimcli* command each DS server that the CIM agent should access must be defined: The format of the command *dscimcli* is:

```
./dscimcli mkdev <hmc-ip> -type ds -user <user> -password <password>
```

In this example, the *dscimcli* command configures a DS8000 with the HMC IP 9.155.62.11 and the user "cimsap":

```
bash-3.00# ./dscimcli mkdev 9.155.62.11 -type ds -user cimsap -password passw2rd
Device successfully added.
```

After the DS8000 has been defined the following command verifies that the device is correctly added and has successfully connected:

```
bash-3.00# ./dscimcli lsdev -l
```

Type	IP	IP2	Username	Storage Image	Status	Code Level	Min Codelevel
DS	9.155.62.11	-	cimsap	IBM.2107-7581991	successful	5.3.1.104	5.1.0.309

Environment variable settings are required to issue any of the CIM agent management commands. The start of the profile script `envConf` sets the necessary variables on the UNIX shell:

**source <dest-path>/config/envConf** , where <dest-path> is the destination directory where the CIM agent is installed.

The following commands stop, start and check the status of the CIM Agent:

```
Start the CIM agent with:      startagent
Stop the CIM agent with:     stopagent
CIM agent status:           cimagentstatus
```

Verify the installation of the service location protocol (SLP). SLP is a directory service that a client application calls to locate the CIM Object Manager. Open a Command Prompt window and type the following command to verify that SLP is started: `# ps -ef | grep slpd` If the SLP daemon is started, the following output is displayed:

```
bash-3.00# ps -ef | grep slpd
daemon 438298  1  0 12:51:30  - 0:00 /opt/IBM/dsagent/slp/sbin/slpd
```

Verify the installation of the CIM Agent. Check that the `cimserver` daemon is installed and started by typing the following command: `# ps -ef | grep cimserv`

```
bash-3.00# ps -ef | grep cimserv
root 540692  1  0 12:51:29  - 0:09 [cimserve]
```

### 3.5 Installation and Configuration of the XCLI for XIV

IBM Tivoli Storage FlashCopy Manager requires the IBM XIV® Storage System command-line interface (XCLI) to be installed on all hosts where IBM Tivoli Storage FlashCopy Manager is installed. A CIM server is not required for an XIV connection.

XCLI software download link:

[http://www-01.ibm.com/support/docview.wss?rs=0&context=STJTAG&dc=D400&q1=ssg1\\*&uid=ssg1S4000733&loc=en\\_US&cs=utf-8&lang=](http://www-01.ibm.com/support/docview.wss?rs=0&context=STJTAG&dc=D400&q1=ssg1*&uid=ssg1S4000733&loc=en_US&cs=utf-8&lang=)

Download the “XCLI\_aix64\_2.3.1.tar.gz” package and extract the files on the AIX server where FlashCopy Manager will be installed. The connection to the XIV storage system can be verified with a simple `xcli` command. Log in as root user and enter a `xcli` command e. g.

```
“./xcli -u <user> -p <password> -m <XIV ip-address> pool_list”
```

### 3.6 TSM Client and Server

If an offloaded backup is planned, FlashCopy Manager requires a Tivoli Storage Manager® (TSM) client installation on both the production and backup server.

The client configuration is performed on the production and backup server. In this setup, the TSM Server is running on the server “p590-tic-1-v49.mainz.de.ibm.com” which is reflected in the TSM configuration files, as shown in Figure 5 and Figure 6.

```

SErvername SAPTSM
COMMMethod   TCPip
TCPPort      1500
TCPSeveraddress 9.155.87.188
errorlogname  /tmp/tsmerrlog

```

Figure 5: Example of TSM configuration file “dsm.sys”

```

SErvername      SAPTSM

```

Figure 6: Example for TSM configuration file “dsm.opt”

The basic Tivoli Storage Manager Server code has to be installed on the backup server or any other server and configured with an administrative ID and the storage pools must be available. For more information about planning and installing a Tivoli Storage Manager server, refer to the product documentation, or the IBM Redbook, “*IBM Tivoli Storage Manager Implementation Guide, SG24-5416*”.

It is recommended to have a separate policy domain with a policy set, management class and copy group in Tivoli Storage Manager for each of the Tivoli Data Protection modules. In this setup a separate policy domain and policy set for FlashCopy Manager (Oracle) have been defined.

On the TSM server in the test environment the following TSM objects exist:

```

TSM policy domain:      opsapdom
TSM management class:  osapmclass
TSM node:               sapr3ora

```

Note: Typically separate management classes are defined for backup (BRBACKUPMGTCCLASS) and archive (BRARCHIVEMGTCLASS).

### 3.7 TSM for Enterprise Resource Planning

IBM Tivoli Storage Manager for ERP quickly and confidently restores your SAP database after almost any kind of business interruption. It provides backup and recovery of SAP on Oracle and SAP on DB2 environments.

FlashCopy Manager performs backups to Tivoli Storage Manager storage pools using IBM Tivoli Storage Manager for Enterprise Resource Planning.

Tivoli Storage Manager for Enterprise Resource Planning can be considered as a solution for backups to tape and archiving database redo logs or log files.

TSM for ERP (6.1 or later) has to be installed on the production server and backup server. During the installation the following information has to be specified:

- Oracle SID
- Directory where the SAP BR'Tools are located
- Directory where the init<SID>.utl file is located
- TSM Server name
- TSM Policy domain
- TSM management class
- TSM node name

After the installation of TSM for ERP issue the following command to start TSM for ERP and to specify the password on the production server.

```

./backint -p /oracle/OON/102_64/dbs/initOON.utl -f password

                Data Protection for SAP(R)

                Interface between BR*Tools and Tivoli Storage Manager
                - Version 6, Release 1, Modification 0.0 for AIX LF 64-bit -
                Build: 358 compiled on Nov  4 2008
                (c) Copyright IBM Corporation, 1996, 2008, All Rights Reserved.

BKI2027I: Using TSM-API version 5.4.2.0 (compiled with 5.3.0.0).
BKI2000I: Successfully connected to ProLE on port tdpr3ora64.
BKI0005I: Start of program at: Fri Nov 13 21:25:37 Europe 2009 .
BKI0049I: Please enter password for node SAPR3ORA on server SAPTSM:
BKI0051I: Password successfully verified for node SAPR3ORA on server SAPTSM.
BKI0020I: End of program at: Fri Nov 13 21:25:43 Europe 2009 .
BKI0021I: Elapsed time: 06 sec .
BKI0024I: Return code is: 0.

```

Figure 7: Setting the password for TSM for ERP

The *backint* command, as shown in Figure 7, connects TSM for ERP with the TSM server and stores the TSM node password inside an encrypted file called *init<SID>.bki*. Once this command has been run successfully it is also confirmed that TSM for ERP can connect to the TSM Server.

It is good practice to configure the directory in which the TSM for ERP configuration files are stored as a Network File System (NFS). Thus the backup server can access the configuration files over NFS and many TSM for ERP configuration steps have to be done only once on the production server.

### 3.7.1 Configure BR\*TOOLS to work with TSM for ERP

Navigate to */oracle/<SID>/102\_64/dbs* directory and edit the file *init<SID>.sap*. Check and change if necessary the main parameters, as shown in Figure 9.

```

# backup type [offline | offline_force | offline_standby | offline_split
# | offline_mirror | offline_stop | online | online_cons | online_split
# | online_mirror | online_standby | offstby_split | offstby_mirror
# default: offline
backup_type = online

# backup device type
# [tape | tape_auto | tape_box | pipe | pipe_auto | pipe_box | disk
# | disk_copy | disk_standby | stage | stage_copy | stage_standby
# | util_file | util_file_online | rman_util | rman_disk | rman_stage
# | rman_prep]
# default: tape
backup_dev_type = util_vol

util_par_file = initOON.utl
# --- Note: this parameter causes a brbackup error message if ERP is used
# --- util_options = "-R TSM_BACKUP_FROM_SNAPSHOT = YES"

```

Figure 9: FlashCopy Manager parameters in *init<SID>.sap* file



This configuration file `init<SID>.sap` is used by SAP's BR\*TOOLS to identify TSM for ERP as a backup interface (also called BACKINT). Backup\_type *online* means that the default backup type is online, `util_par_file` means that the BRTOOLS use `initOON.utl` as the configuration file for the backup, backup\_dev\_type *util\_vol* means that the BRTOOLS are using FlashCopy Manager to create disk backups.

Beside the parameters shown in Figure 9, there are more parameters available to control the diskonly backup with FlashCopy Manager: These parameters are also specified in the configuration file `init<SID>.sap`.

**util\_vol\_nlist** *no\_check | <list of files, fully qualified pathes, separated by commas>*

The parameter `util_vol_nlist` defines a list of non-database files or directories which reside on the database and should be included in the backup.

**util\_vol\_access** *none | mount | copy | both*

The parameter `util_vol_access` specifies the accessibility of snapshot backup volumes.

**util\_vol\_unit** *disk\_vol | sap\_data | all\_data | all\_dbf*

The parameter `util_vol_unit` specifies the smallest unit that can be backed up with a snapshot or clone. The recommended value is 'all\_data'. This requires a disk layout with at least three volume groups as shown in Table 4: AIX volume group layout.

To configure offloaded backups, the `init<SID>.utl` file has to be modified with an editor. When switching from diskonly backup to offloaded backup it must be ensured that the parameters as shown in Figure 10 are specified in the `init<SID>.utl` file.

```
# FlashCopy Manager offload backup section
TARGET_DATABASE_SUSPEND    YES
TSM_BACKUP_FROM_SNAPSHOT  YES
MAX_SNAPSHOT_VERSIONS     3
ACSD                       sapr3ora 57328
ACS_DIR                    /oracle/<SID>/acs
```

Figure 10: Parameters for offloaded backup (`init<SID>.utl`)

For more detailed information about the BR\*Tools parameters relevant for FlashCopy Manager control consult the *IBM Tivoli Storage FlashCopy Manager for AIX Installation and User's Guide for AIX*: [http://www-01.ibm.com/support/docview.wss?rs=4170&context=SS36V9&dc=DB550&dc=D420&dc=DB530&dc=D410&dc=DB510&dc=D430&q1=Installation&uid=swg24023932&loc=en\\_US&cs=utf-8&lang=en](http://www-01.ibm.com/support/docview.wss?rs=4170&context=SS36V9&dc=DB550&dc=D420&dc=DB530&dc=D410&dc=DB510&dc=D430&q1=Installation&uid=swg24023932&loc=en_US&cs=utf-8&lang=en)

## 4 FlashCopy Manager Installation and Configuration

IBM Tivoli Storage FlashCopy Manager must be installed on the production system. Optionally, it can also be installed on the backup system. The IBM Tivoli Storage FlashCopy Manager installation directory is /usr/tivoli/tsfcm/acs\_2.1.x.x. To install FlashCopy Manager with a graphical wizard, an X server has to be installed on the production system. For this setup a VNC server was used (see <http://www.tightvnc.com/>).

The installation package is using the following name format: <version>-TIV-TSFCM-<OS-platform>.bin

### 4.1 Software Installation

The installation of FlashCopy Manager is done rather quickly. There are three possible modes for the installation:

**GUI mode:** This requires a running X-Server. `./2.1.0.0-TIV-TSFCM-AIX.bin`

**Console mode:** Offers same features as GUI mode `./2.1.0.0-TIV-TSFCM-AIX.bin -i console`

**Silent mode:** An unattended setup requires a properties file. `./2.1.0.0-TIV-TSFCM-AIX.bin -i -f <properties_file>`

The main steps of the FlashCopy Manager installation are shown in Figure 11.

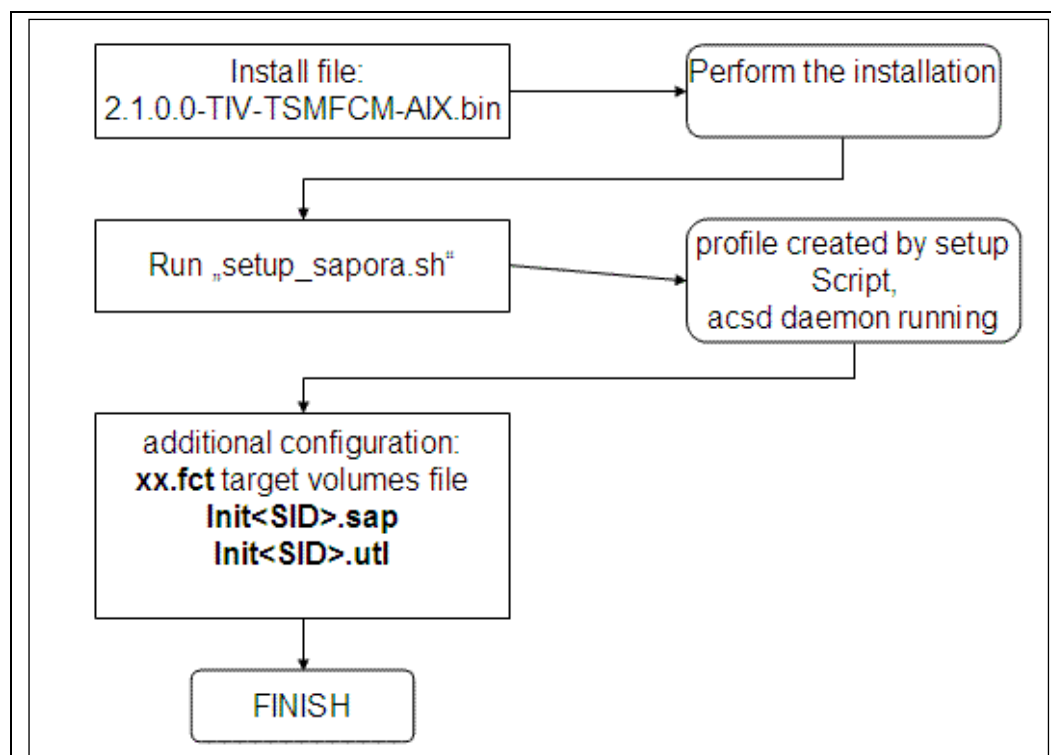

Figure 11: Installation/configuration workflow overview

The installation must be performed as root user.

1. Log on to the production server as root user
2. Using the GUI mode, enter `./2.1.0.0-TIV-TSFCM-AIX.bin`

3. Follow the instruction that are displayed
4. Check the summary of the install wizard, as shown in Figure 12. Be sure to enter the correct instance id of the database.

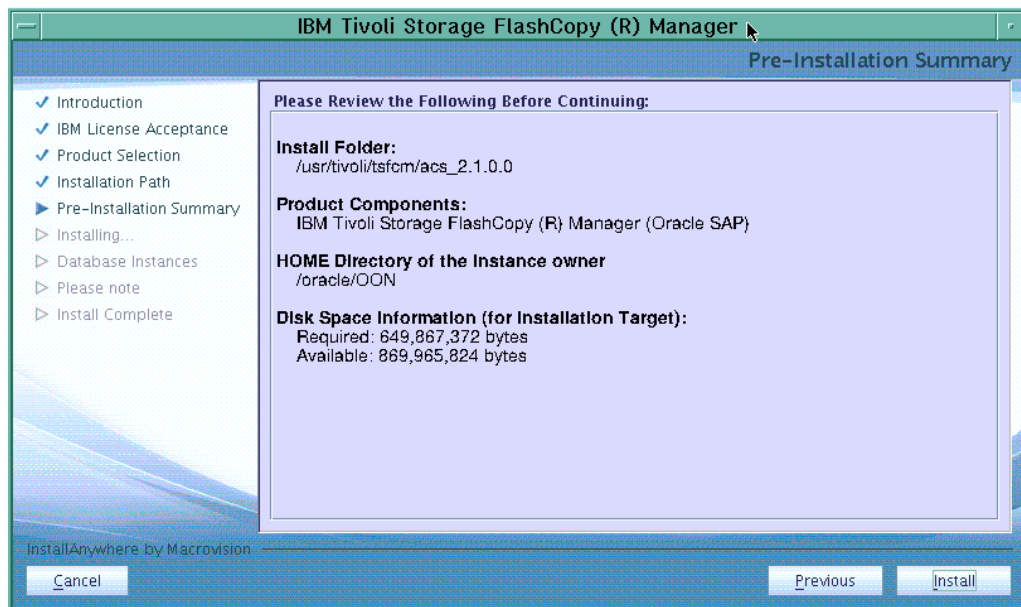

Figure 12: Pre-installation summary

After the installation has finished log into the server as the database owner and start the script `setup_sapora.sh`. This script asks a lot of setup questions that are described in the next chapter.

## 4.2 Configuration for disk only backup

After the installation of FlashCopy Manager a profile is required to successfully run FlashCopy Manager. In the following example FlashCopy Manager is configured for executing a backup to disk only. To create the profile login as the database instance owner and run the script `setup_sapora.sh` on the production system. The script asks several questions for the content of the profile. The main questions are:

- Configuration from PS or BS?
  - PS: FlashCopy Manager is configured from PS with subsequent remote deployment to BS via SSH. This is the recommended configuration
  - BS: This option is required if no SSH is available or no NFS share is possible
- Please enter the directory where the profile will be stored:
  - `/oracle/<SID>/acs`
- Are you going to perform off-loaded backups to Tivoli Storage Manager?
  - NO: Sections and parameters related to offloaded backups are omitted
- Path of the IBM Tivoli Storage FlashCopy(R) Manager directory {ACS\_DIR}
  - `/oracle/<SID>/acs`
- Hostname and port of machine running Management Agent {ACSD} (<hostname> <port>)
  - <hostname of the production server> 57328
- Path to the repository directory {ACS\_REPOSITORY}
  - `/oracle/<SID>/acs/acsrepository`

The Appendix shows complete `setup_sapora.sh` protocols for XIV and DS8000 storage systems. The setup script creates the profile in the `/oracle/<SID>/acs` directory and adds the CLIENT section for disk only backup to the profile. After the `setup_sapora.sh` script has run successfully, a target volumes file has to be created for DS8000 or SAN Volume Controller in the `acs` directory. FlashCopy Manager requires that the target volumes are defined in a file. For the XIV a target set definition is not necessary because the snapshots are created during the backup with FlashCopy Manager.

The name of the target volume file has the ending `.fct` and is specified during the execution of the setup script. The target volumes file contains the LUN IDs of the DS8000 or volume names of the SVC, see Figure 13. This example shows the target set for a DS8000.

```

>>> TARGET_SET volumes_set_1
TARGET_VOLUME 75819914F20 - -
TARGET_VOLUME 75819914E20 - -
TARGET_VOLUME 75819914E21 - -
TARGET_VOLUME 75819914F21 - -
TARGET_VOLUME 75819914E22 - -
TARGET_VOLUME 75819914F22 - -
<<< volumes_set_1

```

Figure 13: DS8000 target set definition file

In case of a diskonly backup, the database administrator has to take care of the offline redo logs. They are not automatically backed up by FlashCopy Manager. SAP's *brarchive* which is part of the BR\*Tools can be used to backup the offline redo logs.

Independent of the backup type that will be used, the system administrator also has to take care when backing up the FlashCopy Manager repository (*/oracle/<SID>/acs/acsrepository*). This directory contains the *cntrl<sid>.dbf* files and the backup history of FlashCopy Manager. In case of a server crash, the repository has to be restored.

### 4.3 Switching from diskonly to offloaded backup

If FlashCopy Manager was already installed and configured on the system without the offload backup option, it is recommended to rerun the *setup\_sapora.sh* script in order to modify the FlashCopy Manager profile instead of changing the configuration files manually.

Example:

```

Preparing to install on Production System
Found profile /oracle/OON/acs/profile
Do you want to:
  (c)reate a new profile
  (r)euse the profile unchanged
  (m)odify the profile
Please enter one of the strings in parentheses:
m
The management daemon seems to be running.
Do you want me to stop it to proceed with the configuration? [Y/N]
y
Stopping FCM management daemon on your request.
Deactivating FCM management daemon.
Currently off-loaded backups are not configured. Do you want to configure off-loaded backups? [y/n]
y

```

The setup script removes the CLIENT section from the FlashCopy Manager profile and adds a new section named OFFLOAD. In other words: the profile section CLIENT exists only if offload backup is not configured.

The information from the CLIENT section must be manually copied to the *backint* configuration file *init<SID>.utl* because "TSM for ERP Systems" will be used to transfer the data from the backup system to the TSM Server.

"TSM for ERP Systems" is called by SAP's BR\*Tools for backup and restore activities. Thus required in the BR\*Tools configuration file *init<SID>.sap* a link is required that points to the *backint/TSM for ERP* configuration file.

Example:

```
/oracle/OON/102_64/dbs/initOON.sap:
```

```
    util_par_file = initOON.utl
```

```
/oracle/OON/102_64/dbs/initOON.utl:
```

```
    # FlashCopy Manager offload backup section
    TARGET_DATABASE_SUSPEND YES
    TSM_BACKUP_FROM_SNAPSHOT YES
    MAX_SNAPSHOT_VERSIONS 3
    ACSD sapr3ora 57328
    ACS_DIR /oracle/OON/acs
```

The Appendix shows complete setup\_sapora.sh protocols for XIV and DS8000 storage systems.

Note: For offload backups of a SAP system with an Oracle or DB2 database to a TSM Server, the Tivoli software product “IBM Tivoli Storage Manager for Enterprise Resource Planning (TSM for ERP)” must be installed on the backup server. It is possible to access the production system’s configuration files on the backup system via NFS to ease maintenance.

Example:

```
# df -g
Filesystem  GB blocks   Free %Used   lused %lused Mounted on
/dev/hd4    1.22    0.31  75%   3958    6% /
...
sapr3ora:/oracle/OON/102_64  30.00    8.48  72%   74972    4% /oracle/OON/102_64
```

Special note for XIV: XIV does not pre-allocate space for a snapshot. Thus an existing snapshot must be mapped to the backup server “on the fly” in order to access the XIV volumes. FlashCopy Manager currently expects the backup server’s hostname and the backup’s server name on XIV to be identical. If this requirement is not matched, FlashCopy Manager will display an error message like:

```
MNT 21:15:28 (a36) FMM6981E Received an error from the adapter:
during doMount(): Backuphost "sapr3oracl" is not defined in your XIV storage system.
```

## 5 Backup/Restore scenarios

This chapter describes basic backup and restore scenarios that are supported by FlashCopy Manager. For the examples tested at the IBM lab the following information is provided:

- the command line to invoke the backup or restore
- output information required for follow-on activities (e.g. backup IDs required for a potential restore)

Figure 14 and Figure 15 show the backup and restore options of FlashCopy Manager:

1. a diskonly backup of the production environment leveraging the FlashCopy or Snapshot feature of the storage system
2. a backup server offloading the database backup on the FlashCopy target volumes to a TSM server
3. a restore of the diskonly backup to the production environment reversing an existing FlashCopy or Snapshot
4. a restore from the TSM server to the production environment

Notes:

- For a diskonly backup or restore neither a backup server nor a TSM server is required (scenarios 1 and 3).
- A TSM restore writes directly to the production environment (scenario 4).
- The TSM server can be installed on the backup server.
- An online or offline database backup with SAP's `brbackup` utility that transfers the data directly to a TSM Server is still possible in the production environment (but not shown in the figures). In this case `brbackup` can be started with a device type unequal `util_vol` e.g. `disk`, `tape`, `util_file`.

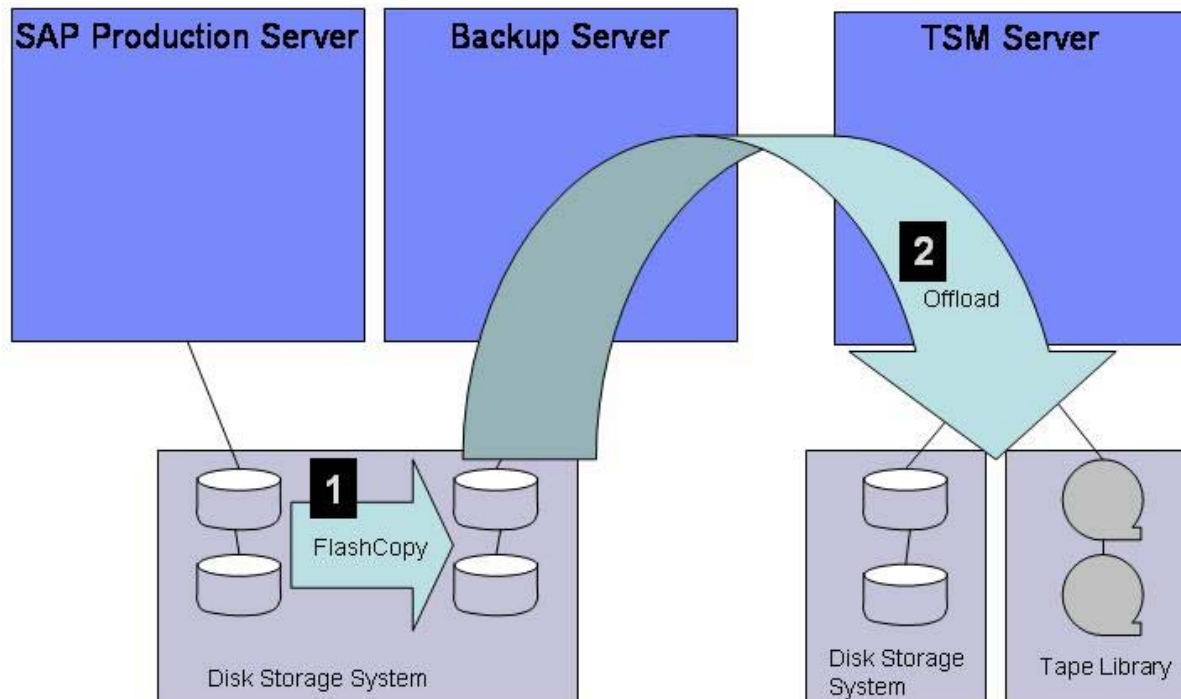

Figure 14: Backup options of FlashCopy Manager

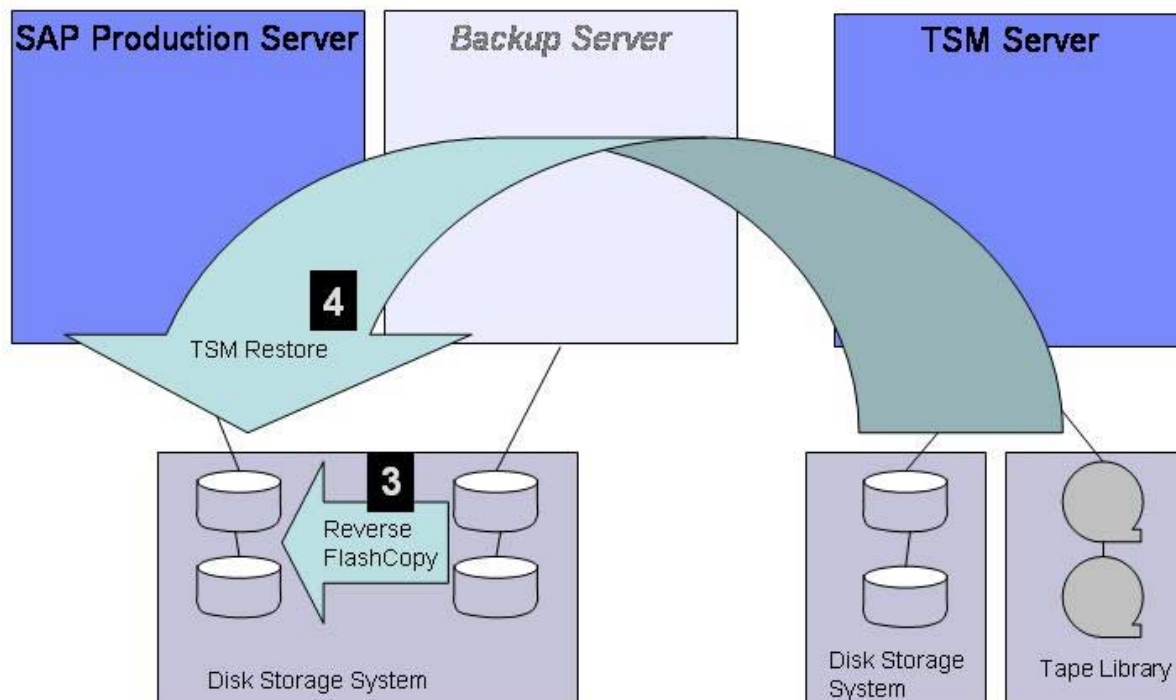

Figure 15: Restore options of FlashCopy Manager

### 5.1 Diskonly Backup

A diskonly backup leverages the point-in-time copy functionality of the storage subsystem to create copies of the LUNs that host the database. A diskonly backup requires neither a backup server nor a TSM server.

A diskonly backup is initiated with SAP's *brbackup* command using the device type *util\_vol*.

Command line example:

```
# su - oraoon
$ cd acs
$ brbackup -d util_vol -u system/password
```

Remark: If the parameter *backup\_dev\_type* is set to *util\_vol* in the configuration file *init<SID>.sap*, the option “-d” is not required in the *brbackup* command.

Required parameters in the FlashCopy Manager profile *<ACS\_DIR>/profile*:

For an online backup of an Oracle database, SAP's *brbackup* utility puts the database in backup mode. FlashCopy Manager can be configured to suspend database activity or freeze file system I/O during the FlashCopy or Snapshot operation. These additional functions are controlled by the FlashCopy Manager profile parameters *TARGET\_DATABASE\_SUSPEND* and *LVM\_FREEZE\_THAW*. These two parameters are interdependent e.g. a database that resides on JFS file systems must be suspended before freezing the file systems.

These two profile parameters are mandatory. If not set, the *brbackup* detail log will contain appropriate error messages e.g.

FMM8307E The parameter *TARGET\_DATABASE\_SUSPEND* must be specified in the profile.



Check the FlashCopy Manager Installations and User's Guide for more detailed information.

FlashCopy Manager creates a BackupID that is displayed in the backup log file and can also be read out with the *acsutil* or *backint* tools. This BackupID or an equivalent SnapshotID will be required to initiate a restore.

The BackupID is a string of 10 alpha-numeric characters appended to the SAP SystemID (SID) e.g. A0G1EYJKQ7.

Note that additional IDs are created for the backups of the database control files, the backup log files and the associated configuration files *init<SID>.\**. These two backups are automatically initiated after a successful database backup with the SAP utility *brbackup*.

Examples:

(1) Backup log file in */oracle/<SID>/sapbackup*:

```
BR0280I BRBACKUP time stamp: 2009-10-30 13.06.12
#FILE..... /oracle/OON/sapdata1/system_1/system.data1
#SAVED.... OON___A0G1EYJKQ7
```

(2) *acsutil* command line:

```
# su - oraoon
$ cd acs
$ ./acsutil -p /oracle/OON/acs/profile
```

(3) *backint* command line:

```
$ backint -p /oracle/OON/102_64/dbs/initOON.utl -t volume -f inquire_detail
```

...

Please enter the records for function 'inquire' :

```
{ <backup_id1> | #NULL } [ <file1> ]
```

```
[ <backup_id2> | #NULL [ <file2> ] ]
```

(Press ENTER after each record / line. Press CTRL-D to finish the list.)

```
#NULL
```

...

```
#BACKUP OON___A0G19IDLGN IN_PROGRESS -
```

```
TARGET_SET=volumes_set_1,REMOTELY_MOUNTABLE,REPETITIVELY_RESTOREABLE,SWAP_
RESTORABLE,PHYSICAL_PROTECTION,FULL_COPY,BACKGROUND_MONITOR_PENDING (
240.000 GB of 240.000 GB )
```

...

```
FMM0024I Return code is: 0.
```

The XIVGUI snapshot in Figure 16 shows multiple sequenced XIV snapshots created by FlashCopy Manager. XIV allocates snapshot space at the time it is required.

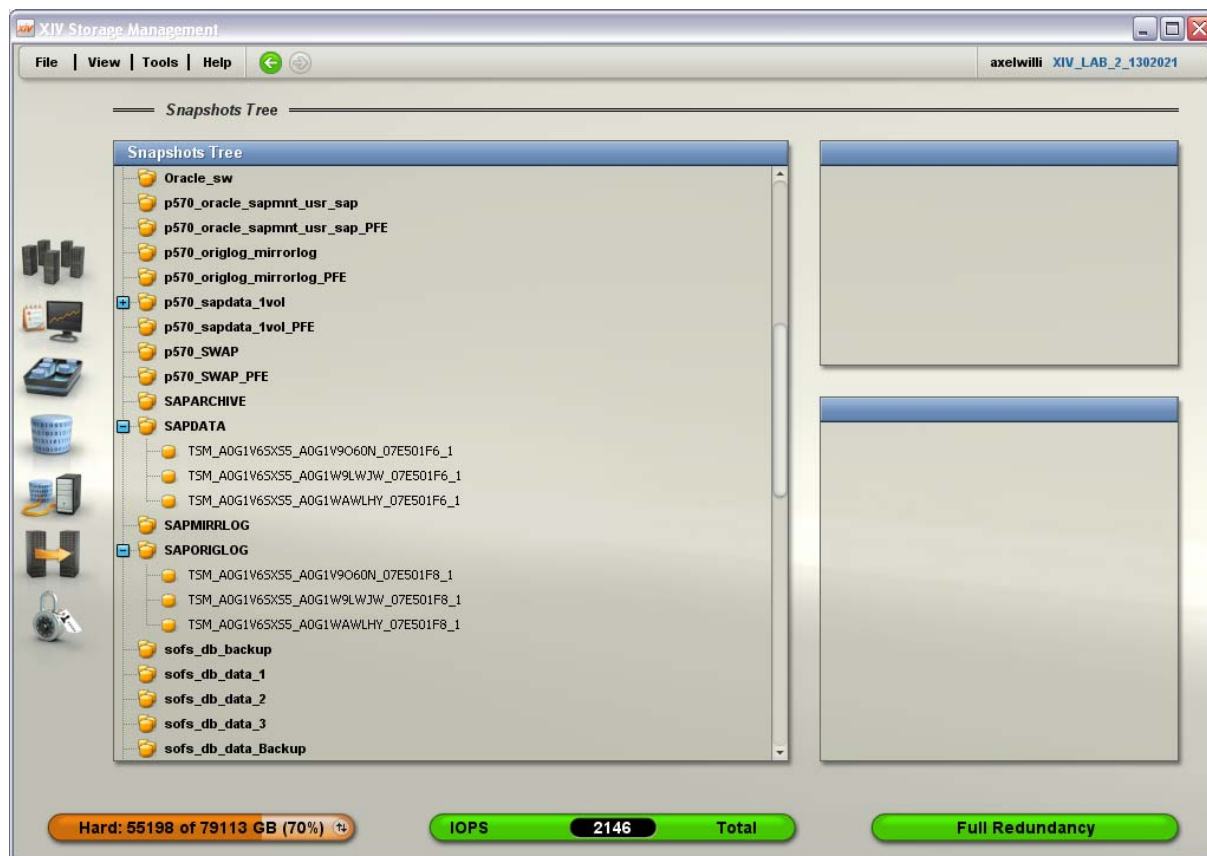

Figure 16: XIV snapshots created by FlashCopy Manager

Check that enough XIV snapshot space is available for the number of snapshot versions to keep. If snapshot space is not sufficient, XIV starts to delete older snapshot versions. These deletions are not immediately reflected in FlashCopy Manager's repository. FlashCopy Manager's interval for reconciliation is specified during FlashCopy Manager setup and can be checked and updated in the FlashCopy Manager profile. The current default of the RECON\_INTERVAL parameter is 12 hours.

## 5.2 Offload to Tivoli Storage Manager

An existing diskonly backup can be offloaded to a TSM server. A backup server accesses the data on the FlashCopy target volumes and forwards the data to a TSM server which in-turn stores it in one of its storage pools (tape or disk).

FlashCopy Manager supports multiple FlashCopy targets enabling the creation of several backup versions. Nevertheless a diskonly backup will usually be overwritten in shorter intervals than a TSM backup which will usually be kept for weeks. On a DS8000 and an SVC, FlashCopy target volumes must be pre-allocated while an XIV requires disk space for a snapshot only when it is required which can make diskonly backup versioning on XIV less expensive.

An existing diskonly backup must be in the status TAPE\_BACKUP\_PENDING in order to offload it to a TSM server. Snapshot backups must be created with the flag TAPE\_BACKUP\_FROM\_SNAPSHOT already to prepare a subsequent tape backup. This flag must be specified either as part of the backup command or as a profile parameter, thus applying to all backups.

The parameter is specified in the TSM for ERP Systems profile init<SID>.utl:  
 TAPE\_BACKUP\_FROM\_SNAPSHOT YES|NO

Before or after performing an offload to TSM, the *backint* utility displays the FlashCopy Manager backup status.

Example:

```
sapr3ora:oraon 51> backint -f inquire_detail -t volume -p /oracle/OON/102_64/dbs/initOON.utl
```

#### Data Protection for SAP(R)

Interface between BR\*Tools and Tivoli Storage Manager  
 - Version 6, Release 1, Modification 0.0 for AIX LF 64-bit -  
 Build: 358 compiled on Nov 4 2008  
 (c) Copyright IBM Corporation, 1996, 2008, All Rights Reserved.

#### IBM Tivoli Storage FlashCopy(R) Manager for SAP(R)

Interface between BR\*Tools and IBM Tivoli Storage FlashCopy(R) Manager  
 - Version 2, Release 1, Modification 0.0 for AIX LF 64-bit -  
 Build: 427 compiled on Sep 29 2009  
 (c) Copyright IBM Corporation, 1996, 2009, All Rights Reserved.

Please enter the records for function 'inquire' :

```
{ <backup_id1> | #NULL } [ <file1> ]
```

```
[ <backup_id2> | #NULL [ <file2> ] ]
```

(Press ENTER after each record / line. Press CTRL-D to finish the list.)

```
#NULL
```

```
FMM8300I tsmACSInitialize() returned with code 0.
```

```
FMM8300I tsmACSBeginQuery() returned with code 0.
```

```
FMM8300I tsmACSGetNextObject() returned with code 21 (More data available).
```

```
FMM8300I tsmACSGetNextObject() returned with code 21 (More data available).
```

```
FMM8300I tsmACSGetNextObject() returned with code 21 (More data available).
```

```
FMM8300I tsmACSGetNextObject() returned with code 21 (More data available).
```

```
FMM8300I tsmACSGetNextObject() returned with code 14 (End of data reached).
```

```
FMM8300I tsmACSEndQuery() returned with code 0.
```

```
#BACKUP OON___A0G1WL7NSM IN_PROGRESS -
```

```
REPETITIVELY_RESTOREABLE,TAPE_BACKUP_PENDING,MOUNTING ( 0 Bytes of 0 Bytes )
```

```
#BACKUP OON___A0G1WAWLHY SUCCESSFUL - REPETITIVELY_RESTOREABLE ( 0 Bytes of 0 Bytes )
```

```
#BACKUP OON___A0G1W9LWJW SUCCESSFUL - REPETITIVELY_RESTOREABLE ( 0 Bytes of 0 Bytes )
```

```
#BACKUP OON___A0G1V6WVC5 FAILED - REPETITIVELY_RESTOREABLE,MOUNTING ( 0 Bytes of 0 Bytes )
```

```
FMM8300I tsmACSTerminate() returned with code 0.
```

```
FMM0020I End of program at: Wed Nov 11 21:17:14 Europe 2009 .
```

```
FMM0021I Elapsed time: 01 sec .
```

```
FMM0024I Return code is: 0.
```

```
sapr3ora:oraon 52>
```

The IBM Tivoli Storage FlashCopy Manager offload agent will pick up all snapshot backups in the state TAPE\_BACKUP\_PENDING and back them up to tape.

The offload of an existing backup to TSM is initiated with the tsm4acs utility using the option "-f tape\_backup". A BackupID or SnapshotID can be specified with the options "-B" and "-T".

Command line examples:

```
# su - oraon
```

```
$ cd acs
```

```
$ tsm4acs -f tape_backup
```

```
or
```

```
$ tsm4acs -f tape_backup -d OON
```

```
or
```

```
$ tsm4acs -f tape_backup -d OON -B A0G1EYJKQ7
```

or  
 \$ tsm4acs -f tape\_backup -d OON -T 20090819094306

### 5.3 Restore from Snapshot

A diskonly backup can be restored with SAP's *brrecover* utility. Snapshots are done on a volume group level. In other words: the storage-based snapshot feature is not aware of the database and file systems structures and cannot perform restore operations on the file or table space level. Only the volume groups are backed up and restored by FlashCopy Manager.

SAP's *brrecover* is a menu-driven utility that decides after each step about potential follow-on steps. If only a partial restore is required, *brrecover* finds faults with the restoration of files which were not missing in the preceding check. This is an unavoidable result of the snapshot reverse. Appropriate error messages should be carefully evaluated (which should always be the case in a restore activity) - if applicable - can be ignored in the next step of the *brrecover* run.

Example: A data file of the Oracle SYSTEM table space is missing.

Run *brrecover*

```
# su - oraon
$ brrecover
```

```
1 = Check the status of database files
2 * Select database backup
3 * Restore split/standby control files
4 * Restore data files
5 * Restore split incremental control files
6 * Restore and apply incremental backup
7 * Restore and apply archivelog files
8 * Open database and post-processing
9 * Exit program
10 - Reset program status
```

The status check discovers that the file system.data1 is missing:

```
SYSTEM      UNKNOWN  /oracle/OON/sapdata1/system_1/system.data1    RECOVER    1
367001600* 2008-11-20 16.40.15          5          0 NULL NOLINK
```

BR0758I Data file '/oracle/OON/sapdata1/system\_1/system.data1' not found - it will be restored/recreated and recovered

*brrecover* offers available database backups for restore. The device type *util\_vol* shows that these are FlashCopy or Snapshot backups:

Database backups for complete database recovery

Pos.	Log	Start	Type	Mode	Device	Rc	UVol1/Stat.
1	= bebucipe.afv	2009-10-28 10.15.54	offline	all	util_vol	0	<part_conf>+<part_conf>
2	- bebtyrzo.afv	2009-10-27 16.30.04	offline	all	util_vol	0	<not_conf>+<part_conf>

The selection of the most recent backup (1) results in the following actions:

- File system unmount and volume group export
- FlashCopy reverse
- Volume group import and file system mount

```

FMM0568I Removing volume group sapdatavg ....
FMM0569I Varied off and exported volume group : sapdatavg
FMM4183I Performing INCR reverse FlashCopy of source volume 75819914508 to target volume
75819914F20.
FMM4183I Performing INCR reverse FlashCopy of source volume 75819914408 to target volume
75819914E20.
FMM0643I Executing system command 'importvg -V 34 -y sapdatavg -n hdisk6 '
FMM0591I Bringing up the volume groups...
FMM0543I Mounting filesystem : /oracle/OON/sapdata1.
FMM0543I Mounting filesystem : /oracle/OON/sapdata2.
FMM0543I Mounting filesystem : /oracle/OON/sapdata3.
FMM0543I Mounting filesystem : /oracle/OON/sapdata4.

```

*brrecover* displays an error message for all restored file systems except system.data1 which was missing in fact:

```
BR0376E Unknown file '/oracle/OON/sapdata3/sr3700_3/sr3700.data3' restored by backup utility
```

```
BR0668I Warnings or errors occurred - you can continue to ignore them or go back to repeat the last action
```

The recovery process can continue applying archive and redo log files and opening the database. The final *brrecover* message should look like this:

```
BR0703I BRRECOVER completed successfully with warnings or non-fatal errors
```

## 5.4 Backup and Restore from TSM Server

Backup and restore to and from a TSM server are not specific to FlashCopy Manager. This means that the *brbackup* and *brrecover* utilities are used with appropriate backup types like *online* or *offline* as if FlashCopy Manager was not installed.

## 5.5 Additional functions

The *tsm4acs* utility with the option “-f mount” can be used to access the database on the FlashCopy targets volumes from the backup server without offloading the data to a TSM server. A possible use can be the creation of a new SAP environment for testing purpose. The access can be terminated with “*tsm4acs*” using the option “-f unmount”.

Examples:

```

# su - oraon
$ cd acs
$ tsm4acs -f mount -d OON -T 20090819094306
or
$ tsm4acs -f mount

```

```

$ lsvg -o
OONtdp3
OONtdp2
OONtdp1
sapswvg
saparchvg
swapvg
rootvg

```

```
$ tsm4acs -f unmount -d OON  
  or
```

```
$ tsm4acs -f unmount -F
```

```
# "-F": FORCE option
```

## 6 Backup schedule options

Multiple options are possible to schedule a backup operation e.g.

- a *crontab* entry on UNIX
- a Tivoli Storage Manager schedule
- an entry in SAP's DBA planning calendar (SAP transaction DB13 or DBACOCKPIT, see Figure 17 )

Note that the planning calendar's ability to specify command line options is limited. BR\*Tools' command line options overwrite the values in the BR\*Tools profile *init<SID>.sap*. This means that the profile must include all required *brbackup* parameters.

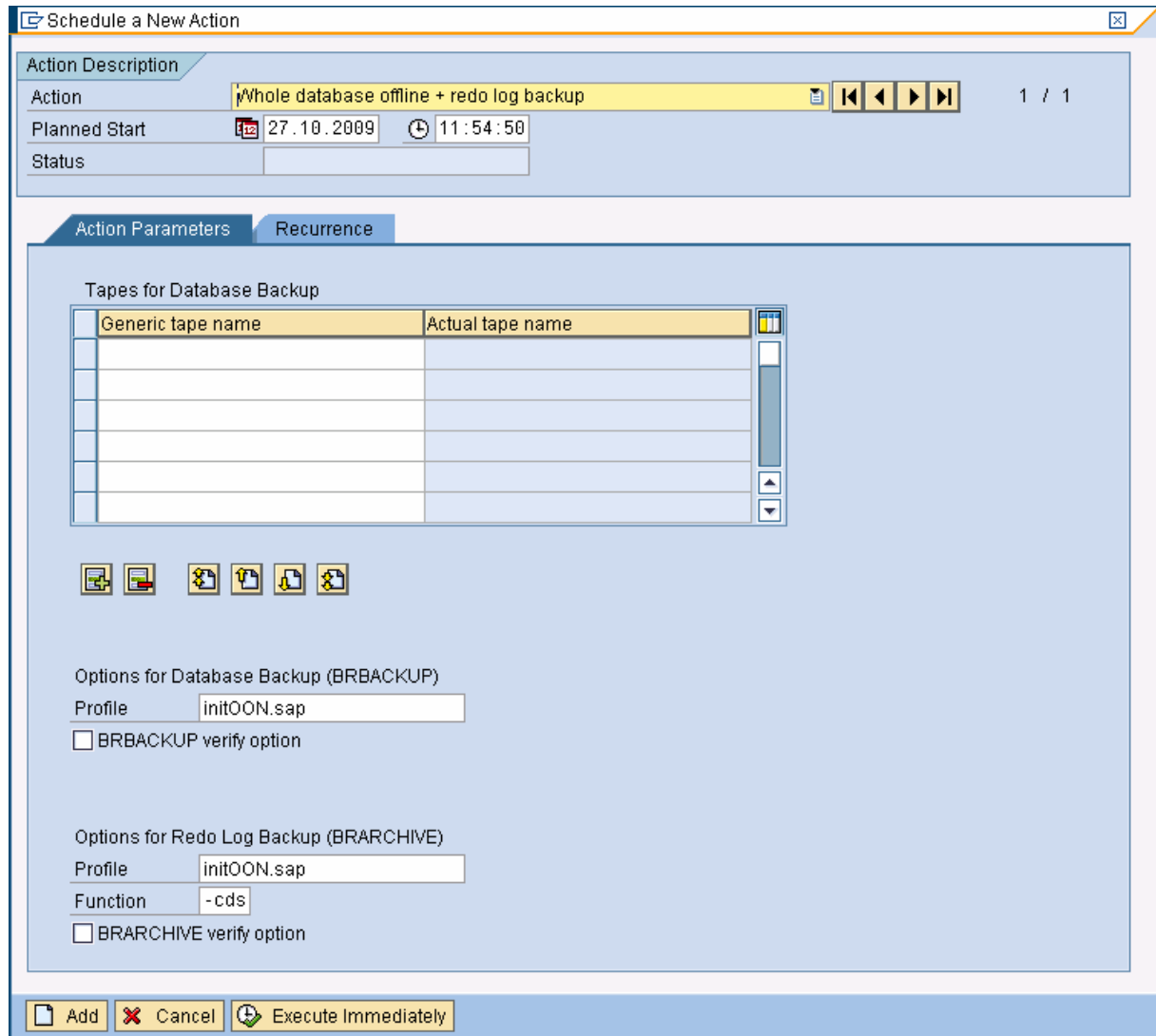

Figure 17: SAP's DBA planning calendar

This is a rudimental example how to schedule a backup using SAP's *brbackup* utility with UNIX onboard tools.

Example:

Step 1: create a shell script that calls *brbackup*

```
sap3ora:oraon 3> cat mybrbackup.sh
```

```
#!/bin/ksh
su - orapro << EOF
brbackup -d util_vol -u system/password
EOF
sapr3ora:oraoon 4>
```

Step 2: create a crontab entry that schedules the shell script at a specified time  
(here: each weekday at 15 minutes before midnight)

```
sapr3ora:root > cat /var/spool/cron/crontabs/root
...
45 23 * * * /oracle/OON/mybrbackup.sh 1>/oracle/OON/mybrbackup.log 2>&1
...
```



## 7 Appendix

The appendix shows three different protocols of a FlashCopy Manager setup using the `setup_sapora.sh` script:

1. FlashCopy Manager setup for XIV
2. FlashCopy Manager setup for XIV with offload backup
3. Initial FlashCopy Manager setup for DS8000

The sections that are specific to a storage system are indicated in blue colour. In these examples the storage-specific DEVICE CLASS is named STANDARD. FlashCopy Manager needs the password of the storage system user to control the box via CIM or command line interface. The passwords are specified in a subsequent section. The question "Do you want to continue by specifying passwords for the defined sections?" must be answered with "yes" to enter this section.

### 7.1 Setup script protocol for SAP/Oracle on IBM XIV

```
sapr3ora:ora00n 8> cd /oracle/OON/acs/
sapr3ora:ora00n 9> ./setup_sapora.sh
```

```
checking /oracle/OON/acs/acsgen ...
OK
```

Select one of these configurations:

- (1) On-Site Production System configuration with optional remote Backup System configuration
- (2) On-Site Backup System configuration

Enter '1' to configure IBM Tivoli Storage FlashCopy(R) Manager on the production server with the option to remotely synchronize the configuration of one or multiple backup systems using Secure Shell.

Enter '2' to configure IBM Tivoli Storage FlashCopy(R) Manager on the backup system as a 'separate installation'.

```
1
```

Preparing to install on Production System

Found profile /oracle/OON/acs/profile

Do you want to:

- (c)reate a new profile
- (r)euse the profile unchanged
- (m)odify the profile

Please enter one of the strings in parentheses:

```
c
```

Successfully created backup of current profile: /oracle/OON/acs/profile.bkp.20091110150937.

Deactivating FCM management daemon.

Are you going to perform off-loaded backups to Tivoli Storage Manager? [y/n]

```
n
```

Welcome to new wizard!

Special commands:

'?' -> Show help for current parameter

'!d' -> Delete current parameter instance (only applicable to multi-instance parameters)

FMM8422I Creating new profile '/oracle/OON/acs/profile' for application 'SAP\_ORACLE' ...

\*\*\*\*\* Profile parameters for section GLOBAL : \*\*\*\*\*

Path of the IBM Tivoli Storage FlashCopy(R) Manager directory {ACS\_DIR} = [/oracle/OON/acs]

Hostname and port of machine running Management Agent {ACSD} (<hostname> <port>) = [sapr3ora 57328]

Low level tracing {TRACE} (YES|NO) = [NO]

\*\*\*\*\* Profile parameters for section ACSD : \*\*\*\*\*

Path to the repository directory {ACS\_REPOSITORY} = \*input mandatory\* /oracle/OON/acs/acsrepository

Support for Administration Assistant {ADMIN\_ASSISTANT} (<hostname> <port>|NO) = [NO]

Prefix for volume names {REPOSITORY\_LABEL} = [TSM]

\*\*\*\*\* Profile parameters for section CLIENT : \*\*\*\*\*

Identifier for backups of this database instance in the repository {BACKUPIDPREFIX} (<string>) = [SAP\_\_]

Suspend target database {TARGET\_DATABASE\_SUSPEND} (NO|YES|OFFLINE) = \*input mandatory\* YES

Maximum number of snapshot versions {MAX\_VERSIONS} (<number>|ADAPTIVE) = [ADAPTIVE]

Freeze/thaw filesystem {LVM\_FREEZE\_THAW} (YES|NO|AUTO) = [AUTO]

Timeout {TIMEOUT\_FLASH} for phase 'flash' (<in seconds>) = [120]

Device class(es) {DEVICE\_CLASS} (<list of dev classes> [USE\_AT <weekdays>] [FROM <time> TO <time>]) = [STANDARD]

\*\*\*\*\* Profile parameters for section DEVICE\_CLASS STANDARD: \*\*\*\*\*

```
Type of Storage system {COPYSERVICES_HARDWARE_TYPE} (DS8000|SVC|XIV) = *input mandatory*   XIV
Storage system ID of referred cluster {STORAGE_SYSTEM_ID} = [] 2021
Filepath to XCLI command line tool {PATH_TO_XCLI} = *input mandatory* /oracle/xcli/XIVGUI
Hostname of XIV system {COPYSERVICES_SERVERNAME} = *input mandatory* 9.155.86.220
Username for storage device {COPYSERVICES_USERNAME} = [superuser] axelwilli
Interval for reconciliation {RECON_INTERVAL} (<hours>) = [12]
Grace period to retain snapshots {GRACE_PERIOD} (<hours>) = [24]
Use writable snapshots USE_WRITABLE_SNAPSHOTS (YES|NO|AUTO) = [AUTO]
Use consistency groups USE_CONSISTENCY_GROUPS (YES|NO) = [YES]
Hostname of backup host {BACKUP_HOST_NAME} = [] sapr3oracl
```

```
FMM8426I Saving profile '/oracle/OON/acs/profile' ...
FMM1555I Profile successfully created.
```

Do you want to continue by specifying passwords for the defined sections? [Y/N]  
Y

Please enter the password for authentication with the ACS daemon: [\*\*\*]

Please enter the password for device section STANDARD: [\*\*\*]

→ Enter the XIV user's password here!

```
FMM8437I Verifying password...
FMM0005I Start of program at: Thu Nov 10 15:19:50 Europe 2009 .
FMM0020I End of program at: Thu Nov 10 15:20:05 Europe 2009 .
FMM0021I Elapsed time: 15 sec .
FMM6959I Script '/oracle/xcli/XIVGUI/jre/bin/java -classpath /oracle/xcli/XIVGUI/lib/*:/oracle/OON/acs/XivAdapter.jar
com.ibm.storage.xiv.XivAdapter -x /oracle/xcli/XIVGUI/ -f checkpw' returned with code 0.
```

Creating password file at /oracle/OON/acs/shared/pwd.acsd.  
A copy of this file needs to be available to all components that connect to acsd.

IBM Tivoli Storage FlashCopy(R) Manager requires at least two daemon processes to be running at all times. The management daemon (acsd) and the generic device agent (acsngen) are typically registered in the /etc/inittab on the production server by the configuration wizard. Both daemon processes restart after a system reboot. If installing in a High Availability environment, both daemon processes must be started from the High Availability environment. If you specify YES, these two daemon processes are not be added to the /etc/inittab and the required executable files and command-line options display. Make sure these two daemon processes are started by the High Availability scripts. If you specify NO, /etc/inittab is used.

Do you want to install in a High Availability environment? [Y/N]  
N

Do you want to update the Backup System installation on sapr3oracl? [Y/N]  
N

A backup system must be installed and configured when off-loaded backups to Tivoli Storage Manager are performed or when FlashCopy backup consistency verification is needed during a forced mount. Note that remote connections from the production system to the backup system must already exist to use Open SSH. Specify YES to use OpenSSH. When prompted to specify which DEVICE\_CLASS should be enabled on the backup system, either select from the list of available DEVICE\_CLASS parameters or press Enter to select all listed DEVICE\_CLASS parameters. Specify NO if OpenSSH is not available, the INST\_DIR and ACS\_DIR use NFS to share between the production system and backup system, or you want to configure the backup system in a separate step.

Do you want to install a new Backup System using the Open Secure Shell (OpenSSH) protocol? [Y/N]  
N

sapr3ora:oraoon 10>

## 7.2 Setup script protocol for SAP/Oracle on IBM XIV incl. Offload to TSM Server

sapr3ora:oraoon 12> ./setup\_sapora.sh

checking /oracle/OON/acs/acsngen ...  
OK

Select one of these configurations:

(1) On-Site Production System configuration with optional remote Backup System configuration  
 (2) On-Site Backup System configuration  
 Enter '1' to configure IBM Tivoli Storage FlashCopy(R) Manager on the production server with the option to remotely synchronize the configuration of one or multiple backup systems using Secure Shell.  
 Enter '2' to configure IBM Tivoli Storage FlashCopy(R) Manager on the backup system as a 'separate installation'.

```
1
Preparing to install on Production System
Found profile /oracle/OON/acs/profile
Do you want to:
  (c)reate a new profile
  (r)euse the profile unchanged
  (m)odify the profile
Please enter one of the strings in parentheses:
m
The management daemon seems to be running.
Do you want me to stop it to proceed with the configuration? [Y/N]
y
Stopping FCM management daemon on your request.
Deactivating FCM management daemon.
Currently off-loaded backups are not configured. Do you want to configure off-loaded backups? [y/n]
y
After the configuration of the off-loaded backups, the CLIENT section will be removed from the profile.
If you want to review the settings of the Client section to configure the .utl file, please have a look at the profile with the .bck file name extension in the directory where the profile is stored.
Welcome to new wizard!

Special commands:
 '?' -> Show help for current parameter
 '!d' -> Delete current parameter instance (only applicable to multi-instance parameters)
```

FMM8421I Modifying existing profile '/oracle/OON/acs/profile' for application 'SAP\_ORACLE' ...

\*\*\*\*\* Profile parameters for section GLOBAL : \*\*\*\*\*

```
Path of the IBM Tivoli Storage FlashCopy(R) Manager directory {ACS_DIR} = [/oracle/OON/acs]
Hostname and port of machine running Management Agent {ACSD} (<hostname> <port>) = [sapr3ora 57328]
Low level tracing {TRACE} (YES|NO) = [NO]
```

\*\*\*\*\* Profile parameters for section ACSD : \*\*\*\*\*

```
Path to the repository directory {ACS_REPOSITORY} = [/oracle/OON/acs/acsrepository] /oracle/OON/acs/acsrepository
Support for Administration Assistant {ADMIN_ASSISTANT} (<hostname> <port>|NO) = [NO]
Prefix for volume names {REPOSITORY_LABEL} = [TSM]
```

\*\*\*\*\* Profile parameters for section OFFLOAD : \*\*\*\*\*

```
Fully qualified filename of external SAP(R) Backint profile (.utl file) {PROFILE} = *input mandatory*
/oracle/OON/102_64/dbs/initOON.utl
```

\*\*\*\*\* Profile parameters for section DEVICE\_CLASS STANDARD: \*\*\*\*\*

```
Type of Storage system {COPYSERVICES_HARDWARE_TYPE} (DS8000|SVC|XIV) = [XIV]
Storage system ID of referred cluster {STORAGE_SYSTEM_ID} = [2021]
Filepath to XCLI command line tool {PATH_TO_XCLI} = [/oracle/xcli/XIVGUJ]
Hostname of XIV system {COPYSERVICES_SERVERNAME} = [9.155.86.220]
Username for storage device {COPYSERVICES_USERNAME} = [axelwilli]
Interval for reconciliation {RECON_INTERVAL} (<hours> ) = [12]
Grace period to retain snapshots {GRACE_PERIOD} (<hours> ) = [24]
Use writable snapshots USE_WRITABLE_SNAPSHOTS (YES|NO|AUTO) = [AUTO]
Use consistency groups USE_CONSISTENCY_GROUPS (YES|NO) = [YES]
Hostname of backup host {BACKUP_HOST_NAME} = [sapr3oracl]
```

FMM8426I Saving profile '/oracle/OON/acs/profile' ...

FMM1555I Profile successfully created.

Please configure the TSM for ERP profile initOON.utl appropriately.

Do you want to continue by specifying passwords for the defined sections? [Y/N]

N

IBM Tivoli Storage FlashCopy(R) Manager requires at least two daemon processes to be running at all times.  
 The management daemon (acsd) and the generic device agent (acsngen) are typically registered in the /etc/inittab on the production server by the configuration wizard.  
 Both daemon processes restart after a system reboot.  
 If installing in a High Availability environment, both daemon processes must be started from the High Availability environment.

If you specify YES, these two daemon processes are not be added to the /etc/inittab and the required executable files and command-line options display.

Make sure these two daemon processes are started by the High Availability scripts. If you specify NO, /etc/inittab is used.

Do you want to install in a High Availability environment? [Y/N]

N

The off-loaded backup to Tivoli Storage Manager will be performed by the IBM Tivoli Storage FlashCopy(R) Manager offload agent 'tsm4acs'.

Specify YES to perform the off-loaded backup immediately after the FlashCopy backup completes. This adds 'tsm4acs' to the /etc/inittab.

The default is to run 'tsm4acs' as a daemon process on the production server.

In High Availability environments, no entry is made to /etc/inittab since 'tsm4acs' must be added to the High Availability script.

Specify NO to schedule off-loaded backups individually with a crontab entry.

Do you want off-loaded tape backups to begin immediately after the snapshot? [Y/N]

N

Do you want to update the Backup System installation on sapr3oracl? [Y/N]

Y

Enter the device classes to use for this Backup System. Make sure each device class is separated by a comma.

To use all defined device classes just hit enter.

root@sapr3oracl's password:

start copying...

copy completed.

start agents

Successfully updated the Backup System.

A backup system must be installed and configured when off-loaded backups to Tivoli Storage Manager are performed or when FlashCopy backup consistency verification is needed during a forced mount.

Note that remote connections from the production system to the backup system must already exist to use Open SSH.

Specify YES to use OpenSSH. When prompted to specify which DEVICE\_CLASS should be enabled on the backup system, either select from the list of available DEVICE\_CLASS parameters or press Enter to select all listed DEVICE\_CLASS parameters.

Specify NO if OpenSSH is not available, the INST\_DIR and ACS\_DIR use NFS to share between the production system and backup system,

or you want to configure the backup system in a separate step.

Do you want to install a new Backup System using the Open Secure Shell (OpenSSH) protocol? [Y/N]

N

sapr3ora:oraoon 13>

### **7.3 Setup script protocol for SAP/Oracle on IBM DS8000**

sapr3ora:oraoon 1> cd /oracle/OON/acs/

sapr3ora:oraoon 2> ./setup\_sapora.sh

checking /oracle/OON/acs/acsgen ...

OK

Select one of these configurations:

(1) On-Site Production System configuration with optional remote Backup System configuration

(2) On-Site Backup System configuration

Enter '1' to configure IBM Tivoli Storage FlashCopy(R) Manager on the production server with the option to remotely synchronize the configuration of one or multiple backup systems using Secure Shell.

Enter '2' to configure IBM Tivoli Storage FlashCopy(R) Manager on the backup system as a 'separate installation'.

1

Preparing to install on Production System

Please enter the directory where the profile will be stored: [/oracle/OON/acs]

selected profile path: /oracle/OON/acs

Deactivating FCM management daemon.

Are you going to perform off-loaded backups to Tivoli Storage Manager? [y/n]

y

Welcome to new wizard!

Special commands:

'?' -> Show help for current parameter

'ld' -> Delete current parameter instance (only applicable to multi-instance parameters)

FMM8422I Creating new profile '/oracle/OON/acs/profile' for application 'SAP\_ORACLE' ...

\*\*\*\*\* Profile parameters for section GLOBAL : \*\*\*\*\*

Path of the IBM Tivoli Storage FlashCopy(R) Manager directory {ACS\_DIR} = [/oracle/OON/acs]  
 Hostname and port of machine running Management Agent {ACSD} (<hostname> <port>) = [sapr3ora 57328]  
 Low level tracing {TRACE} (YES|NO) = [NO]

\*\*\*\*\* Profile parameters for section ACSD : \*\*\*\*\*

Path to the repository directory {ACS\_REPOSITORY} = \*input mandatory\* /oracle/OON/acs/acsrepository  
 Support for Administration Assistant {ADMIN\_ASSISTANT} (<hostname> <port>|NO) = [NO]  
 Prefix for volume names {REPOSITORY\_LABEL} = [TSM]

\*\*\*\*\* Profile parameters for section OFFLOAD : \*\*\*\*\*

Fully qualified filename of external SAP(R) Backint profile (.utl file) {PROFILE} = \*input mandatory\*

/oracle/OON/102\_64/dbs/initOON.utl

\*\*\*\*\* Profile parameters for section DEVICE\_CLASS STANDARD: \*\*\*\*\*

Type of Storage system {COPYSERVICES\_HARDWARE\_TYPE} (DS8000|SVC|XIV) = \*input mandatory\* DS8000  
 Server name/address of host running CIM Agent {COPYSERVICES\_PRIMARY\_SERVERNAME} =  
 [localhost] sapr3db2cl  
 Hostname of backup Copy Services server {COPYSERVICES\_SECONDARY\_SERVERNAME} = []  
 Username for storage device {COPYSERVICES\_USERNAME} = [superuser]  
 Communication protocol {COPYSERVICES\_COMMPROTOCOL} (HTTPS|HTTP) = [HTTPS]  
 Certificate file for HTTPS {COPYSERVICES\_CERTIFICATEFILE} (<filename>|NO\_CERTIFICATE) = [NO\_CERTIFICATE]  
 Copy Services server port number {COPYSERVICES\_SERVERPORT} = [5989]  
 Flashcopy type {FLASHCOPY\_TYPE} (INCR|COPY|NOCOPY) = [COPY]  
 Timeout for CIM Agent calls {COPYSERVICES\_TIMEOUT} (<minutes>) = [6]  
 Force restore {RESTORE\_FORCE} (YES|NO) = [NO]  
 Storage system ID of referred cluster {STORAGE\_SYSTEM\_ID} = [] IBM.2107-7581991  
 Target volumes set {TARGET\_SETS} (VOLUMES\_DIR|VOLUMES\_FILE) = \*input mandatory\*  
 VOLUMES\_FILE  
 Filename of the target volumes file {VOLUMES\_FILE} = \*input mandatory\* oon.oon.standard.node0000.fct

FMM8426I Saving profile '/oracle/OON/acs/profile' ...

FMM1555I Profile successfully created.

Please configure the TSM for ERP profile initOON.utl appropriately.

Do you want to continue by specifying passwords for the defined sections? [Y/N]

Y

Please enter the password for device section STANDARD: [\*\*\*]

→ Enter the DS8000 user's password here!

FMM8437I Verifying password...

FMM0005I Start of program at: Thu Sep 3 21:52:20 2009 .

FMM4184I CIM Agent version for DS8000: '5.2.0'.

FMM0020I End of program at: Thu Sep 3 21:52:21 2009 .

FMM0021I Elapsed time: 01 sec .

FMM6959I Script 'LIBPATH=/oracle/OON/acs/pegasus/oracle/OON/acs/fmcima -l /oracle/OON/acs -f checkpw' returned with code 0.

Creating password file at /oracle/OON/acs/shared/pwd.acsd.

A copy of this file needs to be available to all components that connect to acsd.

IBM Tivoli Storage FlashCopy(R) Manager requires at least two daemon processes to be running at all times.

The management daemon (acsd) and the generic device agent (acsngen) are typically registered in the /etc/inittab on the production server by the configuration wizard.

Both daemon processes restart after a system reboot.

If installing in a High Availability environment, both daemon processes must be started from the High Availability environment.

If you specify YES, these two daemon processes are not be added to the /etc/inittab and the required executable files and command-line options display.

Make sure these two daemon processes are started by the High Availability scripts. If you specify NO, /etc/inittab is used.

Do you want to install in a High Availability environment? [Y/N]

N

The off-loaded backup to Tivoli Storage Manager will be performed by the IBM Tivoli Storage FlashCopy(R) Manager offload agent 'tsm4acs'.

Specify YES to perform the off-loaded backup immediately after the FlashCopy backup completes. This adds 'tsm4acs' to the /etc/inittab.

The default is to run 'tsm4acs' as a daemon process on the production server.

In High Availability environments, no entry is made to /etc/inittab since 'tsm4acs' must be added to the High Availability script. Specify NO to schedule off-loaded backups individually with a crontab entry.

Do you want off-loaded tape backups to begin immediately after the snapshot? [Y/N]

Y

A backup system must be installed and configured when off-loaded backups to Tivoli Storage Manager are performed or when FlashCopy backup consistency verification is needed during a forced mount.

Note that remote connections from the production system to the backup system must already exist to use Open SSH.

Specify YES to use OpenSSH. When prompted to specify which DEVICE\_CLASS should be enabled on the backup system, either select from the list of available DEVICE\_CLASS parameters or press Enter to select all listed DEVICE\_CLASS parameters.

Specify NO if OpenSSH is not available, the INST\_DIR and ACS\_DIR use NFS to share between the production system and backup system,

or you want to configure the backup system in a separate step.

Do you want to install a new Backup System using the Open Secure Shell (OpenSSH) protocol? [Y/N]

Y

Please enter the hostname of the backup system:

sapr3oracl

sapr3oracl is reachable.

Enter the device classes to use for this Backup System. Make sure each device class is separated by a comma.

To use all defined device classes just hit enter.

The authenticity of host 'sapr3oracl (9.155.66.104)' can't be established.

RSA key fingerprint is 35:52:b0:ee:56:67:08:cb:d2:f3:a4:6b:f2:d0:35:f1.

Are you sure you want to continue connecting (yes/no)? yes

Warning: Permanently added 'sapr3oracl,9.155.66.104' (RSA) to the list of known hosts.

root@sapr3oracl's password:

start copying...

copy completed.

start agents

Successfully installed the Backup System.

Do you want to install a new Backup System using the Open Secure Shell (OpenSSH) protocol? [Y/N]

N

sapr3ora:oraon 5>