

IBM Cloud Object Storage System  
Version 3.14.1

*Slicestor 2212 Appliance Manual*  
*3409-S00/3401-S00/3403-S00*



**Note**

Before using this information and the product it supports, read the following information:

- The general information in *Notices*
- The information in *Safety and environmental notices*
- The information in the *IBM Environmental Notices and User Guide* (provided on a DVD)

This edition applies to IBM Cloud Object Storage System™ and is valid until replaced by new editions.

© Copyright IBM Corporation 2016, ..

US Government Users Restricted Rights – Use, duplication or disclosure restricted by GSA ADP Schedule Contract with IBM Corp.

---

# Contents

<b>Figures</b> . . . . .	<b>v</b>	Requirements . . . . .	5
<b>Tables</b> . . . . .	<b>vii</b>	System diagram . . . . .	6
<b>Document information</b> . . . . .	<b>ix</b>	<b>Chapter 4. Install the appliance into a rack</b> . . . . .	<b>7</b>
<b>Safety and environmental notices</b> . . . . .	<b>xi</b>	Prepare for installation . . . . .	7
Safety notices . . . . .	xi	Appliance installation . . . . .	9
Environmental notices . . . . .	xiv	<b>Chapter 5. Appliance physical interface</b> <b>15</b>	
Declared noise emissions . . . . .	xv	Front control panel . . . . .	15
<b>Support information</b> . . . . .	<b>xvii</b>	Rear panel. . . . .	16
<b>Chapter 1. Slicestor 2212 ApplianceManual</b> . . . . .	<b>1</b>	<b>Chapter 6. Field replaceable or upgrade units.</b> . . . . .	<b>19</b>
<b>Chapter 2. Appliance safety precautions</b> <b>3</b>		Replacement parts . . . . .	19
Physical . . . . .	3	Replace external front components . . . . .	19
Electrical. . . . .	3	Replace external rear components . . . . .	24
Electronic components . . . . .	4	Battery removal and installation . . . . .	25
<b>Chapter 3. Specifications and requirements</b> . . . . .	<b>5</b>	<b>Notices</b> . . . . .	<b>27</b>
Appliance specifications . . . . .	5	Trademarks . . . . .	29
		Homologation statement . . . . .	29



---

## Figures

1. System diagram . . . . .	6	17. If necessary, secure the appliance handles to front of rack with screws . . . . .	13
2. Drive layout . . . . .	6	18. Rear of appliance . . . . .	14
3. 2×M5×20 mm round head screws . . . . .	8	19. Front of appliance . . . . .	14
4. 8×M5×8 mm flat head screws . . . . .	8	20. Front panel buttons and LEDs for the appliance . . . . .	15
5. 4×M4×4 mm flat head screws . . . . .	8	21. Rear panel I/O ports for the appliance . . . . .	16
6. 8×Cone washers for M5 . . . . .	9	22. LAN LED connection speed indicator . . . . .	17
7. 2×C13-to-C14 connector, 6 ft, 14 AWG power cables . . . . .	9	23. Extending the handle for a drive from the chassis . . . . .	20
8. 2×Rack rails . . . . .	9	24. Removing a drive from the chassis . . . . .	21
9. Identifying rail parts . . . . .	9	25. Extending the handle for a drive from the chassis . . . . .	22
10. Extend and release inner rail . . . . .	10	26. Removing a drive from the chassis . . . . .	23
11. Installing the inner rails . . . . .	11	27. Removing a PSU from the chassis . . . . .	25
12. Inner rails installed on appliance . . . . .	11	28. Remove the battery . . . . .	26
13. Extending and releasing the outer rails . . . . .	11	29. Install the battery . . . . .	26
14. Securing the outer rail to the rack with screws . . . . .	12		
15. Extending the outer rail to reach the rear posts of the rack . . . . .	12		
16. Ball-bearing shuttle in the middle rail . . . . .	13		



---

## Tables

1. Declared noise emissions in accordance with ISO 9296 <sup>(1,2,3)</sup> . . . . .	xv
2. System components in the appliance . . . . .	5
3. Space and power requirements for the appliance. . . . .	5
4. Operating and non-operating temperatures and humidity for the appliance. . . . .	5
5. Cabling requirements for the appliance. . . . .	5
6. Appliance location considerations . . . . .	7
7. Legend for rear panel I/O Ports for the appliance . . . . .	16
8. LAN LED connection speed colors. . . . .	17
9. Power supply LED states . . . . .	17
10. Conditions indicated by drive carrier LEDs . . . . .	17
11. Descriptions for the ports represented by this appliance . . . . .	18





---

## Document information

### Intended purpose and audience

This manual contains the instructions for installing and maintaining this appliance. The audience for this guide consists of those individuals responsible for installing IBM Cloud Object Storage System™ appliances.

#### Note:

- The equipment and device described for installation herein are sophisticated and relatively complex to install. The party or parties installing the equipment must be familiar with installations of computer hardware and disk drives prior to attempting this installation. Only personnel proficient in working with computer hardware and disk drives should attempt to install this appliance.
- After all appliances have been installed in the rack, refer to the *Appliance Configuration Guide* to configure the appliance settings required prior to setting up the system.
- After these appliances are configured, refer to the *System Manager Administration Guide* for information about how to configure, operate, and maintain your system.
- Both the *Appliance Configuration Guide* and the *System Manager Administration Guide* assume that all necessary appliances for the system are installed in the rack.



---

## Safety and environmental notices

Review the safety notices, environmental notices, and electronic emission notices for IBM® Cloud Object Storage System before you install and use the product.

Suitability for telecommunication environment - This product is not intended to connect directly or indirectly by any means whatsoever to interfaces of public telecommunications networks.

Examples of a caution and a danger notice. Numbers in parentheses refer to message numbers in the *IBM Safety Notices* publication G229-9054, which is included with your product.

### **CAUTION:**

**A caution notice indicates the presence of a hazard that has the potential of causing moderate or minor personal injury. (C001)**

### **DANGER**

<b>A danger notice indicates the presence of a hazard that has the potential of causing death or serious personal injury. (D002)</b>
--

---

## Safety notices

Safety notices for this product.

Familiarize yourself with the *IBM Safety Notices* publication G229-9054, which is included with your product.

**DANGER:** When working on or around the system, observe the following precautions:

Electrical voltage and current from power, telephone, and communication cables are hazardous. To avoid a shock hazard:

- If IBM supplied a power cord(s), connect power to this unit only with the IBM provided power cord. Do not use the IBM provided power cord for any other product.
- Do not open or service any power supply assembly.
- Do not connect or disconnect any cables or perform installation, maintenance, or reconfiguration of this product during an electrical storm.
- The product might be equipped with multiple power cords. To remove all hazardous voltages, disconnect all power cords.
- Connect all power cords to a properly wired and grounded electrical outlet. Ensure that the outlet supplies proper voltage and phase rotation according to the system rating plate.
- Connect any equipment that will be attached to this product to properly wired outlets.
- When possible, use one hand only to connect or disconnect signal cables.
- Never turn on any equipment when there is evidence of fire, water, or structural damage.
- Do not attempt to switch on power to the machine until all possible unsafe conditions are corrected.
- Assume that an electrical safety hazard is present. Perform all continuity, grounding, and power checks specified during the subsystem installation procedures to ensure that the machine meets safety requirements.
- Do not continue with the inspection if any unsafe conditions are present.
- Disconnect the attached power cords, telecommunications systems, networks, and modems before you open the device covers, unless instructed otherwise in the installation and configuration procedures.
- Connect and disconnect cables as described in the following procedures when installing, moving, or opening covers on this product or attached devices.

To disconnect:

1. Turn off everything (unless instructed otherwise).
2. Remove the power cords from the outlets.
3. Remove the signal cables from the connectors.
4. Remove all cables from the devices.

To connect:

1. Turn off everything (unless instructed otherwise).
  2. Attach all cables to the devices.
  3. Attach the signal cables to the connectors.
  4. Attach the power cords to the outlets.
  5. Turn on the devices.
- Sharp edges, corners and joints may be present in and around the system. Use care when handling equipment to avoid cuts, scrapes and pinching. (D005)

**DANGER:** Heavy equipment — personal injury or equipment damage might result if mishandled. (D006)

**DANGER:** Professional movers are to be used for all relocation activities. Serious injury or death may occur if systems are handled and moved incorrectly. (D008)

**DANGER:** Serious injury or death can occur if loaded lift tool falls over or if a heavy load falls off the lift tool. Always completely lower the lift tool load plate and properly secure the load on the lift tool before moving or using the lift tool to lift or move an object. (D010)

**CAUTION:** The battery contains lithium. To avoid possible explosion, do not burn or charge the battery.

**Do not:** Throw or immerse into water, heat to more than 100°C (212°F), repair or disassemble. (C003)

Use the following general safety information for all rack mounted devices:

**DANGER:** Observe the following precautions when working on or around your IT rack system:

- Heavy equipment—personal injury or equipment damage might result if mishandled.
- Always lower the leveling pads on the rack cabinet.
- Always install stabilizer brackets on the rack cabinet.
- To avoid hazardous conditions due to uneven mechanical loading, always install the heaviest devices in the bottom of the rack cabinet. Always install servers and optional devices starting from the bottom of the rack cabinet.
- Rack-mounted devices are not to be used as shelves or work spaces. Do not place objects on top of rack-mounted devices.



- Each rack cabinet might have more than one power cord. Be sure to disconnect all power cords in the rack cabinet when directed to disconnect power during servicing.
- Connect all devices installed in a rack cabinet to power devices installed in the same rack cabinet. Do not plug a power cord from a device installed in one rack cabinet into a power device installed in a different rack cabinet.
- An electrical outlet that is not correctly wired could place hazardous voltage on the metal parts of the system or the devices that attach to the system. It is the responsibility of the customer to ensure that the outlet is correctly wired and grounded to prevent an electrical shock. (R001 part 1 of 2)

**CAUTION:**

- Do not install a unit in a rack where the internal rack ambient temperatures will exceed the manufacturer's recommended ambient temperature for all your rack-mounted devices.
- Do not install a unit in a rack where the air flow is compromised. Ensure that air flow is not blocked or reduced on any side, front or back of a unit used for air flow through the unit.
- Consideration should be given to the connection of the equipment to the supply circuit so that overloading of the circuits does not compromise the supply wiring or overcurrent protection. To provide the correct power connection to a rack, refer to the rating labels located on the equipment in the rack to determine the total power requirement of the supply circuit.
- (For sliding drawers): Do not pull out or install any drawer or feature if the rack stabilizer brackets are not attached to the rack. Do not pull out more than one drawer at a time. The rack might become unstable if you pull out more than one drawer at a time.
- (For fixed drawers): This drawer is a fixed drawer and must not be moved for servicing unless specified by the manufacturer. Attempting to move the drawer partially or completely out of the rack might cause the rack to become unstable or cause the drawer to fall out of the rack.  
(R001 part 2 of 2)

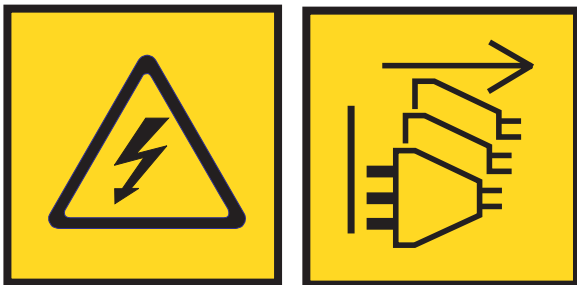

**DANGER:** Multiple power cords. The product might be equipped with multiple power cords. To remove all hazardous voltages, disconnect all power cords. (L003)

**CAUTION:**

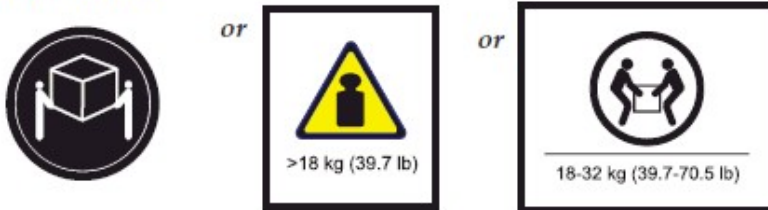

The weight of this part or unit is between 18 and 32 kg (39.7 and 70.5 lb). It takes two persons to safely lift this part or unit. (C009)

---

## Environmental notices

This information contains all of the environmental notices for IBM Systems products in English and other languages.

The IBM Systems Environmental Notices information includes statements on limitations, product information, product recycling and disposal, battery information, flat panel display, refrigeration and water-cooling systems, external power supplies, and safety data sheets.

## Declared noise emissions

Table 1. Declared noise emissions in accordance with ISO 9296<sup>(1,2,3)</sup>

Product description	Declared A-Weighted Sound Power Level, $L_{WAAd}$ (B)		Declared A-Weighted Sound Pressure Level, $L_{pAm}$ (dB)	
	Operating	Idling	Operating	Idling
Model S00 @ 25 deg. C room ambient	5.6	5.4	39	37
Model S00 @ 35 deg. C room ambient	7.7 <sup>(4)</sup>	7.7 <sup>(4)</sup>	61	61
Model S00 @ 25 deg. C room ambient Acoustical Doors Feature codes FC EC07 = back FC EC08 = front	5.2	5.0	34	32
Model S00 @ 35 deg. C room ambient Acoustical Doors Feature codes FC EC07 = back FC EC08 = front	7.0	7.0	55	55

Notes:

1. Declared level  $L_{WAAd}$  is the upper-limit A-weighted sound power level; Declared level  $L_{pAm}$  is the mean A-weighted sound pressure level measured at the 1-meter bystander positions.
2. All measurements made in conformance with ISO 7779 and declared in conformance with ISO 9296.
3. B, dB, abbreviations for bels and decibels, respectively. 1 B = 10 dB.
4. **Note:** Government regulations (such as those prescribed by OSHA or European Community Directives) may govern noise level exposure in the workplace and may apply to you and your server installation. This IBM system is available with an optional acoustical door feature that can help reduce the noise emitted from this system. The actual sound pressure levels in your installation depend upon a variety of factors, including the number of racks in the installation; the size, materials, and configuration of the room where you designate the racks to be installed; the noise levels from other equipment; the room ambient temperature, and employees' location in relation to the equipment. Further, compliance with such government regulations also depends upon a variety of additional factors, including the duration of employees' exposure and whether employees wear hearing protection. IBM recommends that you consult with qualified experts in this field to determine whether you are in compliance with the applicable regulations.





---

## Support information

For more information on the product or help with troubleshooting, contact IBM Support at [IBMCloudStorageSupport@us.ibm.com](mailto:IBMCloudStorageSupport@us.ibm.com) or visit the Directory of worldwide contacts.



---

# Chapter 1. Slicestor<sup>®</sup> 2212 ApplianceManual

This manual contains the instructions for installing and maintaining the Slicestor<sup>®</sup> 2212A appliance.



---

## Chapter 2. Appliance safety precautions

Observe physical, electrical, and electronic component safety precautions.

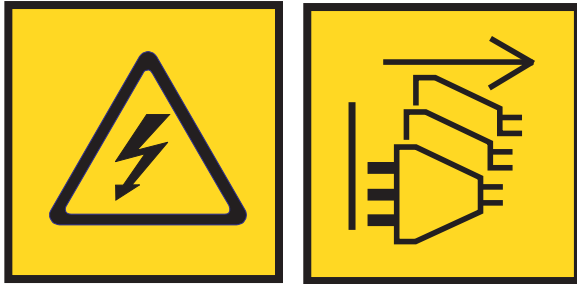

**DANGER:** An electrical outlet that is not correctly wired could place hazardous voltage on the metal parts of the system or the devices that attach to the system. It is the responsibility of the customer to ensure that the outlet is correctly wired and grounded to prevent an electrical shock. (D004)

**DANGER:** Multiple power cords. The product might be equipped with multiple power cords. To remove all hazardous voltages, disconnect all power cords. (L003)

---

### Physical

Ensure that your equipment rack is placed in a dust-free, well-ventilated area close to an uninterruptible power supply (UPS). Leave enough room behind and around the rack for services and sufficient airflow.

- Keep the area around the appliance clean and free of clutter.
- Place the appliance top cover and any appliance components that were removed away from the appliance or on a table so that they do not accidentally get damaged.
- While you are working on the appliance, do not wear loose clothing such as neckties and unbuttoned shirt sleeves. They can retain a charge even if you are wearing a wrist strap, or could be pulled into a fan.
- After you access the inside of the appliance, close the appliance and secure it to the rack unit with the retention screws after you ensure that all connections are made.
- Close the rack's front door and all panels and components on the appliances when not servicing to maintain proper cooling.

---

### Electrical

Basic electrical safety precautions must be followed to protect yourself and the appliance:

- Do not work alone with high-voltage components.
- Be aware of the locations of the power switch on the appliance and the room's emergency power-off switch, disconnection switch, or electrical outlet. If an electrical accident occurs, quickly remove power from the system.

## DANGER

A danger of explosion exists if the Onboard battery is installed upside down, which reverses its polarities. This battery must be replaced only with the same or an equivalent type that is recommended by the manufacturer. Dispose of used batteries according to the battery manufacturer's instructions.

---

## Electronic components

Electrostatic discharge (ESD) is generated by two objects with different electrical charges when they come into contact with each other. An ESD neutralizes this difference, which can damage electronic components and printed circuit boards (PCBs). In general, the following measures are sufficient to neutralize this difference before contact is made to protect equipment from ESD:

- Use a grounded wrist strap that is designed to prevent ESDs.
- Keep all components in their antistatic containers until ready for installation.
- Touch a grounded metal object before you remove any board from its antistatic container.
- Remove any jewelry or metal objects from your body. They are excellent metal conductors that can create short circuits and harm you if they come into contact with printed circuit boards or areas where power is present.

---

## Chapter 3. Specifications and requirements

See the appendix for additional specifications.

---

### Appliance specifications

- All RAM is PC3-12800 DDR3 ECC SDRAM.
- All NICs are on board.

Table 2. System components in the appliance

CPU	SDRAM (GB)	OS drive (TB)	Data drives	PSUs	NIC ports (1 Gbps)	NIC ports (10 Gbps)
Intel Xeon E5-2620	4x8	1x0.5	12	2	2	0

**Note:** Extra Networking Options

The appliance can support another networking card to provide either 2x1 Gbps or 2x10 Gbps Ethernet ports. These ports are found in the leftmost card slot on the rear of the appliance.

---

### Requirements

#### Physical space and power

The appliance uses 100 - 240 VAC, and the frequency is 50 - 60 Hz.

Table 3. Space and power requirements for the appliance

Model	Rack Units	W (in)	H (in)	D (in)	Weight (lbs)	W (cm)	H (cm)	D (cm)	Weight (kg)	Power (W)
S2212	2	17.2	3.50	25.5	52.0	43.7	8.9	64.8	23.6	290

#### Environmental conditions

Table 4. Operating and non-operating temperatures and humidity for the appliance

Environment	Temperature (°C)	Temperature (°F)	Humidity (non-condensing)
Operating	10–35	50–95	8–90%
Non-operating	-40–70	-40–158	5–95%

#### Cabling

Table 5. Cabling requirements for the appliance

Cable	Type and Usage
Power Cords	Use only the power cords that are supplied with the appliance. Do not use another type of cord. Do not use extension cords. If extra power cords are needed, contact IBM Support.
1000BASE-T Copper Cables	Use high-quality Category 5e or 5 (CAT5e, CAT5) copper cables.

## System diagram

The following figures show the appliance schematics.

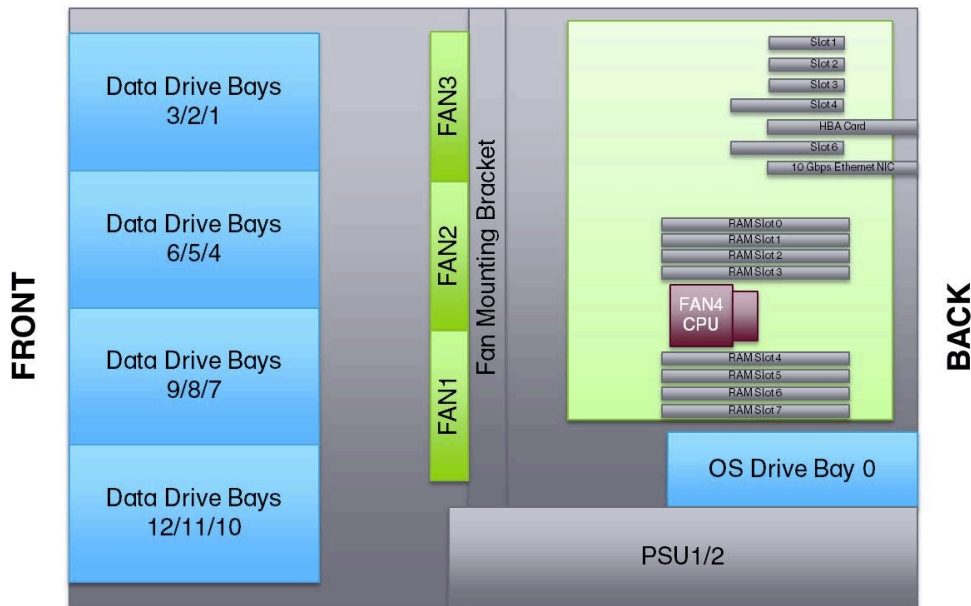

Figure 1. System diagram

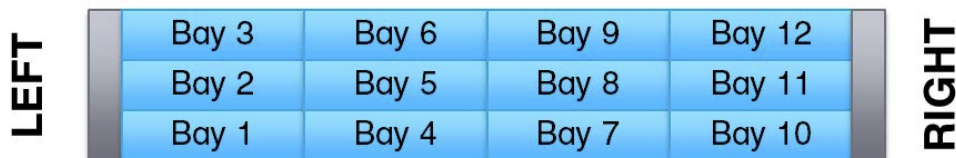

Figure 2. Drive layout



---

## Chapter 4. Install the appliance into a rack

Many racks are on the market, which means that the assembly procedure might differ slightly. This rail fits a rack between 27.0" and 36.0" deep.

---

### Prepare for installation

#### Assemble tools

A #2 Phillips screwdriver and a cage nut tool are needed to install and secure the rails to the appliance.

Wear a set of leather work gloves when racking the appliance. They help to get a grip on the appliance and avoid injury from any metal edges.

#### CAUTION:

**Do not use of any sort of hammer to secure the rails on the appliance. A hammer might damage the drives within the chassis and possibly void the warranty.**

#### Choose a setup location

Decide on a suitable location for the rack unit that holds your appliance.

*Table 6. Appliance location considerations*

Factor	Comments
Restricted access location	Install this appliance in a physically secure, limited access location only, such as a service closet or data center.
Clean environment	Situate it in a clean, well-ventilated, dust-free area.
Ambient operating temperature	If installed in a closed or multi-unit rack assembly, the ambient operating temperature of the rack environment might be greater than the ambient temperature of the room. Install the equipment in an environment compatible with the maximum rated ambient temperature (TMRA) for the appliance.
Sufficient airflow	Mount the equipment into a rack so that the amount of airflow that is needed for safe operation is not compromised. Leave enough clearance in front of the rack to open the front door completely (36 inches). Leave about 36 inches of clearance behind the rack for sufficient airflow and ease in servicing.
Mechanical loading	Mount the equipment into a rack so that a hazardous condition does not arise due to uneven mechanical loading. Install heavier items into the bottom of the equipment rack to keep the rack stable. Mount equipment in a rack evenly to prevent a later hazard.
Circuit overloading	Give consideration to the connection of the equipment to the power supply circuitry and the effect that any possible overloading of circuits might have on overcurrent protection and power supply wiring. Appropriate consideration of equipment nameplate ratings should be used when addressing this concern. <b>Note:</b> The maximum current draw is printed on a label on the appliance power supplies. The system might draw more than 15 Amps at startup (inrush current).
Reliable ground	A reliable ground must be maintained always. To ensure grounding, the rack itself should be grounded. Particular attention should be given to power supply connections other than the direct connections to the branch circuit, such as the use of power strips.

Table 6. Appliance location considerations (continued)

Factor	Comments
Power supply	Use a regulating uninterruptible power supply (UPS) to protect the appliance from power surges and voltage spikes, and to keep your system operating in a power failure.
Heat, electricity, and EMI	Avoid areas where heat, electrical noise, and electromagnetic fields are generated.

## Prepare the rack

1. Ensure that the leveling jacks on the bottom of the rack are fully extended to the floor with the full weight of the rack resting on them.
  - In single rack installations, attach stabilizers to the rack.
  - In multiple rack installations, couple the racks together.
2. Check that the rack is stable before extending an appliance from the rack.
3. Extend only one appliance at a time. Extending two or more simultaneously can destabilize the rack.
4. Determine the placement of each appliance in the rack before you install the rails.
5. Install the heaviest appliances (usually the Slicestor<sup>®</sup> appliances) on the bottom of the rack first, and then work upward.

## Box contents

Inspect the box for any damage. In addition to the appliance, the box includes the hardware in the following figures:



Figure 3. 2xM5x20 mm round head screws



Figure 4. 8xM5x8 mm flat head screws



Figure 5. 4xM4x4 mm flat head screws



Figure 6. 8×Cone washers for M5



Figure 7. 2×C13-to-C14 connector, 6 ft, 14 AWG power cables

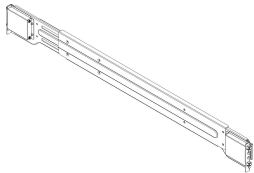

Figure 8. 2×Rack rails

---

## Appliance installation

**Attention:** Allow the enclosure assembly to acclimate to room temperature before installation. Disk drives should be stored at room temperature for at least 2 hours before use.

### Identify the sections of the rack rails

The appliance package has two rail assemblies in the mounting kit with three sections, as shown in the following figure:

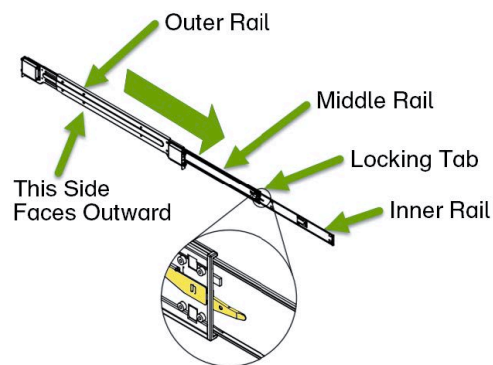

Figure 9. Identifying rail parts

- An inner appliance rail that secures directly to the appliance.
- Each inner rail has a locking tab.

- This tab locks the appliance into place when installed and pushed fully into the rack.
- These tabs also lock the appliance in place when fully extended from the rack.
- This system prevents the appliance from coming out of the rack when the appliance is pulled out for servicing.
- An outer rail that secures to the rack.
- A middle rail that extends from the outer rail.

These assemblies are designed for the left and right side of the appliance.

### Release the inner rail from the outer rails

1. Identify the left and right outer rail assemblies.
2. Pull the inner rail out of the outer rail until it is fully extended as in the following figure:

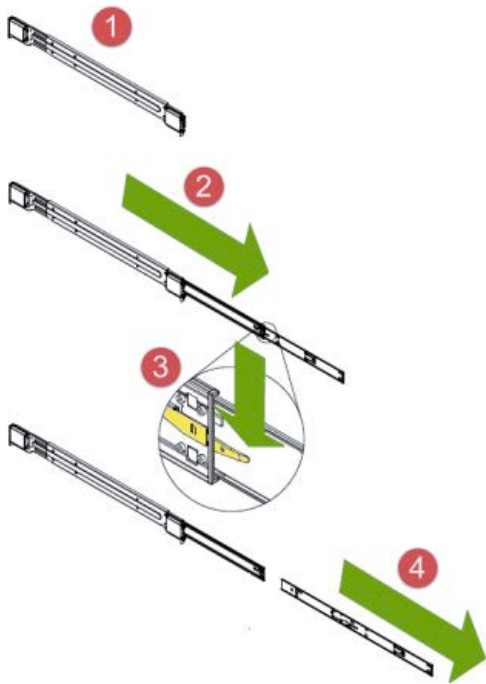

Figure 10. Extend and release inner rail

3. Press the locking tab down to release the inner rail.
4. Pull out the inner rail.
5. Repeat these steps for the opposite outer rail.

### Install the inner rails on the appliance

1. Confirm that the left and right inner rails are correctly identified.
2. Place the inner rail firmly against the side of the appliance, aligning the hooks on the side of the appliance with the holes in the inner rail.

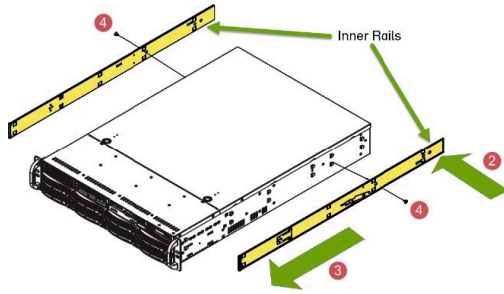

Figure 11. Installing the inner rails

- Slide the inner rail forward toward the front of the appliance until the rail clicks into the locked position, which secures the inner rail to the appliance.

**Important:** Make sure all of the hooks are pushed through the holes in the rail and are not between the rail and the appliance. Such a misalignment interferes with putting the appliance in the rack.

- Secure the inner rail to the appliance with the screws provided.
- Repeat these steps for the opposite inner rail.
- The appliance is now ready to install into the rack, as shown in the following figure:

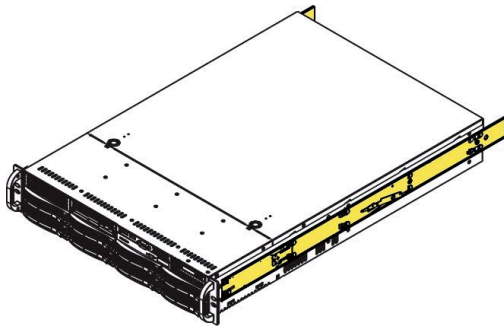

Figure 12. Inner rails installed on appliance

### Install the outer rails on the rack

- Press upward on the locking tab at the rear end of the middle rail, as shown in the following figure:

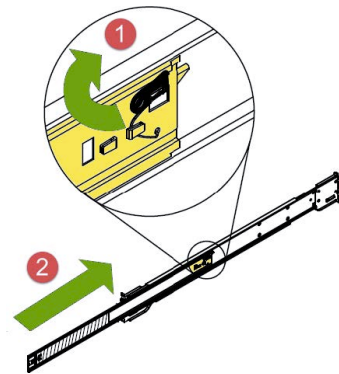

Figure 13. Extending and releasing the outer rails

- Push the middle rail back into the outer rail.

3. Hang the hooks of the front of the outer rail onto the slots on the front of the rack. If necessary, use screws to secure the outer rails to the rack, as shown in the following figure.

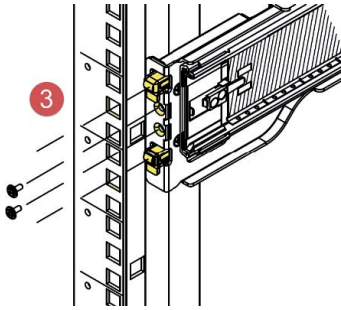

Figure 14. Securing the outer rail to the rack with screws

4. Pull out the rear of the outer rail, adjusting the length until it fits within the posts of the rack, as shown in the following figure.

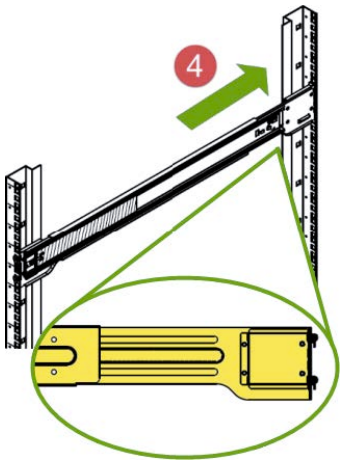

Figure 15. Extending the outer rail to reach the rear posts of the rack

5. Hang the hooks of the rear portion of the outer rail onto the slots on the rear of the rack. If necessary, use screws to secure the rear of the outer rail to the rear of the rack.
6. Repeat these steps for the remaining outer rail.

### Install the appliance into a rack

1. Confirm that the inner rails are properly installed on the appliance.
2. Confirm that the outer rails are correctly installed on the rack.
3. Pull the middle rail out from the front of the outer rail and make sure that the ball-bearing shuttle is at the front locking position of the middle rail.

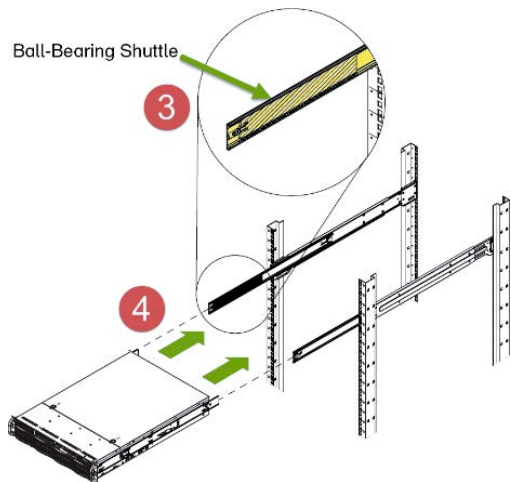

Figure 16. Ball-bearing shuttle in the middle rail

4. Align the appliance inner rails with the front of the middle rails.
5. Slide the inner rails on the appliance into the middle rails. Keep the pressure even on both sides until the locking tab of the inner rail clicks into the front of the middle rail. It locks the appliance into the fully extended position.
6. Depress the locking tabs of both sides simultaneously and push the appliance completely into the rear of the rack.
7. If necessary, use screws to secure the appliance handles to the front of the rack, as shown in the following figure.

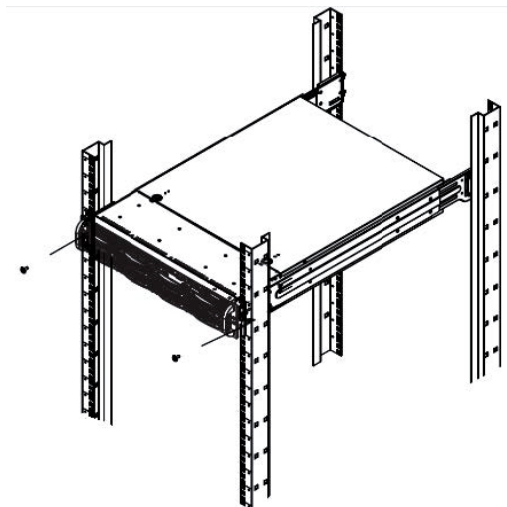

Figure 17. If necessary, secure the appliance handles to front of rack with screws

### Cable the appliance

1. On the rear panel, connect the power cables. The power connections are at the left of the appliance, as shown in the following figure.

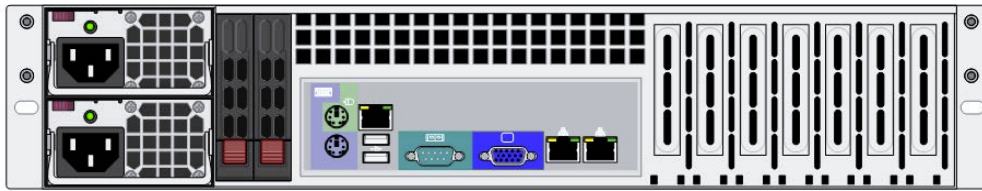

Figure 18. Rear of appliance

2. The Ethernet connections are located just to the right of the center of the appliance and are next to each other. They are labeled ETH0 on the left and ETH1 on the right. Connect a standard Ethernet cable to the left Ethernet port.
3. Press the power button that is on the lower left corner of the appliance front panel.
4. To ensure that the power is on, verify that the power and network link lights are lit and listen for running fans, as shown in the following figure.

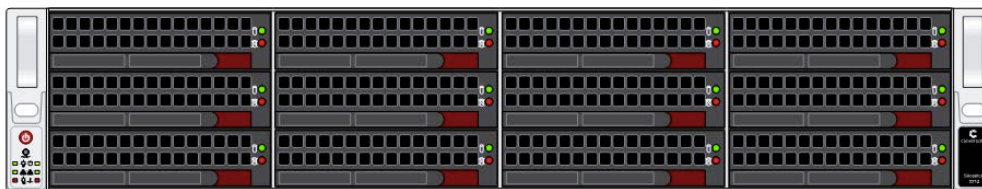

Figure 19. Front of appliance



---

## Chapter 5. Appliance physical interface

The physical interface for the appliance consists of buttons and LEDs on the front panel and ports and LEDs on the back panel.

---

### Front control panel

The power status and the hard disk drive and network activity of the appliance can be read from its front control panel, as shown in the following figure.

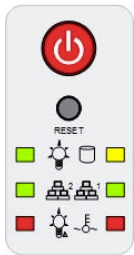

Figure 20. Front panel buttons and LEDs for the appliance

### Physical buttons

The appliance includes two push buttons on the right of the front panel:



Reboots the system.



Applies or removes power from the power supply to the appliance. Powering down the appliance removes the main power, but supplies stand-by power. The appliance must be unplugged before servicing.

### LEDs

The control panel has five LEDs to provide critical information for different components:



Power supplied to PSUs - lit when the appliance is operating.



Hard disk activity.



Network activity on ETH0 when it is flashing.



Network activity on ETH1 when it is flashing.



Power supply failure when it is flashing.



Fan failure when it is flashing. Overheat condition when it is lit. Check the following conditions:

- Room temperature
- Cable routing inside appliance
- All fans are present and operating normally.
- Appliance covers are installed.
- Heat sinks are installed properly.

## Rear panel

The rear panel contains I/O ports, network interface ports, power supplies, and a hard disk carrier.

### I/O ports

The I/O ports are color-coded per the PC 99 specification. The locations of the various I/O ports are shown in the following figure.

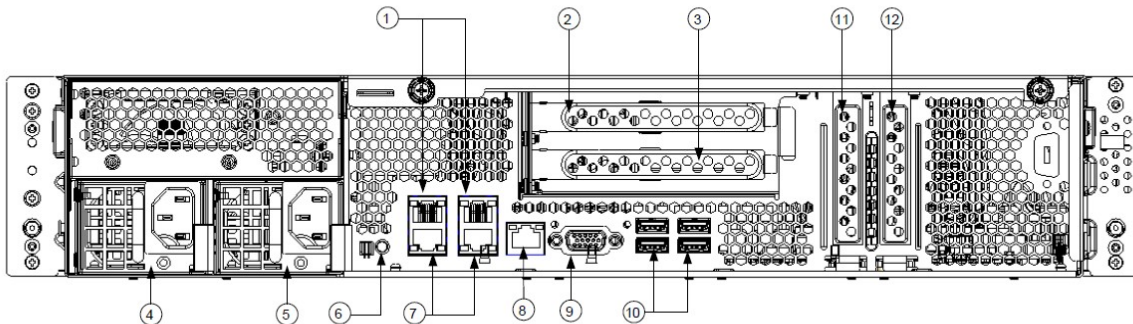

Figure 21. Rear panel I/O ports for the appliance

Table 7. Legend for rear panel I/O Ports for the appliance

1	1 GbE RJ45 ports (2)	7	1 GbE RJ45 ports (2)
2	PCIe card slot (on riser card)	8	10/100 Mbit/s management port
3	PCIe card slot (on riser card)	9	DB-15 video connector
4	Power supply 1	10	USB 2.0 ports (4)
5	Power supply 2	11	Disk controller card slot (for LSI 9260-8i or LSI 9211-8i)

Table 7. Legend for rear panel I/O Ports for the appliance (continued)

6	Unit identification button/LED	12	Unpopulated PCIe slot
---	--------------------------------	----	-----------------------

## Network interface ports

The LAN ports have two LEDs. One LED indicates activity when it is flashing. The other LED can be green, amber or off to indicate the speed of the connection, as shown in the following figure. See the following table for the functions that are associated with the connection speed LED.



Figure 22. LAN LED connection speed indicator

Table 8. LAN LED connection speed colors

Color	Speed
Off	No connection or 10 Mbps
Green	100 Mbps
Amber	1 Gbps

## Intelligent Platform Management Interface (IPMI)

This network port allows remote administration of hardware. For a detailed description of IPMI, refer to the following Intel documentation.

<https://www.intel.com/content/www/us/en/servers/ipmi/ipmi-home.html>

## Power supplies

Each power supply includes one LED with three states in the rear.

Table 9. Power supply LED states

Solid green	Solid amber	Flashing amber
System on	System off and plugged in.	Internal temperature reached 63°C.
On	Plugged in and turned off or the appliance is off but in an abnormal state.	Appliance automatically powers down when PSU temperature reaches 70°C and restarts when the PSU temperature drops below 60°C.

## Hard disk carrier

Each drive carrier has one LED with two states.

Table 10. Conditions indicated by drive carrier LEDs

Condition	LED color
Drive activity	Green
Drive failure	Red

## Ports

The following ports are on this model of Accesser®.

*Table 11. Descriptions for the ports represented by this appliance*

<b>Port</b>	<b>Description</b>
VGA (DB-15)	The DB-15 video connector can connect a monitor to this port by using a VGA cable. The maximum video resolution is 1600 x 1200 at 75 Hz.
USB 2.0	The USB ports can connect a USB keyboard or the supplied USB memory key to any of these connectors.

---

## Chapter 6. Field replaceable or upgrade units

A number of components can be replaced or upgraded in the field.

---

### Replacement parts

Contact IBM Support for replacement parts for the appliance.

The following customer serviceable parts are available:

- Power supply module
- Operating system drive
- Data drives

The following customer serviceable upgrade units are available:

- Optical modules (SFP+/QSFP)

See the *Field Replaceable Units Reference Guide* for a complete list of available drives.

---

### Replace external front components

#### Replace a data drive

1. Press the release button on the drive carrier. This action extends the carrier handle, as shown in the following figure.

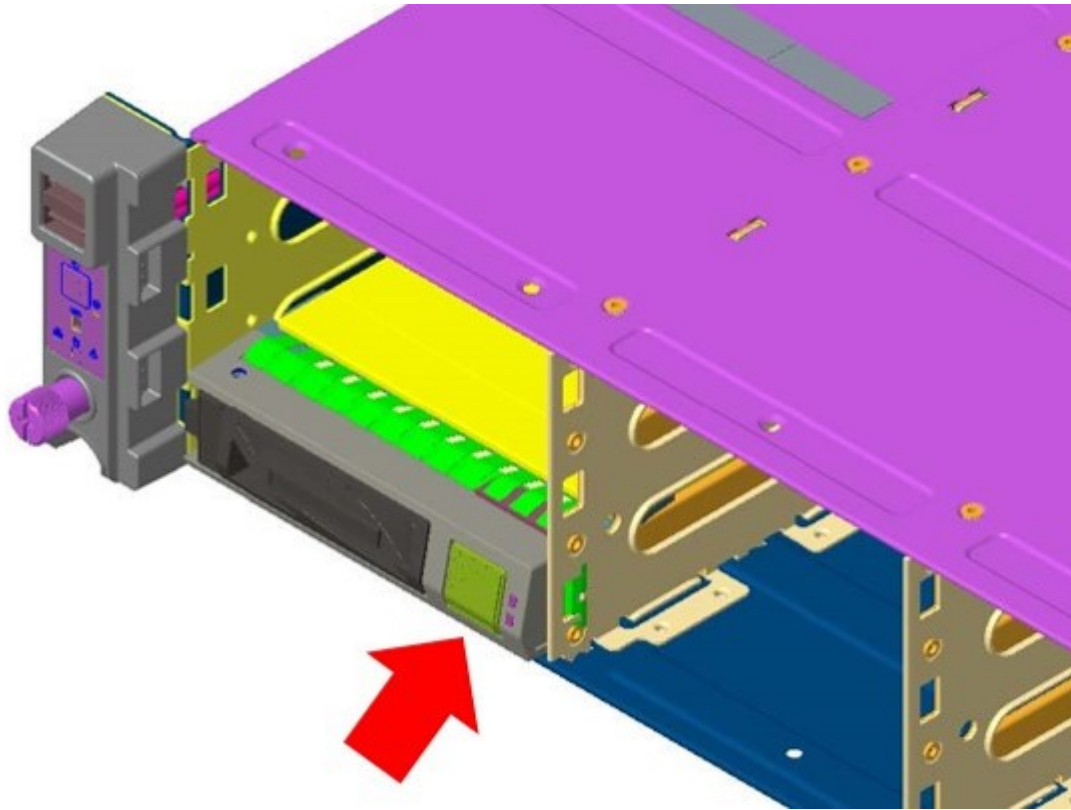

*Figure 23. Extending the handle for a drive from the chassis*

2. Pull the drive carrier out of the chassis by using the handle.

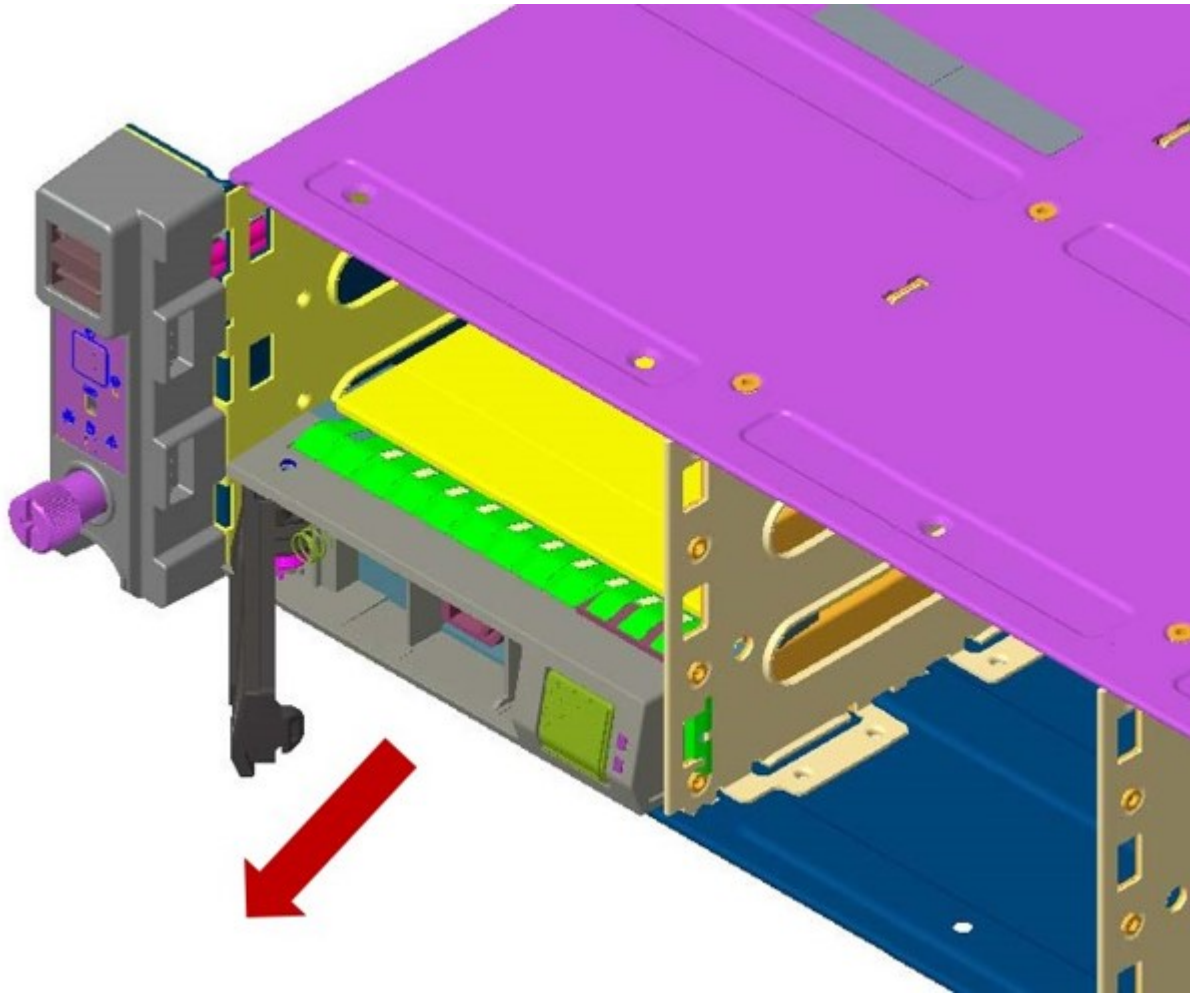

*Figure 24. Removing a drive from the chassis*

3. Insert the new data drive into the open slot in the front of the appliance.
4. Close the drive carrier by using the drive carrier handle.

### **Replace an operating system drive**

1. Log in to the device as local admin.
2. At the command prompt, type `poweroff`.
3. After the appliance is powered off, remove the power cord and network cables from the back of the chassis.
4. Press the release button on the drive carrier. This action extends the carrier handle, as shown in the following figure.

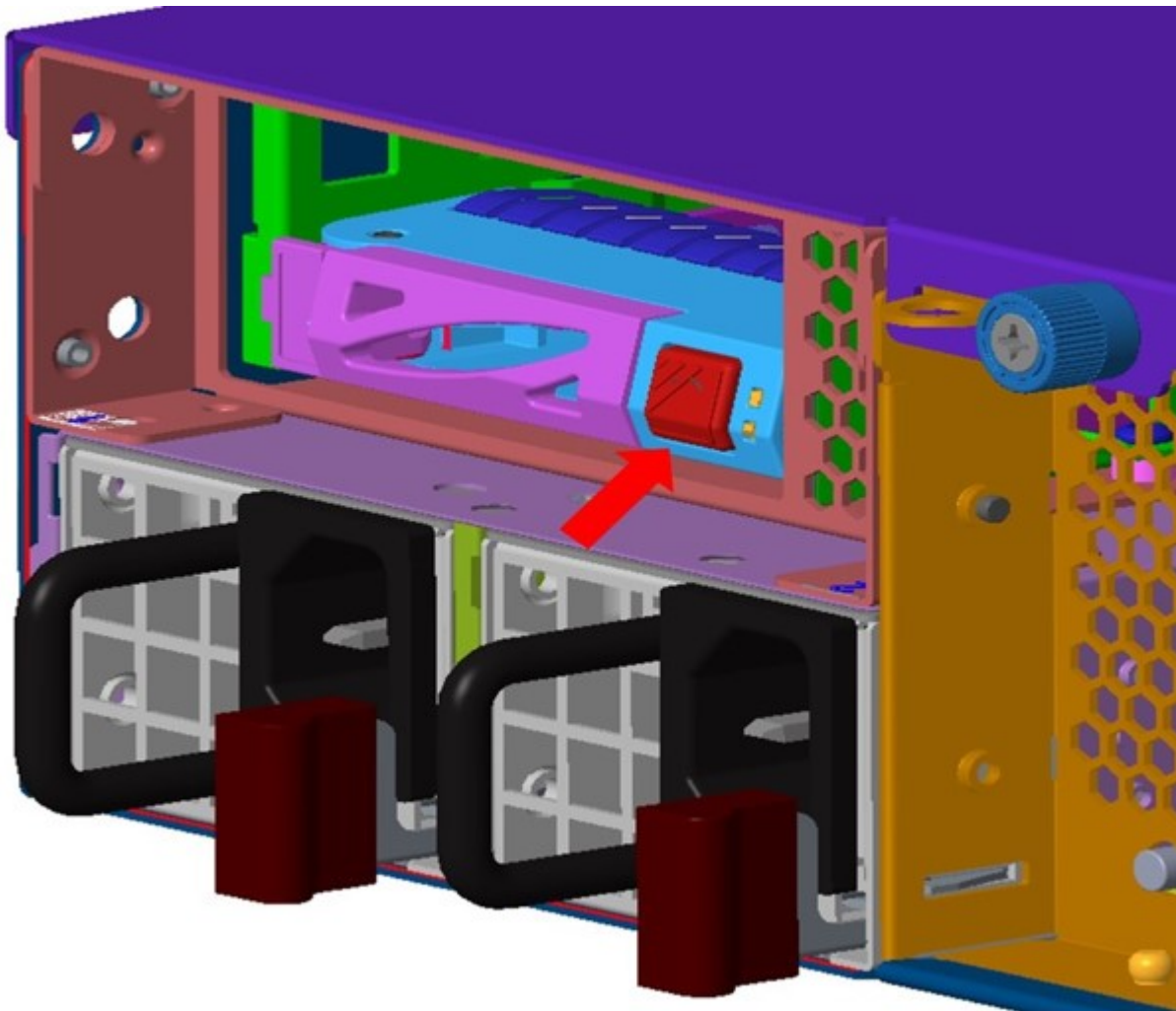
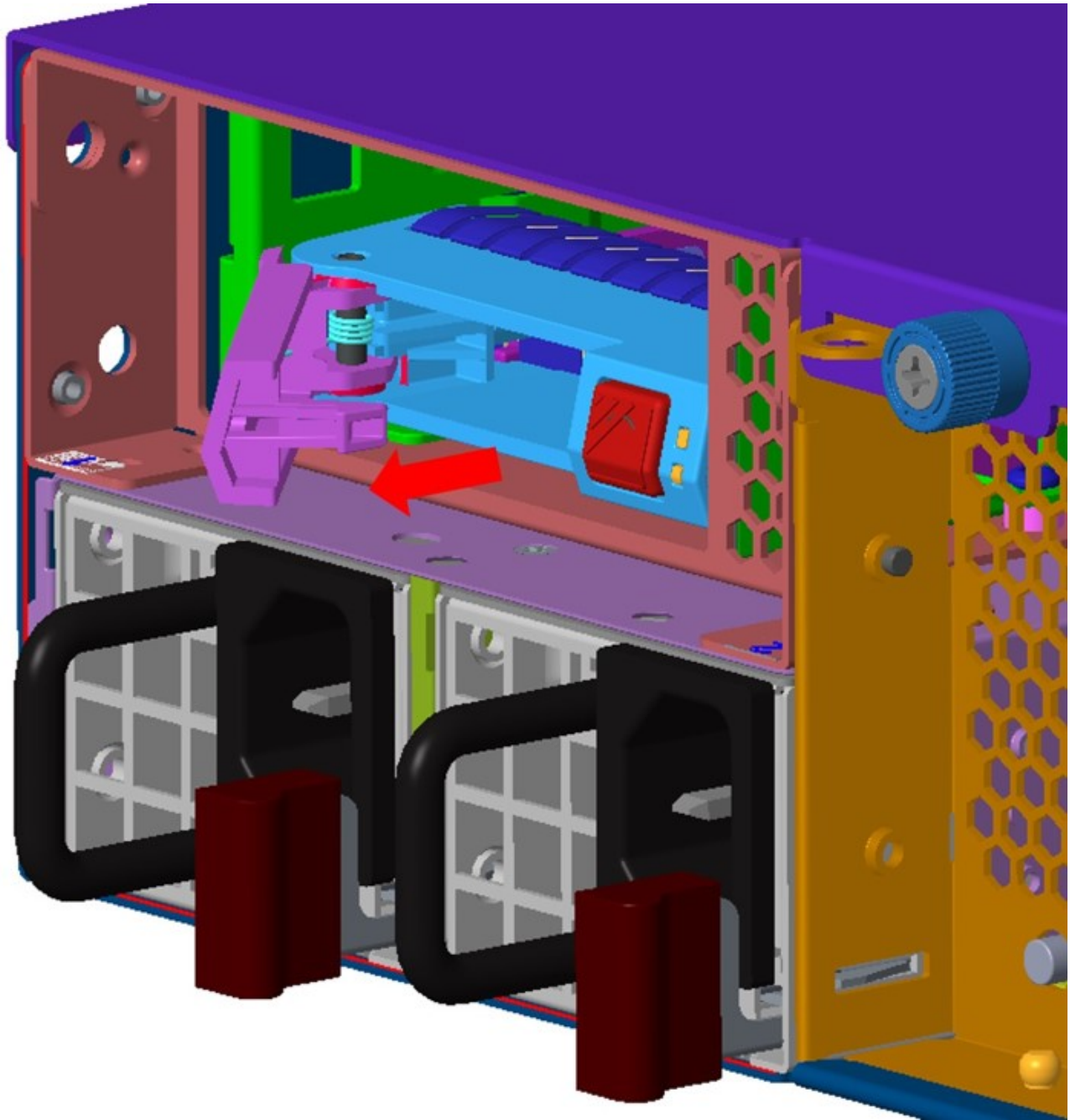

Figure 25. Extending the handle for a drive from the chassis

5. Pull the drive carrier out of the chassis by using the handle.





*Figure 26. Removing a drive from the chassis*

6. Insert the new OS drive into the open slot in the front of the appliance.
7. Close the drive carrier by using the drive carrier handle.
8. Plug in the power cable and network cables.
9. Power on the appliance.

### **Install an operating system on a drive**

**Note:** To install an operating system (OS) on a drive, you need a USB flash drive, a computer running a Linux OS, a VGA-capable monitor, and a USB keyboard.

**CAUTION:**

The following procedure destroys any existing data on the USB flash drive.

1. Download the installation ISOs from IBM.
2. Insert the USB flash drive into the computer.
3. Determine the name of this drive.  
`#lsblk`
4. Determine that the drive is not mounted.  
`#mount`
5. Copy the ClevOS ISO to the USB flash drive.  
`#dd if={path}/{ClevOS}.iso of=/dev/{drivename} bs=1M`
6. When copying is done, remove the USB flash drive from the computer.
7. Power down the device on which you want to install the OS.
  - If the device is in an unresponsive state, it can be powered down by PDU or by removing the power cables.
  - If the device is still responding, do the following steps.
    - a. Log in to the device as `localadmin`.
    - b. At the command prompt, type `poweroff/`
8. Attach the USB keyboard and VGA monitor to the device.
9. Insert the USB flash drive in the remaining USB port.
10. Restart the machine while pressing **F11** to enter the boot menu.
11. In the boot menu, select **USB Key** and press **Enter**. The device loads the operating system, and the installer appears.
12. In the installer, choose **OS only install**. When installation completes, the device reboots.
13. After the device reboots, remove the USB flash drive.

---

## Replace external rear components

### Replace a power supply unit

If either of the two power supply units (PSU) fails, the other unit takes the full load and the system can continue operation without interruption. The **power supply** icon on the control panel flashes until the failed unit is replaced.

The power supply modules have a hot-swap capability; you can replace the failed module without powering down the system. The redundant feature keeps the appliance online while the failed hot-swap module is replaced.

1. Push the release tab on the rear of the PSU, as shown in the following figure.

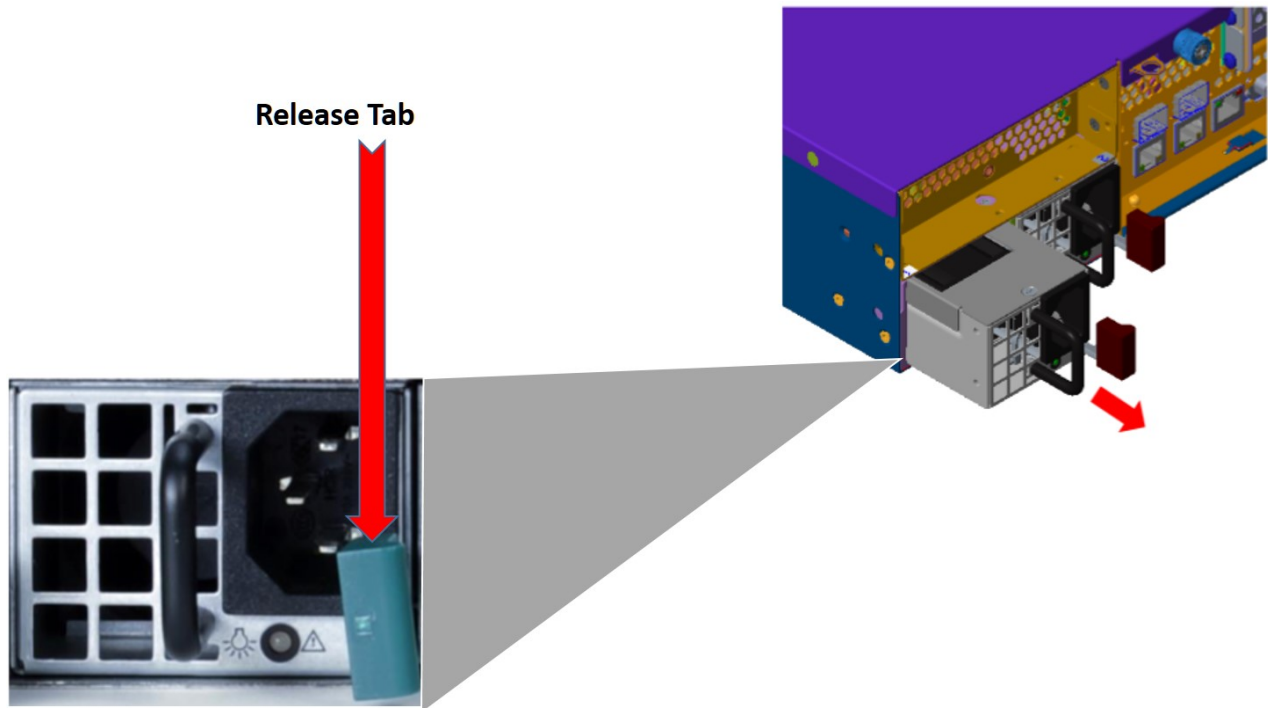

Figure 27. Removing a PSU from the chassis

2. Pull the PSU out using the provided handle. (The PSU wiring is designed to detach automatically when the PSU is pulled from the chassis).
3. Replace the failed PSU with another PSU.
4. Push the new PSU into the power bay until you hear a click.

### Install an SFP+ / QSFP optical module

1. Log in to the device as local admin.
2. At the command prompt, type poweroff.
3. Remove the SFP+ / QSFP module from the packaging.
4. Remove the black plastic protective cap from the optical side of the module.
5. Insert the module into the network card until it clicks into place.
6. Insert the fiber optic cable into the SFP+ / QSFP module.
7. Restart system and configure the network interface. For more information, see the *Appliance Configuration Guide*.

---

## Battery removal and installation

### Battery removal

**CAUTION:** The battery contains lithium. To avoid possible explosion, do not burn or charge the battery.

**Do not:** Throw or immerse into water, heat to more than 100°C (212°F), repair or disassemble. (C003)

To remove the Onboard battery, follow these steps:

1. Power off your system and unplug your power cable.

2. Locate the Onboard battery, as shown in the figure.
3. Using a tool such as a pen or a small screwdriver, push the battery lock outwards to unlock it. When unlocked, the battery pops out from the holder.
4. Remove the battery, as shown in the following figure.

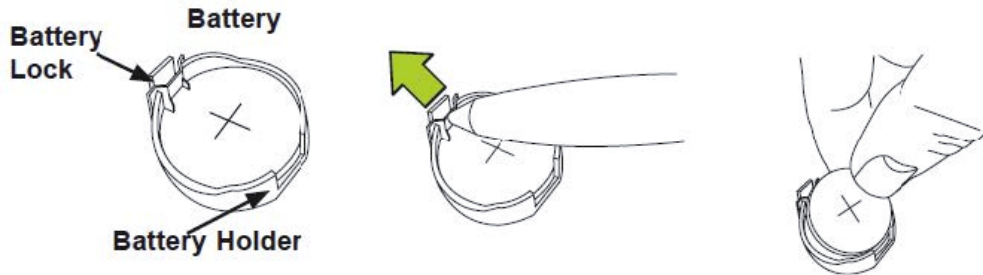

Figure 28. Remove the battery

**CAUTION:**

Handle used batteries carefully. Do not damage the battery in any way; a damaged battery can release hazardous materials into the environment. Do not discard a used battery in the garbage or a public landfill. Refer to the IBM Systems Environmental Notices for battery disposal guidelines.

**Battery installation**

To install an onboard battery, follow these steps:

1. Identify the battery's polarity. The positive (+) side must be facing up.
2. Insert the battery into the battery holder. Push it down until you hear a click to ensure that the battery is securely locked, as shown in the following figure.



Figure 29. Install the battery

**CAUTION:**

Be sure to replace the battery with the same type only.

---

## Notices

This information was developed for products and services offered in the US. This material might be available from IBM in other languages. However, you may be required to own a copy of the product or product version in that language in order to access it.

IBM may not offer the products, services, or features discussed in this document in other countries. Consult your local IBM representative for information on the products and services currently available in your area. Any reference to an IBM product, program, or service is not intended to state or imply that only that IBM product, program, or service may be used. Any functionally equivalent product, program, or service that does not infringe any IBM intellectual property right may be used instead. However, it is the user's responsibility to evaluate and verify the operation of any non-IBM product, program, or service.

IBM may have patents or pending patent applications covering subject matter described in this document. The furnishing of this document does not grant you any license to these patents. You can send license inquiries, in writing, to:

*IBM Director of Licensing  
IBM Corporation  
North Castle Drive  
Armonk, NY 10504-1785  
U.S.A.*

For license inquiries regarding double-byte character set (DBCS) information, contact the IBM Intellectual Property Department in your country or send inquiries, in writing, to:

*Intellectual Property Licensing  
Legal and Intellectual Property Law  
IBM Japan, Ltd.  
19-21, Nihonbashi-Hakozakicho, Chuo-ku  
Tokyo 103-8510, Japan*

INTERNATIONAL BUSINESS MACHINES CORPORATION PROVIDES THIS PUBLICATION "AS IS" WITHOUT WARRANTY OF ANY KIND, EITHER EXPRESS OR IMPLIED, INCLUDING, BUT NOT LIMITED TO, THE IMPLIED WARRANTIES OF NON-INFRINGEMENT, MERCHANTABILITY OR FITNESS FOR A PARTICULAR PURPOSE. Some jurisdictions do not allow disclaimer of express or implied warranties in certain transactions, therefore, this statement may not apply to you.

This information could include technical inaccuracies or typographical errors. Changes are periodically made to the information herein; these changes will be incorporated in new editions of the publication. IBM may make improvements and/or changes in the product(s) and/or the program(s) described in this publication at any time without notice.

Any references in this information to non-IBM websites are provided for convenience only and do not in any manner serve as an endorsement of those websites. The materials at those websites are not part of the materials for this IBM product and use of those websites is at your own risk.

IBM may use or distribute any of the information you provide in any way it believes appropriate without incurring any obligation to you.

Licensees of this program who wish to have information about it for the purpose of enabling: (i) the exchange of information between independently created programs and other programs (including this one) and (ii) the mutual use of the information which has been exchanged, should contact:

*IBM Director of Licensing  
IBM Corporation  
North Castle Drive, MD-NC119  
Armonk, NY 10504-1785  
US*

Such information may be available, subject to appropriate terms and conditions, including in some cases, payment of a fee.

The licensed program described in this document and all licensed material available for it are provided by IBM under terms of the IBM Customer Agreement, IBM International Program License Agreement or any equivalent agreement between us.

The performance data discussed herein is presented as derived under specific operating conditions. Actual results may vary.

Information concerning non-IBM products was obtained from the suppliers of those products, their published announcements or other publicly available sources. IBM has not tested those products and cannot confirm the accuracy of performance, compatibility or any other claims related to non-IBM products. Questions on the capabilities of non-IBM products should be addressed to the suppliers of those products.

Statements regarding IBM's future direction or intent are subject to change or withdrawal without notice, and represent goals and objectives only.

All IBM prices shown are IBM's suggested retail prices, are current and are subject to change without notice. Dealer prices may vary.

This information is for planning purposes only. The information herein is subject to change before the products described become available.

This information contains examples of data and reports used in daily business operations. To illustrate them as completely as possible, the examples include the names of individuals, companies, brands, and products. All of these names are fictitious and any similarity to the names and addresses used by an actual business enterprise is entirely coincidental.

#### COPYRIGHT LICENSE:

This information contains sample application programs in source language, which illustrate programming techniques on various operating platforms. You may copy, modify, and distribute these sample programs in any form without payment to IBM, for the purposes of developing, using, marketing or distributing application programs conforming to the application programming interface for the operating platform for which the sample programs are written. These examples have not been thoroughly tested under all conditions. IBM, therefore, cannot guarantee or imply reliability, serviceability, or function of these programs. The sample programs are provided "AS IS", without warranty of any kind. IBM shall not be liable for any damages arising out of your use of the sample programs.

If you are viewing this information softcopy, the photographs and color illustrations may not appear.

---

## Trademarks

IBM, the IBM logo, and [ibm.com](http://ibm.com)<sup>®</sup> are trademarks or registered trademarks of International Business Machines Corp., registered in many jurisdictions worldwide. Other product and service names might be trademarks of IBM or other companies. A current list of IBM trademarks is available on the web at Copyright and trademark information at [www.ibm.com/legal/copytrade.shtml](http://www.ibm.com/legal/copytrade.shtml).

Accesser<sup>®</sup>, Cleversafe<sup>®</sup>, ClevOS<sup>™</sup>, Dispersed Storage<sup>®</sup>, dsNet<sup>®</sup>, IBM Cloud Object Storage Accesser<sup>®</sup>, IBM Cloud Object Storage Dedicated<sup>™</sup>, IBM Cloud Object Storage Insight<sup>™</sup>, IBM Cloud Object Storage Manager<sup>™</sup>, IBM Cloud Object Storage Slicestor<sup>®</sup>, IBM Cloud Object Storage Standard<sup>™</sup>, IBM Cloud Object Storage System<sup>™</sup>, IBM Cloud Object Storage Vault<sup>™</sup>, SecureSlice<sup>™</sup>, and Slicestor<sup>®</sup> are trademarks or registered trademarks of Cleversafe, an IBM Company and/or International Business Machines Corp.

Other product and service names might be trademarks of IBM or other companies.

---

## Homologation statement

This product may not be certified in your country for connection by any means whatsoever to interfaces of public telecommunications networks. Further certification may be required by law prior to making any such connection. Contact an IBM representative or reseller for any questions.









Printed in USA