

IBM Cloud Object Storage System  
Version 3.14.1

*Accesser F5100 Appliance Manual*  
*3401-A02/3403-A02*



**Note**

Before using this information and the product it supports, read the following information:

- The general information in *Notices*
- The information in *Safety and environmental notices*
- The information in the *IBM Environmental Notices and User Guide* (provided on a DVD)

This edition applies to IBM Cloud Object Storage System Accesser F5100 and is valid until replaced by new editions.

© Copyright IBM Corporation 2016, ..

US Government Users Restricted Rights – Use, duplication or disclosure restricted by GSA ADP Schedule Contract with IBM Corp.

---

# Contents

**Figures . . . . . v**

**Tables . . . . . vii**

**Safety and environmental notices . . . . ix**

Safety notices . . . . . ix

Environmental notices. . . . . xii

    Declared noise emissions . . . . . xiii

**Support information . . . . . xv**

**Chapter 1. Appliance safety precautions 1**

Physical . . . . . 1

Electrical. . . . . 1

Electronic components . . . . . 2

**Chapter 2. Specifications and requirements . . . . . 3**

Appliance specifications . . . . . 3

Requirements . . . . . 3

**Chapter 3. Install the appliance into a rack . . . . . 5**

Prepare for installation . . . . . 5

Appliance installation . . . . . 7

**Chapter 4. Appliance physical interface 13**

Front control panel . . . . . 13

Rear panel. . . . . 14

Network interface ports . . . . . 15

**Chapter 5. Field replaceable units . . . 17**

Replacement parts . . . . . 17

Replace external front components . . . . . 17

Replace external rear components . . . . . 18

Battery removal and installation . . . . . 19

**Notices . . . . . 21**

Trademarks . . . . . 23

Homologation statement . . . . . 23



---

## Figures

1. Rear of the appliance with the card slot highlighted . . . . .	3	11. Rear of appliance . . . . .	11
2. Identifying the sections of the rack rails . . . . .	7	12. Front of appliance . . . . .	11
3. Remove the inner rails from both rail kits . . . . .	7	13. Front panel buttons and LEDs for the appliance . . . . .	13
4. Retracting the outer rail . . . . .	8	14. Rear panel I/O ports for the appliance . . . . .	14
5. Attaching the sections of the rack inner rails . . . . .	8	15. LAN LED connection speed indicator . . . . .	15
6. Aligning the outer rails with holes in rack post . . . . .	9	16. Removing a drive from the chassis . . . . .	18
7. Push outer rail into rack post . . . . .	9	17. Removing a PSU from the chassis . . . . .	18
8. Attach back of outer rail . . . . .	9	18. Remove the battery . . . . .	19
9. Final outer rail assembly and mounting . . . . .	10	19. Install the battery . . . . .	20
10. Push chassis into rack . . . . .	11		



---

## Tables

1. Declared noise emissions in accordance with ISO 9296 <sup>(1,2,3)</sup> . . . . .	xiii	5. Legend for rear panel I/O Ports for the appliance . . . . .	15
2. Cabling requirements for the appliance. . . . .	3	6. LAN LED connection speed colors. . . . .	15
3. Appliance location considerations . . . . .	5	7. Power supply LED states . . . . .	15
4. Legend for front panel buttons and LEDs . . . . .	13	8. Conditions indicated by drive carrier LEDs . . . . .	16





---

## Safety and environmental notices

Review the safety notices, environmental notices, and electronic emission notices for IBM® Cloud Object Storage System before you install and use the product.

Suitability for telecommunication environment - This product is not intended to connect directly or indirectly by any means whatsoever to interfaces of public telecommunications networks.

Examples of a caution and a danger notice. Numbers in parentheses refer to message numbers in the *IBM Safety Notices* publication G229-9054, which is included with your product.

### **CAUTION:**

**A caution notice indicates the presence of a hazard that has the potential of causing moderate or minor personal injury. (C001)**

### **DANGER**

<b>A danger notice indicates the presence of a hazard that has the potential of causing death or serious personal injury. (D002)</b>
--

---

## Safety notices

Safety notices for this product.

Familiarize yourself with the *IBM Safety Notices* publication G229-9054, which is included with your product.

**DANGER:** When working on or around the system, observe the following precautions:

Electrical voltage and current from power, telephone, and communication cables are hazardous. To avoid a shock hazard:

- If IBM supplied a power cord(s), connect power to this unit only with the IBM provided power cord. Do not use the IBM provided power cord for any other product.
- Do not open or service any power supply assembly.
- Do not connect or disconnect any cables or perform installation, maintenance, or reconfiguration of this product during an electrical storm.
- The product might be equipped with multiple power cords. To remove all hazardous voltages, disconnect all power cords.
- Connect all power cords to a properly wired and grounded electrical outlet. Ensure that the outlet supplies proper voltage and phase rotation according to the system rating plate.
- Connect any equipment that will be attached to this product to properly wired outlets.
- When possible, use one hand only to connect or disconnect signal cables.
- Never turn on any equipment when there is evidence of fire, water, or structural damage.
- Do not attempt to switch on power to the machine until all possible unsafe conditions are corrected.
- Assume that an electrical safety hazard is present. Perform all continuity, grounding, and power checks specified during the subsystem installation procedures to ensure that the machine meets safety requirements.
- Do not continue with the inspection if any unsafe conditions are present.
- Disconnect the attached power cords, telecommunications systems, networks, and modems before you open the device covers, unless instructed otherwise in the installation and configuration procedures.
- Connect and disconnect cables as described in the following procedures when installing, moving, or opening covers on this product or attached devices.

To disconnect:

1. Turn off everything (unless instructed otherwise).
2. Remove the power cords from the outlets.
3. Remove the signal cables from the connectors.
4. Remove all cables from the devices.

To connect:

1. Turn off everything (unless instructed otherwise).
  2. Attach all cables to the devices.
  3. Attach the signal cables to the connectors.
  4. Attach the power cords to the outlets.
  5. Turn on the devices.
- Sharp edges, corners and joints may be present in and around the system. Use care when handling equipment to avoid cuts, scrapes and pinching. (D005)

**DANGER:** Heavy equipment — personal injury or equipment damage might result if mishandled. (D006)

**DANGER:** Professional movers are to be used for all relocation activities. Serious injury or death may occur if systems are handled and moved incorrectly. (D008)

**DANGER:** Serious injury or death can occur if loaded lift tool falls over or if a heavy load falls off the lift tool. Always completely lower the lift tool load plate and properly secure the load on the lift tool before moving or using the lift tool to lift or move an object. (D010)

**CAUTION:** The battery contains lithium. To avoid possible explosion, do not burn or charge the battery.

**Do not:** Throw or immerse into water, heat to more than 100°C (212°F), repair or disassemble. (C003)

Use the following general safety information for all rack mounted devices:

**DANGER:** Observe the following precautions when working on or around your IT rack system:

- Heavy equipment—personal injury or equipment damage might result if mishandled.
- Always lower the leveling pads on the rack cabinet.
- Always install stabilizer brackets on the rack cabinet.
- To avoid hazardous conditions due to uneven mechanical loading, always install the heaviest devices in the bottom of the rack cabinet. Always install servers and optional devices starting from the bottom of the rack cabinet.
- Rack-mounted devices are not to be used as shelves or work spaces. Do not place objects on top of rack-mounted devices.



- Each rack cabinet might have more than one power cord. Be sure to disconnect all power cords in the rack cabinet when directed to disconnect power during servicing.
- Connect all devices installed in a rack cabinet to power devices installed in the same rack cabinet. Do not plug a power cord from a device installed in one rack cabinet into a power device installed in a different rack cabinet.
- An electrical outlet that is not correctly wired could place hazardous voltage on the metal parts of the system or the devices that attach to the system. It is the responsibility of the customer to ensure that the outlet is correctly wired and grounded to prevent an electrical shock.  
(R001 part 1 of 2)

**CAUTION:**

- Do not install a unit in a rack where the internal rack ambient temperatures will exceed the manufacturer's recommended ambient temperature for all your rack-mounted devices.
- Do not install a unit in a rack where the air flow is compromised. Ensure that air flow is not blocked or reduced on any side, front or back of a unit used for air flow through the unit.
- Consideration should be given to the connection of the equipment to the supply circuit so that overloading of the circuits does not compromise the supply wiring or overcurrent protection. To provide the correct power connection to a rack, refer to the rating labels located on the equipment in the rack to determine the total power requirement of the supply circuit.
- (For sliding drawers): Do not pull out or install any drawer or feature if the rack stabilizer brackets are not attached to the rack. Do not pull out more than one drawer at a time. The rack might become unstable if you pull out more than one drawer at a time.
- (For fixed drawers): This drawer is a fixed drawer and must not be moved for servicing unless specified by the manufacturer. Attempting to move the drawer partially or completely out of the rack might cause the rack to become unstable or cause the drawer to fall out of the rack.  
(R001 part 2 of 2)

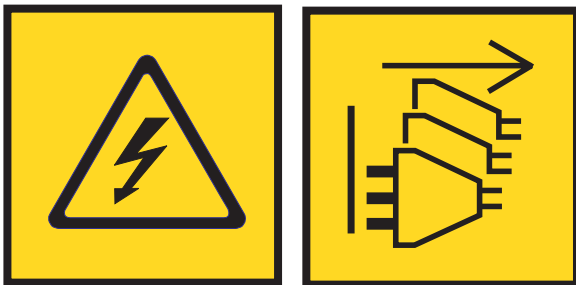

**DANGER:** Multiple power cords. The product might be equipped with multiple power cords. To remove all hazardous voltages, disconnect all power cords. (L003)

**CAUTION:**



The weight of this part or unit is between 18 and 32 kg (39.7 and 70.5 lb). It takes two persons to safely lift this part or unit. (C009)

---

## Environmental notices

This information contains all of the environmental notices for IBM Systems products in English and other languages.

The IBM Systems Environmental Notices information includes statements on limitations, product information, product recycling and disposal, battery information, flat panel display, refrigeration and water-cooling systems, external power supplies, and safety data sheets.

## Declared noise emissions

### Declared noise emissions in accordance with ISO 9296<sup>(1, 2, 3)</sup>

Table 1. Declared noise emissions in accordance with ISO 9296<sup>(1,2,3)</sup>

Product description	Declared A-Weighted Sound Power Level, $L_{WAAd}$ (B)		Declared A-Weighted Sound Pressure Level, $L_{pAm}$ (dB)	
	Operating	Idling	Operating	Idling
Models: A00, A01, A02, M01 @ 25 deg. C room ambient	7.2 <sup>(4)</sup>	6.8	56	52
Models: A00, A01, A02, M01 @ 35 deg. C room ambient	7.2 <sup>(4)</sup>	7.2 <sup>(4)</sup>	56	56
Models: A00, A01, A02, M01 @ 25 deg. C room ambient Acoustical Doors Feature codes FC EC07 = back FC EC08 = front	6.6	6.2	49	45
Models: A00, A01, A02, M01 @ 35 deg. C room ambient Acoustical Doors Feature codes FC EC07 = back FC EC08 = front	6.6	6.6	49	49
Notes:				
1. Declared level $L_{WAAd}$ is the upper-limit A-weighted sound power level; Declared level $L_{pAm}$ is the mean A-weighted sound pressure level measured at the 1-meter bystander positions.				
2. All measurements made in conformance with ISO 7779 and declared in conformance with ISO 9296.				
3. B, dB, abbreviations for bels and decibels, respectively. 1 B = 10 dB.				
4. <b>Note:</b> Government regulations (such as those prescribed by OSHA or European Community Directives) may govern noise level exposure in the workplace and may apply to you and your server installation. This IBM system is available with an optional acoustical door feature that can help reduce the noise emitted from this system. The actual sound pressure levels in your installation depend upon a variety of factors, including the number of racks in the installation; the size, materials, and configuration of the room where you designate the racks to be installed; the noise levels from other equipment; the room ambient temperature, and employees' location in relation to the equipment. Further, compliance with such government regulations also depends upon a variety of additional factors, including the duration of employees' exposure and whether employees wear hearing protection. IBM recommends that you consult with qualified experts in this field to determine whether you are in compliance with the applicable regulations.				



---

## Support information

For more information on the product or help with troubleshooting, contact IBM Support at [IBMCloudStorageSupport@us.ibm.com](mailto:IBMCloudStorageSupport@us.ibm.com) or visit the Directory of worldwide contacts.





---

## Chapter 1. Appliance safety precautions

Observe physical, electrical, and electronic component safety precautions.

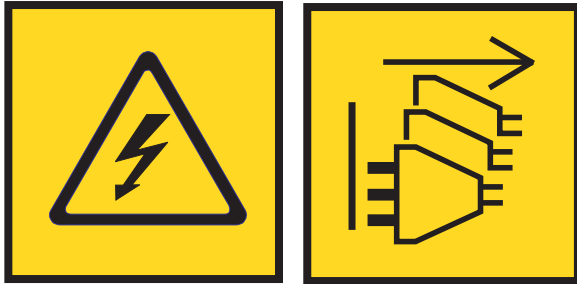

**DANGER:** An electrical outlet that is not correctly wired could place hazardous voltage on the metal parts of the system or the devices that attach to the system. It is the responsibility of the customer to ensure that the outlet is correctly wired and grounded to prevent an electrical shock. (D004)

**DANGER:** Multiple power cords. The product might be equipped with multiple power cords. To remove all hazardous voltages, disconnect all power cords. (L003)

---

### Physical

Ensure that your equipment rack is placed in a dust-free, well-ventilated area close to an uninterruptible power supply (UPS). Leave enough room behind and around the rack for services and sufficient airflow.

- Keep the area around the appliance clean and free of clutter.
- Place the appliance top cover and any appliance components that were removed away from the appliance or on a table so that they do not accidentally get damaged.
- While you are working on the appliance, do not wear loose clothing such as neckties and unbuttoned shirt sleeves. They can retain a charge even if you are wearing a wrist strap, or could be pulled into a fan.
- After you access the inside of the appliance, close the appliance and secure it to the rack unit with the retention screws after you ensure that all connections are made.
- Close the rack's front door and all panels and components on the appliances when not servicing to maintain proper cooling.

---

### Electrical

Basic electrical safety precautions must be followed to protect yourself and the appliance:

- Do not work alone with high-voltage components.
- Be aware of the locations of the power switch on the appliance and the room's emergency power-off switch, disconnection switch, or electrical outlet. If an electrical accident occurs, quickly remove power from the system.

## DANGER

A danger of explosion exists if the Onboard battery is installed upside down, which reverses its polarities. This battery must be replaced only with the same or an equivalent type that is recommended by the manufacturer. Dispose of used batteries according to the battery manufacturer's instructions.

---

## Electronic components

Electrostatic discharge (ESD) is generated by two objects with different electrical charges when they come into contact with each other. An ESD neutralizes this difference, which can damage electronic components and printed circuit boards (PCBs). In general, the following measures are sufficient to neutralize this difference before contact is made to protect equipment from ESD:

- Use a grounded wrist strap that is designed to prevent ESDs.
- Keep all components in their antistatic containers until ready for installation.
- Touch a grounded metal object before you remove any board from its antistatic container.
- Remove any jewelry or metal objects from your body. They are excellent metal conductors that can create short circuits and harm you if they come into contact with printed circuit boards or areas where power is present.

---

## Chapter 2. Specifications and requirements

See the appendix for additional specifications.

---

### Appliance specifications

- 2 x Intel Xeon E5-2683v3 processors
- 16 x 16 GB PC4-17000 2133 MHz ECC Registered RAM modules
- 1U server with 8 front-accessible 2.5" drive bays
- Six 4-cm internal fans
- 2 hot-swappable 750 W PSUs in 1+1 configuration
- 8 OS drives - High Endurance SSD
- Onboard IPMI
- 2 Onboard 1 Gbps network ports.
- 1 Onboard 1 Gbps dedicated IPMI network port.

**Note:** Extra Networking Option

The appliance can support another networking card to provide extra Ethernet ports. This port is found to the right of center on the rear of the appliance, as shown in the following figure.



Figure 1. Rear of the appliance with the card slot highlighted

---

## Requirements

### Cabling

Table 2. Cabling requirements for the appliance

Cable	Type and Usage
Power Cords	Use only the power cords that are supplied with the appliance. Do not use another type of cord. Do not use extension cords. If more power cords are needed, contact IBM Support.
1000BASE-T Copper Cables	Use high-quality Category 5e or 5 (CAT5e, CAT5) copper cables.
Optical Fiber Cables	Use Intel based enhanced small form-factor pluggable (SFP+) transceivers only. Both short reach (SFP+ SR) and long reach (SFP+ LR) optics are supported. Optical fiber cable specifications depend on the SFP+ module used. For more detail, refer to <i>Intel documentation on Modules and Cables</i> .
Direct Attach Copper Cables	Any SFP+ passive or active direct attach copper cable compliant with the SFF-8431 v4.1 and SFF-8472 v10.4 specifications is supported. For more information, see <i>Intel documentation on Modules and Cables</i> .



---

## Chapter 3. Install the appliance into a rack

Many different racks are on the market, which means that the assembly procedure might differ slightly. This rail fits a rack between 26.5" and 34.5" deep.

---

### Prepare for installation

#### Assemble tools

A #2 Phillips screwdriver and a cage nut tool are needed to install and secure the rails to the appliance.

Wear a set of leather work gloves when you are racking the appliance. They help to grip the appliance and to avoid injury from metal edges.

#### CAUTION:

**Do not use of any sort of hammer to secure the rails on the appliance. A hammer might damage the drives within the chassis and possibly void the warranty.**

#### Choose a setup location

Decide on a suitable location for the rack unit that holds your appliance.

*Table 3. Appliance location considerations*

Factor	Comments
Restricted access location	Install this appliance in a physically secure, limited access location only, such as a service closet or data center.
Clean environment	Situate it in a clean, well-ventilated, dust-free area.
Ambient operating temperature	If installed in a closed or multi-unit rack assembly, the ambient operating temperature of the rack environment might be greater than the ambient temperature of the room. Install the equipment in an environment compatible with the maximum rated ambient temperature (TMRA) for the appliance.
Sufficient airflow	Mount the equipment into a rack so that the amount of airflow that is needed for safe operation is not compromised. Leave enough clearance in front of the rack to open the front door completely (36 inches). Leave about 36 inches of clearance behind the rack for sufficient airflow and ease in servicing.
Mechanical loading	Mount the equipment into a rack so that a hazardous condition does not arise due to uneven mechanical loading. Install heavier items into the bottom of the equipment rack to keep the rack stable. Mount equipment in a rack evenly to prevent a later hazard.
Circuit overloading	Give consideration to the connection of the equipment to the power supply circuitry and the effect that any possible overloading of circuits might have on overcurrent protection and power supply wiring. Appropriate consideration of equipment nameplate ratings should be used when addressing this concern. <b>Note:</b> The maximum current draw is printed on a label on the appliance power supplies. The system might draw more than 15 Amps at startup (inrush current).
Reliable ground	A reliable ground must be maintained always. The rack itself must be grounded. Give particular attention to the power supply connections other than the direct connections to the branch circuit, such as the use of power strips.
Power supply	Use a regulating uninterruptible power supply (UPS) to protect the appliance from power surges and voltage spikes, and to keep your system operating in a power failure.

Table 3. Appliance location considerations (continued)

Factor	Comments
Heat, electricity, and EMI	Avoid areas where heat, electrical noise, and electromagnetic fields are generated.

## Prepare the rack

1. Ensure that the leveling jacks on the bottom of the rack are fully extended to the floor with the full weight of the rack on them.
  - In single rack installations, attach stabilizers to the rack.
  - In multiple rack installations, couple the racks together.
2. Check that the rack is stable before extending an appliance from the rack.
3. Extend only one appliance at a time. Extending two or more simultaneously can destabilize the rack.
4. Determine the placement of each appliance in the rack before you install the rails.
5. Install the heaviest appliances (usually the Slicestor<sup>®</sup> appliances) on the bottom of the rack first, and then work upward.

## Unpack and inspect the box and its contents

1. Inspect outside of box for damage.
2. Note if the box was damaged in any way.
3. Open the top of the box and inspect for damage.
4. Remove all of the components from the packaging and inspect for damage.
5. Arrange for assistance lifting or installing the appliance in a rack. Use a forklift or lift table to prevent possible injury.

### CAUTION:

**To prevent personal injury and equipment damage, have someone assist you during the equipment installation. If necessary, reduce the weight of the enclosure by removing the hard disk drives and power supply units during installation.**

**When using the lifting straps, keep them even and at the same level always. Otherwise, the system can slide to one side, and possibly out of the straps completely. Make sure that the rubberized sides of the lifting straps are against the chassis metal.**

6. If the appliance itself shows damage, file a damage claim with the carrier who delivered it.

In addition to the appliance, the box includes:

- Rail kits
- Cables
- Manual

## Remove packing materials on and in the appliance

1. Remove the tape warning on the top of the chassis that says: "Remove tape and foam before racking system."
2. Loosen the thumbscrews to either side of the faceplate for the appliance.
3. Open the faceplate.
4. Remove the packing foam from the inside of the faceplate.
5. Close the faceplate.
6. Tighten the thumbscrews.

---

## Appliance installation

**Attention:** Allow the enclosure assembly to acclimate to room temperature before installation. Store the disk drives at room temperature for at least 2 hours before use.

### Identify the sections of the rack rails

The box contains two rail kits. Each rail kit contains three sections, as shown in the following figure:

- The outer rail mounts to the front rack vertical post and rear rack vertical post.
- The middle rail allows the outer rail to extend or shorten to accommodate racks of different depths.
- The inner rail mounts on the side of the appliance and slides into the outer rail that is mounted on the rack, if wanted.

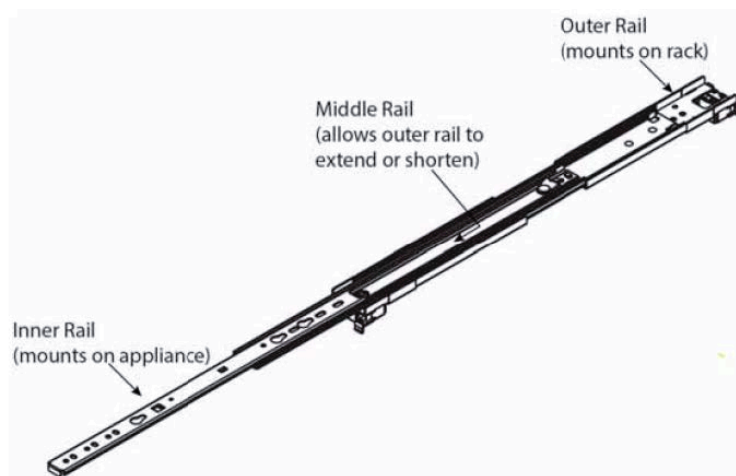

Figure 2. Identifying the sections of the rack rails

### Release the inner rail

Remove the inner rail from each rail kit, as shown in the following figure.

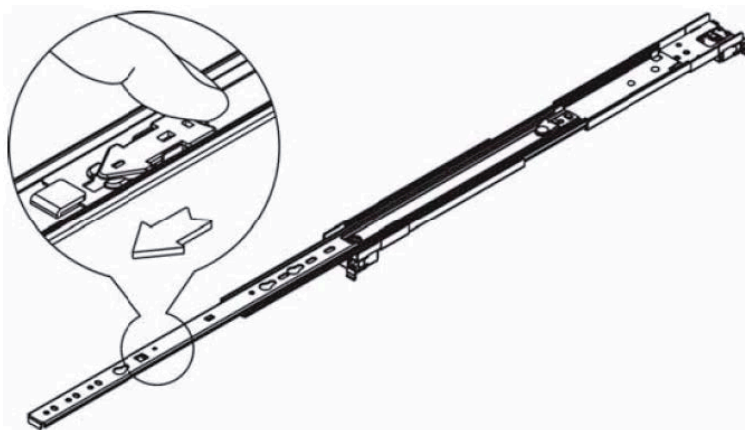

Figure 3. Remove the inner rails from both rail kits

1. Pull on the front release tab to unlock the inner rail from the rail kit.
2. Remove and set aside each inner rail.

## Retract the outer rail

After releasing and removing the inner rail, retract the outer rail to its shortest length, as shown in the following figure.

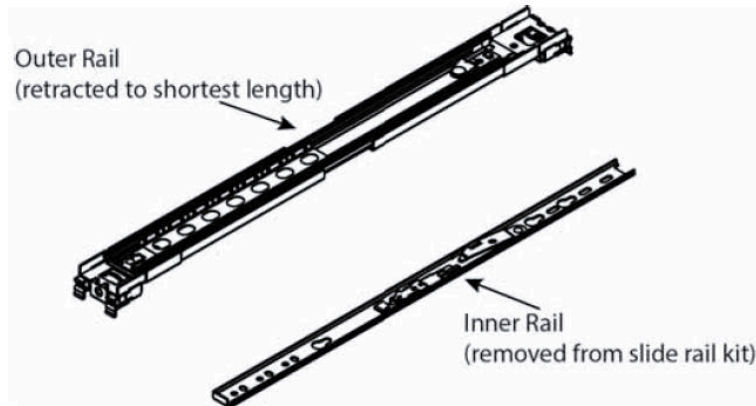

Figure 4. Retracting the outer rail

## Attach the inner rails to the appliance

1. Place the right inner rail on the right side of the appliance, making sure that the rail faces “outward” in the proper orientation so that it slides into the right outer rail.
2. Make sure that the inner rail screw holes and tabs are properly aligned with the matching screw holes and tab locators on the appliance.
3. Install the inner rail to the appliance by aligning the key holes on the rail with the studs on the side of the appliance.
4. Slide the inner rail towards the front of the appliance to hold it in place.
5. Secure the rail to the appliance with the screws that are provided in the rail kit, as shown in the following figure.

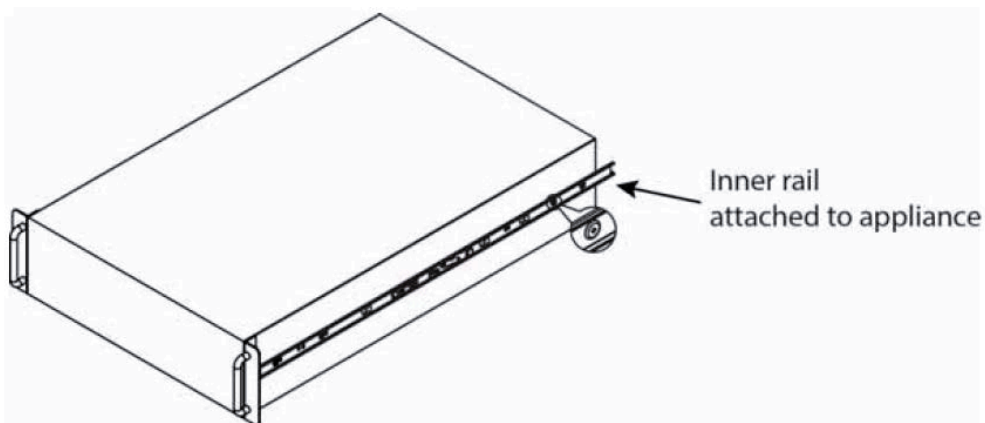

Figure 5. Attaching the sections of the rack inner rails

6. Repeat these steps for the left inner rail.

## Install the outer rails

1. Measure the distance from the front rail to the rear rail of the rack.
2. Extend the left outer rail so that it fits snugly into the allotted distance.



3. Adjust both the short and long brackets to the proper distance so that the rail can fit snugly into the rack.
4. Align the front tabs of the outer rail with the holes in the rack post, as shown in the following figure.

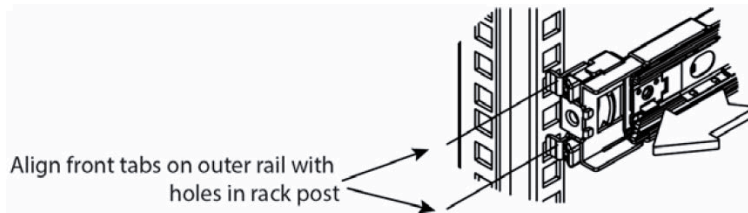

Figure 6. Aligning the outer rails with holes in rack post

5. Push the outer rail into the rack post so that the tabs go through the rack post and hold the rail in place, as shown in the following figure.

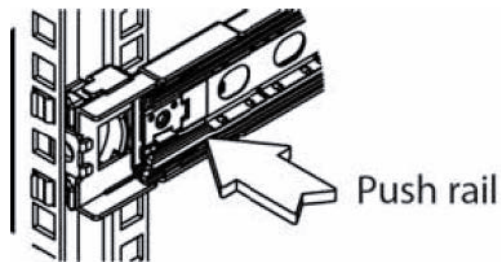

Figure 7. Push outer rail into rack post

6. Attach the back of the left outer rail to the rear rack post through a similar process, as shown in the following figure.

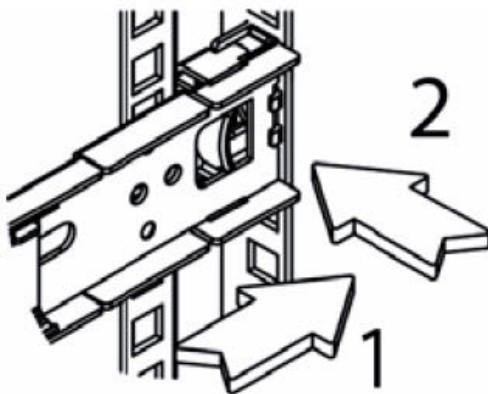

Figure 8. Attach back of outer rail

7. Repeat these steps for the right outer rail.

The final assembly of both outer rails is shown in the following figure.

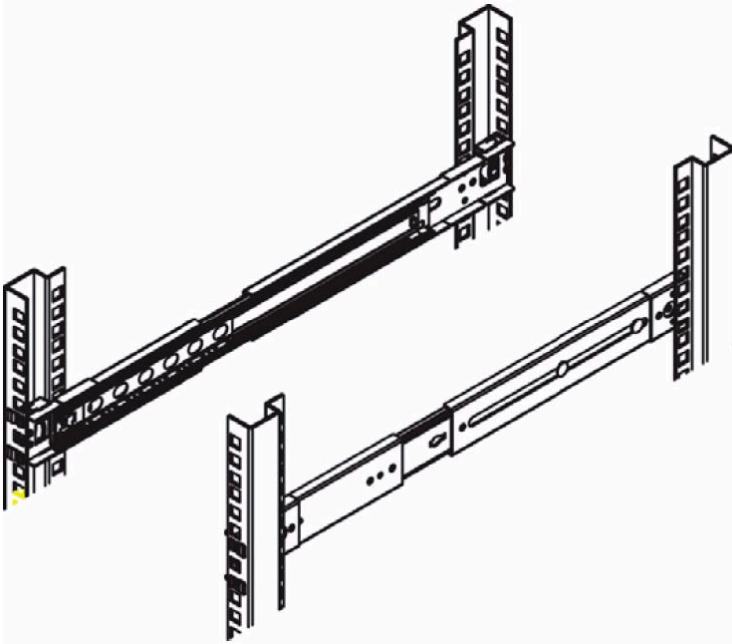

Figure 9. Final outer rail assembly and mounting

### Lock the rail tabs

Both chassis rails have a locking tab, which locks the appliance in place when:

- Installed and pushed fully into the rack.
- Extended fully from the rack so it does not come out of the rack when pulled out for service.

### Install the appliance into the rack

Attach the inner rails to the appliance chassis and the outer rails to the rack.

#### CAUTION:

**When you are ready to install the appliance in the rack, you might need a lifting device. Alternatively, use 2 - 4 individuals to place the appliance in position and begin inserting it into the rack rails.**

To install the appliance into the rack, do the following steps:

1. Line up the rear of the chassis rails with the front of the rack rails.
2. Slide the chassis rails into the rack rails, keeping the pressure even on both sides, as shown in the following figure. You might have to depress the locking tabs when inserting. When the appliance is pushed completely into the rack, you can hear the locking tabs click into the locked position.

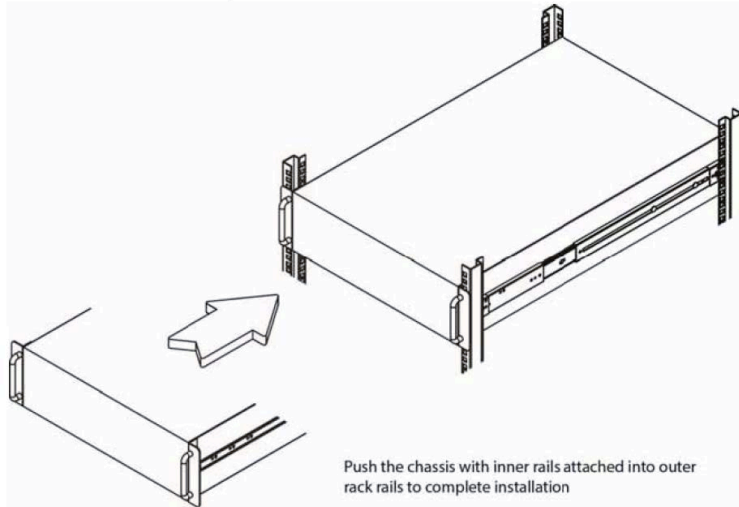

Figure 10. Push chassis into rack

- Secure the chassis to the rails with the captive M6 thumbscrews on the server.

### Cable the appliance

- On the rear panel, connect the C13 end of the power cables to the C14 inlets in the PSU, as shown in the following figure.

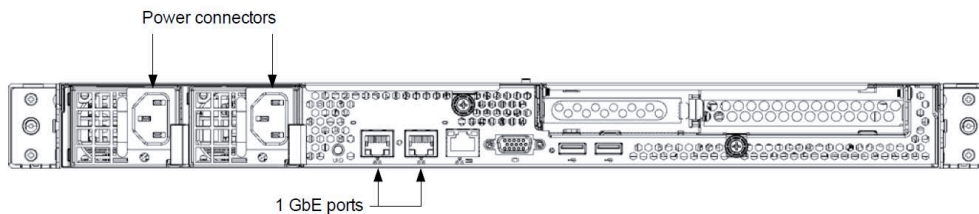

Figure 11. Rear of appliance

- The Ethernet connections are located just to the left of the center of the appliance and are next to each other. Connect a standard Ethernet cable from the left Ethernet port.
- Press the power button that is on the top far right corner of the appliance front panel when the bezel is unscrewed and flipped down.
- To ensure that the power is on, verify that the power and network link lights are lit and listen for running fans, as shown in the following figure.

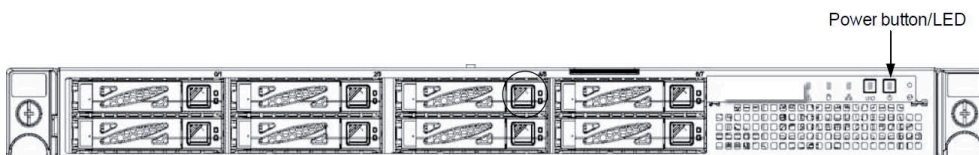

Figure 12. Front of appliance



## Chapter 4. Appliance physical interface

The physical interface for the appliance consists of buttons and LEDs on the front panel and ports and LEDs on the back panel.

### Front control panel

The power status and the hard disk drive and network activity of the appliance can be read from its front control panel, as shown in the following figure.

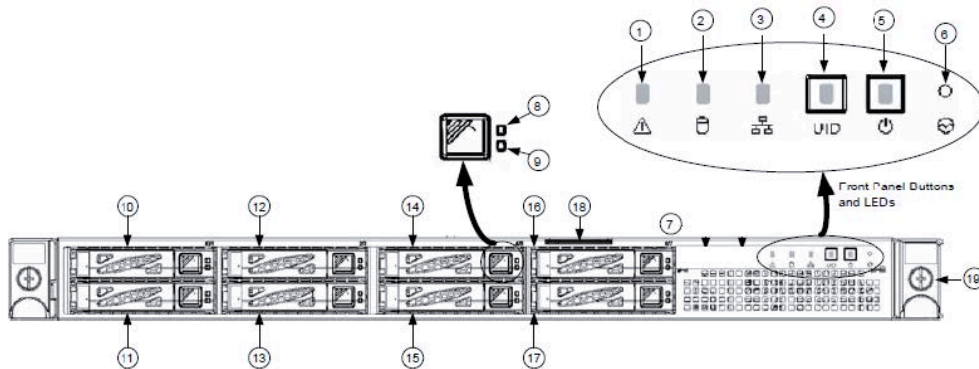

Figure 13. Front panel buttons and LEDs for the appliance

Table 4. Legend for front panel buttons and LEDs

Number	Description
1	System health LED
2	Disk activity LED
3	Network link activity LED
4	Unit identification button/LED
5	Power button/LED
6	Non-maskable interrupt (NMI) button
7	Unused
8	Individual disk activity LED (green)
9	Individual disk status LED (blue/amber)
10	Disk drive 0
11	Disk drive 1
12	Disk drive 2
13	Disk drive 3
14	Disk drive 4
15	Disk drive 5
16	Disk drive 6
17	Disk drive 7
18	Asset tag (a pullout mylar tag for customer use)

Table 4. Legend for front panel buttons and LEDs (continued)

Number	Description
19	Rack mount screw (2)

## Physical buttons

The appliance includes three push-buttons on the front panel:

**NMI** Issues a non-maskable interrupt to the server.

**UID** Facilitates finding a system in a rack that is viewed from the front. On the front panel, the LED is on the button. Similarly, a functioning UID button/LED is on the back panel.

**Power** Applies or removes power from the power supply to the appliance. Powering down the appliance removes the main power, but supplies stand-by power. The appliance must be unplugged before servicing.

## LEDs

The control panel has five LEDs to provide critical information for different components:

### Disk activity

One LED serves to indicate activity for any of the front-mount hard disk drives. When the green light is on or flashing, the hard disk is being accessed.

### Unit identification LED (UID)

This LED facilitates finding a system in a rack that is viewed from the front. On the front panel, the LED is on the button. Similarly, a functioning UID button/LED is on the back panel.

### Power LED

Power supplied to PSUs; should be lit to indicate that power is applied to the server.

### LAN active

When the green light is on, at least one of the LAN interfaces is active.

### System Health

When the light is green, the system is working correctly. When the light is amber, a problem is detected with system hardware. When the light is off, the disk drive is operational.

---

## Rear panel

The rear panel contains I/O ports.

### I/O ports

The I/O ports are color coded per the PC 99 specification. The locations of the various I/O ports are shown in the following figure.

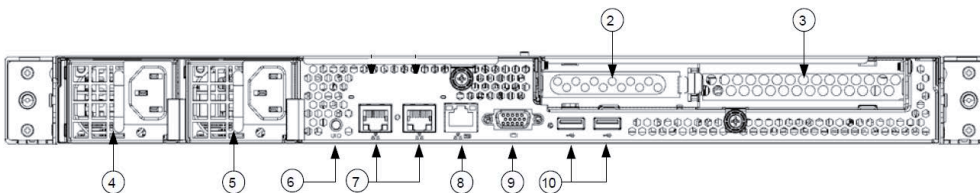

Figure 14. Rear panel I/O ports for the appliance

Table 5. Legend for rear panel I/O Ports for the appliance

Number	Description
1	Unused
2	PCIe card slot (on riser card)
3	10 GbE NIC card
4	Power supply 1
5	Power supply 2
6	UID button/LED
7	1 GbE RJ45 ports (2)
8	10/100 Mbit/s management port
9	DB-15 video connector
10	USB 2.0 ports (2)

## Network interface ports

### 1 Gbps LAN LEDs

The LAN ports have two LEDs. One LED indicates activity when blinking. The other LED can be green, amber or off to indicate the speed of the connection, as shown in the following figure. See the following table for the functions associated with the connection speed LED.

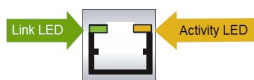

Figure 15. LAN LED connection speed indicator

Table 6. LAN LED connection speed colors

Color	Speed
Off	No connection or 10 Mbps
Green	100 Mbps
Amber	1 Gbps

### Intelligent Platform Management Interface (IPMI)

This network port allows remote administration of hardware. For a detailed description of IPMI, refer to the following Intel documentation:

<https://www.intel.com/content/www/us/en/servers/ipmi/ipmi-home.html>

### Power supplies

Each power supply includes one LED with three states in the rear.

Table 7. Power supply LED states

LED state	Description
Solid green	System on

Table 7. Power supply LED states (continued)

LED state	Description
Solid amber	System plugged in and turned off or the appliance is off but in an abnormal state
Blinking Amber	Internal temperature reached 63°C. The appliance automatically powers down when PSU temperature reaches 70°C and restarts when the PSU temperature drops below 60°C.

## Hard drive carrier

Each drive carrier has one LED with two states.

Table 8. Conditions indicated by drive carrier LEDs

Condition	LED color
Drive activity	Green
Drive failure	Red



---

## Chapter 5. Field replaceable units

A number of components can be replaced in the field.

---

### Replacement parts

Contact IBM Support for replacement parts for the appliance.

The following customer serviceable replacement parts are available:

- 4x8 GB Memory Modules
- Power Supply Module
- Operating System Drive

The following customer serviceable upgrades are available:

- SFP+/QSFP optical modules

See the *Field Replaceable Units Reference Guide* for a complete list of available parts and drives.

---

### Replace external front components

#### Check the status of the operating system/database drives

The operating system and database for the appliance are stored on a RAID-1 disk set. When one drive in this set is replaced, it rebuilds automatically. Check on the status of the RAID rebuild by using the Manager Web Interface:

1. Check the Device Health of the Manager from the **Monitor** page.
2. Click **Devices** from the list on the left side of the page.
3. Click **Manager**.
4. Click a specific Manager device.
5. Check the list of drives under **Summary of device health**.
  - If the drive was inserted correctly, the following message is displayed:  
**All drives are online.**
6. Check the Event Console for the status of the RAID repair.
  - If the drive in the RAID array is in repairing itself, the following message is displayed:  
**The local drive in bay *bay\_id* is repairing.**
  - If the drive in the RAID array is successfully repaired, the following message is displayed:  
**The local drive in bay *bay\_id* is repaired.**
  - If the drive in the RAID array is running correctly, this event shows:  
**Local drive array has been repaired.**

#### Replace the operating system/database drives

1. Press the release button on the drive carrier. This action extends the carrier handle, as shown in the following figure.

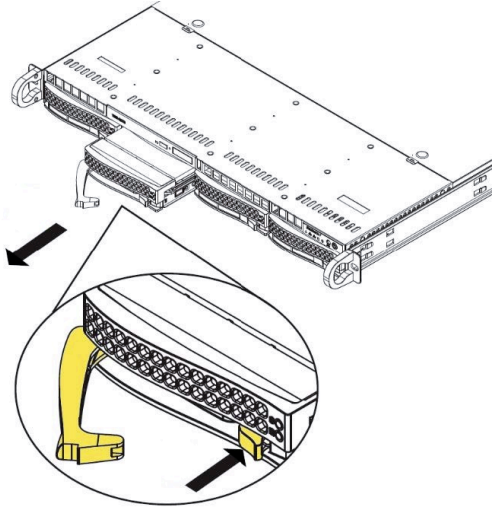

Figure 16. Removing a drive from the chassis

**Note:** The operating system drives are the two at the left. The preceding figure makes the extraction of the drive easier to see and is only for illustration purposes.

2. Pull the drive carrier out of the chassis by using the handle.
3. Insert the new OS drive into the open slot in the front of the appliance.
4. Contact IBM Support to issue OS drive recovery.

---

## Replace external rear components

### Replace a power supply unit

If either of the two power supply units (PSU) fails, the other unit takes the full load and the system can continue operation without interruption. The Universal Information LED on the control panel flashes slowly until the failed unit is replaced.

The PSUs can be replaced without powering down the appliance. The redundant feature keeps the appliance active while the failed PSU is replaced.

1. Push the release tab on the rear of the PSU, as shown in the following figure.

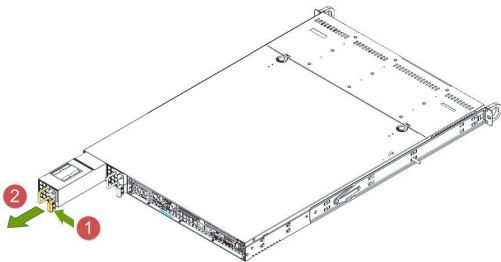

Figure 17. Removing a PSU from the chassis

2. Pull the PSU out using the provided handle. (The PSU wiring is designed to detach automatically when the PSU is pulled from the chassis).
3. Replace the failed PSU with another PSU.
4. Push the new PSU into the power bay until you hear a click.

## Install an SFP+ / QSFP optical module

1. Log in to the device as local admin.
2. At the command prompt, type poweroff.
3. Remove the SFP+ / QSFP module from the packaging.
4. Remove the black plastic protective cap from the optical side of the module.
5. Insert the module into the network card until it clicks into place.
6. Insert the fiber optic cable into the SFP+ / QSFP module.
7. Restart system and configure the network interface. For more information, see the *Appliance Configuration Guide*.

---

## Battery removal and installation

### Battery removal

To remove the Onboard battery, follow these steps:

1. Power off your system and unplug your power cable.
2. Locate the Onboard battery, as shown in the figure below.
3. Using a tool such as a pen or a small screwdriver, push the battery lock outwards to unlock it. When unlocked, the battery pops out from the holder.
4. Remove the battery, as shown in the following figure.

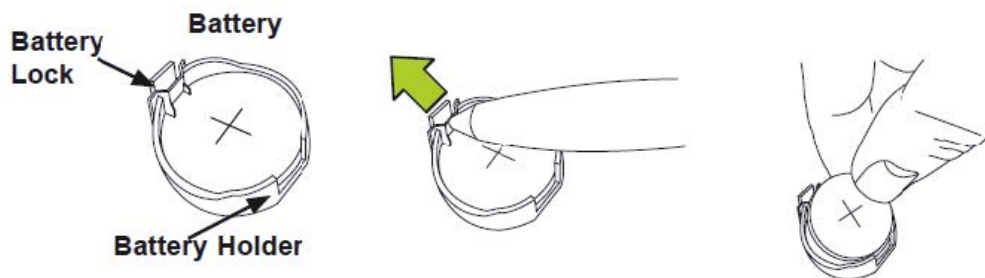

Figure 18. Remove the battery

### CAUTION:

Handle used batteries carefully. Do not damage the battery in any way; a damaged battery can release hazardous materials into the environment. Do not discard a used battery in the garbage or a public landfill. Refer to the IBM Systems Environmental Notices for battery disposal guidelines.

### Battery installation

To install an Onboard battery, follow these steps:

1. Identify the battery's polarity. The positive (+) side must be facing up.
2. Insert the battery into the battery holder. Push it down until you hear a click to ensure that the battery is securely locked, as shown in the following figure.



Figure 19. Install the battery

**CAUTION:**  
Be sure to replace the battery with the same type only.

---

## Notices

This information was developed for products and services offered in the US. This material might be available from IBM in other languages. However, you may be required to own a copy of the product or product version in that language in order to access it.

IBM may not offer the products, services, or features discussed in this document in other countries. Consult your local IBM representative for information on the products and services currently available in your area. Any reference to an IBM product, program, or service is not intended to state or imply that only that IBM product, program, or service may be used. Any functionally equivalent product, program, or service that does not infringe any IBM intellectual property right may be used instead. However, it is the user's responsibility to evaluate and verify the operation of any non-IBM product, program, or service.

IBM may have patents or pending patent applications covering subject matter described in this document. The furnishing of this document does not grant you any license to these patents. You can send license inquiries, in writing, to:

*IBM Director of Licensing  
IBM Corporation  
North Castle Drive  
Armonk, NY 10504-1785  
U.S.A.*

For license inquiries regarding double-byte character set (DBCS) information, contact the IBM Intellectual Property Department in your country or send inquiries, in writing, to:

*Intellectual Property Licensing  
Legal and Intellectual Property Law  
IBM Japan, Ltd.  
19-21, Nihonbashi-Hakozakicho, Chuo-ku  
Tokyo 103-8510, Japan*

INTERNATIONAL BUSINESS MACHINES CORPORATION PROVIDES THIS PUBLICATION "AS IS" WITHOUT WARRANTY OF ANY KIND, EITHER EXPRESS OR IMPLIED, INCLUDING, BUT NOT LIMITED TO, THE IMPLIED WARRANTIES OF NON-INFRINGEMENT, MERCHANTABILITY OR FITNESS FOR A PARTICULAR PURPOSE. Some jurisdictions do not allow disclaimer of express or implied warranties in certain transactions, therefore, this statement may not apply to you.

This information could include technical inaccuracies or typographical errors. Changes are periodically made to the information herein; these changes will be incorporated in new editions of the publication. IBM may make improvements and/or changes in the product(s) and/or the program(s) described in this publication at any time without notice.

Any references in this information to non-IBM websites are provided for convenience only and do not in any manner serve as an endorsement of those websites. The materials at those websites are not part of the materials for this IBM product and use of those websites is at your own risk.

IBM may use or distribute any of the information you provide in any way it believes appropriate without incurring any obligation to you.

Licensees of this program who wish to have information about it for the purpose of enabling: (i) the exchange of information between independently created programs and other programs (including this one) and (ii) the mutual use of the information which has been exchanged, should contact:

*IBM Director of Licensing  
IBM Corporation  
North Castle Drive, MD-NC119  
Armonk, NY 10504-1785  
US*

Such information may be available, subject to appropriate terms and conditions, including in some cases, payment of a fee.

The licensed program described in this document and all licensed material available for it are provided by IBM under terms of the IBM Customer Agreement, IBM International Program License Agreement or any equivalent agreement between us.

The performance data discussed herein is presented as derived under specific operating conditions. Actual results may vary.

Information concerning non-IBM products was obtained from the suppliers of those products, their published announcements or other publicly available sources. IBM has not tested those products and cannot confirm the accuracy of performance, compatibility or any other claims related to non-IBM products. Questions on the capabilities of non-IBM products should be addressed to the suppliers of those products.

Statements regarding IBM's future direction or intent are subject to change or withdrawal without notice, and represent goals and objectives only.

All IBM prices shown are IBM's suggested retail prices, are current and are subject to change without notice. Dealer prices may vary.

This information is for planning purposes only. The information herein is subject to change before the products described become available.

This information contains examples of data and reports used in daily business operations. To illustrate them as completely as possible, the examples include the names of individuals, companies, brands, and products. All of these names are fictitious and any similarity to the names and addresses used by an actual business enterprise is entirely coincidental.

#### COPYRIGHT LICENSE:

This information contains sample application programs in source language, which illustrate programming techniques on various operating platforms. You may copy, modify, and distribute these sample programs in any form without payment to IBM, for the purposes of developing, using, marketing or distributing application programs conforming to the application programming interface for the operating platform for which the sample programs are written. These examples have not been thoroughly tested under all conditions. IBM, therefore, cannot guarantee or imply reliability, serviceability, or function of these programs. The sample programs are provided "AS IS", without warranty of any kind. IBM shall not be liable for any damages arising out of your use of the sample programs.

If you are viewing this information softcopy, the photographs and color illustrations may not appear.

---

## Trademarks

IBM, the IBM logo, and [ibm.com](http://ibm.com)<sup>®</sup> are trademarks or registered trademarks of International Business Machines Corp., registered in many jurisdictions worldwide. Other product and service names might be trademarks of IBM or other companies. A current list of IBM trademarks is available on the web at Copyright and trademark information at [www.ibm.com/legal/copytrade.shtml](http://www.ibm.com/legal/copytrade.shtml).

Accesser<sup>®</sup>, Cleversafe<sup>®</sup>, ClevOS<sup>™</sup>, Dispersed Storage<sup>®</sup>, dsNet<sup>®</sup>, IBM Cloud Object Storage Accesser<sup>®</sup>, IBM Cloud Object Storage Dedicated<sup>™</sup>, IBM Cloud Object Storage Insight<sup>™</sup>, IBM Cloud Object Storage Manager<sup>™</sup>, IBM Cloud Object Storage Slicestor<sup>®</sup>, IBM Cloud Object Storage Standard<sup>™</sup>, IBM Cloud Object Storage System<sup>™</sup>, IBM Cloud Object Storage Vault<sup>™</sup>, SecureSlice<sup>™</sup>, and Slicestor<sup>®</sup> are trademarks or registered trademarks of Cleversafe, an IBM Company and/or International Business Machines Corp.

Other product and service names might be trademarks of IBM or other companies.

---

## Homologation statement

This product may not be certified in your country for connection by any means whatsoever to interfaces of public telecommunications networks. Further certification may be required by law prior to making any such connection. Contact an IBM representative or reseller for any questions.









Printed in USA